

ValuLine® Softwall Modular Cleanroom

© Copyright 2026 Terra Universal Inc. All rights reserved - Revised Feb. 2026



Your Comprehensive
 Equipment Source





Table of Contents

Proprietary Notice 2

Section 1.0 – Description

Description 3

Frame 3

Fan Filter Units 4

Light Panels 5

Blank Ceiling Panels 5

Softwall Panels & Strip Shields 5

Casters 6

Section 2.0 –Installation

Site Preparation 6

Required Installation Equipment 6

Components List 7

Cleanroom Frame Components 8

Ceiling Components 8

Support Bar Components 9

Curtain Panel Components 9

Frame Assembly 10

Seismic Anchoring 12

Joists and Divider Installation 13

Use of the Spacer 16

Support Bar Installation 17

Installing the Ceiling Modules 18

Curtain Panel Installation 19

Fire Sprinkler System Installation 23

Fire Sprinkler System 23

Section 3.0 – Electrical Wiring

Installing the Power Supply Unit (PSU) 24

Fan Filter Unit Hard Wiring 25

Section 4.0 – Operation & Maintenance

Filter Replacement 26

Cleanroom Maintenance 29

Section 5.0 – Warranty

Warranty Information 30

Section 6.0 – Spare Parts & Accessories

Spare Parts & Accessories 31



Proprietary Notice

This manual pertains to proprietary devices manufactured by Terra Universal, Inc. Neither this document nor any portion of it may be reproduced in any way without prior written permission from Terra Universal.

Terra Universal makes no warranties applying to information contained in this manual or its suitability for any implied or inferred purpose. Terra Universal shall not be held liable for any errors this manual contains or for any damages that result from its use.

Safety Notice

A thorough familiarity with all operating guidelines is essential to safe operation of the product. Failure to observe safety precautions could result in poor performance, damage to the system or other property, or serious bodily injury or death.



Cautions are used when failure to observe instructions could result in significant damage to equipment.

The following symbols are intended to call your attention to two levels of hazard involved in operation:



Warnings are used when failure to observe instructions or precautions could result in injury or death.

The information presented here is subject to change without notice.

	<p>IMPORTANT SAFETY NOTICE</p> <p>Terra Universal cleanrooms are not designed to support more weight than the blower modules and lighting fixtures originally installed. Ceiling grid beams are not load-bearing and will not support personnel or other additional loads. Placing added weight on the ceiling grid may result in serious damage to the cleanroom and its occupants.</p> <p>Safety notices supplied by Terra Universal must be affixed prominently on each side of the cleanroom grid.</p>
--	---

1.0 Description

Terra Universal's Softwall Modular Cleanrooms provide an economical, versatile solution to clean manufacturing requirements in many industries. Portable, expandable, and easy to assemble/disassemble, this system features ceiling HEPA fan filter units that direct a continuous flow of particle-free air through the enclosure. It is completely free standing and requires no external bracing.



Frame

This system consists of a steel support frame, ceiling mounted filtration and illumination system, flexible side panels and a variety of other access options.

The softwall cleanroom support frame is fabricated of interlocking 2.5" powder-coated square steel or stainless steel uprights, cross sections, and ceiling members.

Ceiling members are connected to steel T-bars, forming the 2' X 4' bays that support filters and lights. Corner reinforcement gussets ensure a rigid structure. Optional heavy-duty casters allow easy repositioning after installation. Standard height is seven feet measured from filter face to floor (8' 3" overall), allowing installation below a standard nine foot ceiling. Custom ceiling heights up to ten feet are available. System includes a control panel for operation of fan filter units, lights, and other selected options.



Fan Filter Units (FFUs)

FFUs direct a vertical laminar flow of filtered air downward through the enclosed cleanroom area.

Each includes a built-in motor and impeller, mounted in an aluminum housing with a plenum design that ensures ample air velocity across the entire face of the filter. A HEPA (high efficiency particulate air) filter installed inside the housing is rated 99.99% efficient at 0.3um particles. The filtration medium consists of micro porous polyurethane mini-pleats held in place by strong, rigid plastic separators that keep the medium from nesting. This design channels airflow with optimal efficiency to reduce resistance. The filter is sealed into the sturdy powder-coated steel frame with a fire-retardant, non-outgassing adhesive. On an optional basis, an ULPA (ultra-low penetration air) filter, rated 99.9995% efficient at 0.12um particles, may be substituted for the HEPA filter. Power to the Fan Filter Units is controlled by a master ON/OFF switch located on the cleanroom control panel. All 120VAC units and 220VAC, 60Hz units are UL listed. CE-marked models are available for 220VAC, 50Hz operations.



Filter Fan Units (HP: high speed; MS: medium speed; LS: low speed)											
Model	Dimensions Inches (mm)	Wt. Lbs. (Kg)	Avg. CFM @ MS	Airflow ft/min (m/s)			Run Amps Watts @ 60Hz			Power	
				HS	MS	LS	HS	MS	LS		
2 x 4	23.63 x 47.63 x 12.51 (600 x 1210 x 318)	71	717 (1218)	115 (.58)	102 (.51)	93 (.47)	4.3A (512W)	3.5A (416W)	3.3A (393W)	120VAC, 60 Hz 220VAC, 50/60 Hz	
2 x 3	23.63 x 35.63 x 12.51 (600 x 905 x 318)	53	602 (1023)	121 (.61)	116 (.59)	106 (.54)	4.1A (500W)	3.1A (378W)	2.7A (329W)	120VAC, 60 Hz 220VAC, 50/60 Hz	
2 x 2	23.63 x 23.63 x 12.51 (600 x 600 x 318)	44	558 (948)	172 (.87)	166 (.84)	162 (.82)	3.9W (472W)	2.8A (339W)	2.4A (290W)	120VAC, 60 Hz 220VAC, 50/60 Hz	

Recommended Qty of FFUs to meet Cleanliness Classifications (based on ceiling height of 8 feet or less):

Nominal Dimensions	No. of Ceiling Bays	No. of Filter Modules to meet Fed Std 209 Class Standards					
		1	10	100	1,000	10,000	100,000
8' x 8'	8	5-8	4-8	3-6	2-3	1-2	1
8' x 12'	12	7-12	6-12	4-8	3-5	2-3	1-2
8' x 16'	16	10-16	8-16	6-11	4-6	2-4	1-3
12' x 12'	18	11-18	9-18	6-13	5-7	3-5	1-3
12' x 16'	24	14-24	12-24	8-17	6-10	4-6	2-4
16' x 16'	32	19-32	16-32	11-22	8-13	5-8	2-5
20' x 20'	50	30-50	25-50	18-35	13-20	8-13	3-8

UL Label: If your order included UL documentation (Cat. # 6600-33), your cleanroom will include labels indicating the use of UL-listed components on one of the triangular gussets (see below photo).





Light Panels



Each light panel is externally mounted to ensure effective illumination of the work area without interfering with the controlled air stream. Each module is controlled by a master switch mounted on the main Cleanroom Control Panel.

Cat. # 3800-41B

Power Requirements

USA: 115VAC/60Hz, 1.50A Each

International: 277VAC/50Hz, 0.65A Each

Blank Ceiling Panels

All remaining ceiling grids are covered with blank panels, which can be removed to allow installation of additional fan filter units or illuminator modules. Panels are made of white polypropylene, acrylic or steel depending on customer selection. All ceiling modules rest against the ceiling grid frame to form a tight seal along the perimeters.

Softwall Panels & Strip Shields

Softwall panels are fabricated of heavy-duty, blur-free 40 mil, vinyl or polyurethane—double the industry standard—ensuring enhanced tear resistance and eliminating the need for unsightly sewn sash weights. Strip shields, made of 60-mil material, come standard in 8” widths, with 2” overlap, for easy entrance or exiting. Polyurethane shields are 12” W, 40 mil thick.

Panels and strips are available in three materials, in either clear or frosted appearance.

- Cleanroom-Grade Vinyl is fire retardant and low outgassing
- Static-Dissipative Vinyl is manufactured with permanent built in static inhibitors that unlike topical treatments, will not wear off.
- Non-outgassing panels are made from inherently static-dissipative polyurethane that provides permanent, humidity-independent ESD protection for sensitive manufacturing conditions. Polyurethane contains no plasticizer, making it virtually non-outgassing.



Note: Softwall panels are notched to ensure a snug fit at all corners. In standard installations, panels are supplied in lengths of four feet. Where two panels meet, the panels overlap by 6”. To prevent personnel from parting panels at these seams, order optional panel seaming, Dual-Lock Velcro, magnetic closures or attachment clips below.

Panel Options	Cat. #
Dual – Lock Velcro Strips	6704-05
Flexible Magnet Strip Self-Closures	6704-06
Snap – Tite™ Clips	6704-07
Curtain Seaming	6600-65



Casters



Stainless steel swivel casters feature non-shedding polyurethane wheels. Capacity: 300 lbs. each. Order one per vertical post. Casters raise the frame 7.125". If casters are ordered, the frame will be made shorter to keep the floor to filter face dimension to specification. Order one per vertical post.
Cat. # 6704-08



Caution: Casters are intended to allow movement only on smooth floors and require that personnel support each cleanroom upright during motion.

2.0 Installation

Unpack all system components and check for damaged. Any damage should be reported to the shipping company immediately.

Site Preparation

- A. Site preparation requirements should be observed for any installation performed by Terra Universal technicians.
- B. Customer facility area where the cleanroom is to be installed must afford a minimum clearance of one foot (including fixtures ducts and pipes) on all sides and at least two feet clearance between FFU inlet and ceiling.
- C. Customers must provide permanent electrical connection from supply panel to Terra Cleanroom electrical junction boxes (one power line per junction box) in conformance with local electrical code, as well as any vacuum, air, H2O, sprinkler, or nitrogen connections required for the cleanroom.
- D. Customers must give advance notice of dates and times for Terra personnel to perform the installation. Short notice may result in higher fees for travel and accommodations.
- E. Customers are to provide utilities, installation power and removal of any packing material.
- F. Because installation requires unpacking and assembling components, customers are to ensure an adequate staging area for parts and equipment adjacent to the assembly area, clear and ready for work.
- G. Customers are to inform Terra Universal in advance of any requirements for security, escorts, special training, badges, work hours, parking areas or special identification and how to obtain all such required permissions and related items.

Required Installation Equipment

- A. Handling cleanroom shipping crates, which generally measure over 300" long and weigh well over 1,000 pounds, requires at least one forklift. If crates must be moved through narrow aisles or entrances, two forklifts or pallet jacks are recommended, one to support each end.
- B. Unloading crates from the truck is much easier if you have a truck-high loading dock. Without such a dock, you will need at least one forklift and a support to brace one end while the forklift is positioned beneath the center of each crate. Several men are required to unload individual components from the crates.
- C. You'll need heavy rubber hammers, good portable drills/screwdrivers, measure tapes (to make sure everything's square) and six to ten 11" locking C-Clamps used to hold beams in place as you insert fasteners. Another tool that will be needed is an 8" – 12" shaft extension for the screwdriver bits (to drive screws in narrow gaps between parts).







Components List

The list includes the basic cleanroom components. Quantities vary based on the specifications of each particular unit.

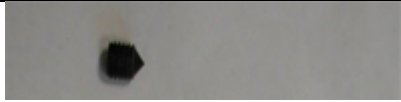
Electrical Service Equipment:

- Power Supply Unit to turn on fan filter units and light panels.
- Power Strip (can hook up to 6 lights and 6 fan filter units modules)
- 115 or 230 VAC yellow power cables (normally connected to FFUs and lights before shipping).
- 4-Pin Adapter Cable (to connect the fan filter unit to the power strip)
- 3-Pin Adapter Cable (to connect the light panel to the power strip)

PICTURE	USED FOR	DESCRIPTION
	Frame	Black 3/8" X 1/2" Allen Screw Socket Set Cone Point
	Support Bar & Joists	Screw SS # 12 X 3/4" Self-Tapping Sheet Metal Screw
	Fasten Ceiling Panels (1- Sided)	Clip 1-Arm Ceiling (Optional, if requested)
	Fasten Ceiling Panels (2- Sided)	Clip 2-Arm Ceiling (Optional, if requested)



Cleanroom Frame Components

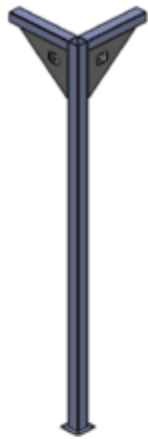

CORNER POST



CENTER POST



CORNER POWER POST

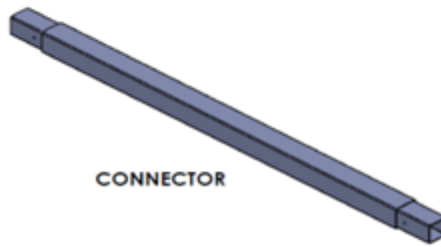

CONNECTOR

Ceiling Components

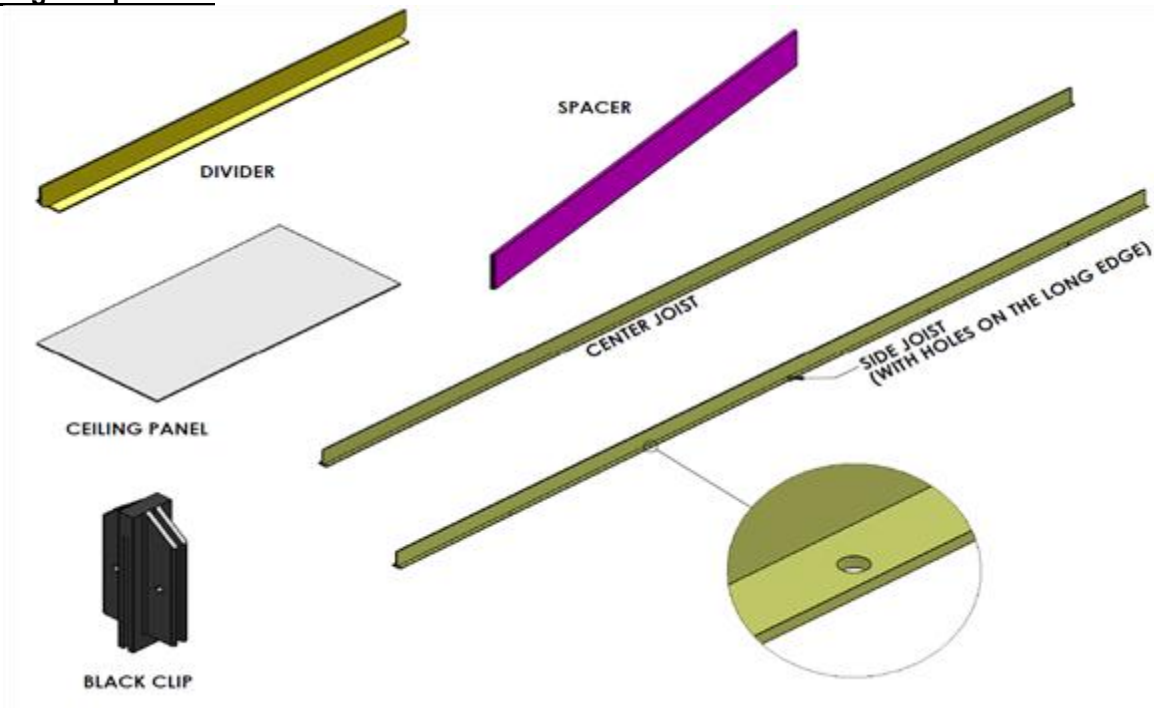



Support Bar Components

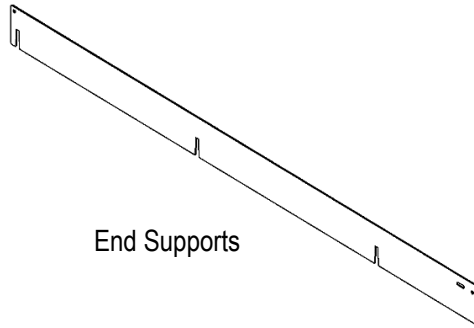
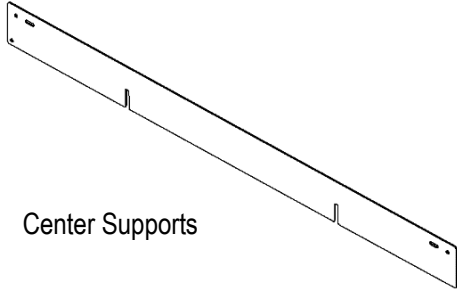

Top Trimming Components

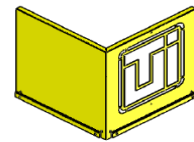
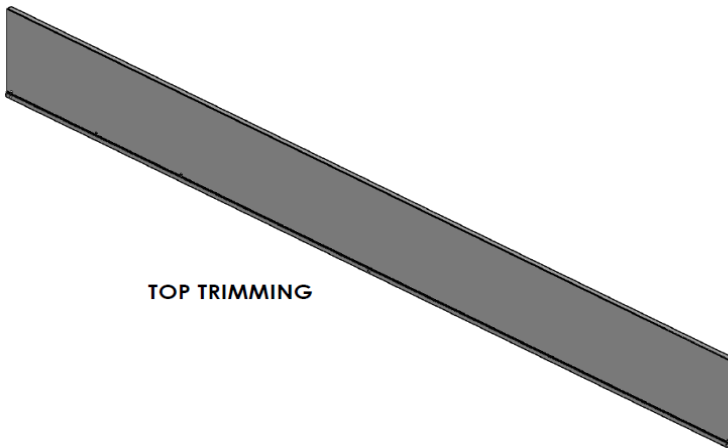



Curtain Panel Components

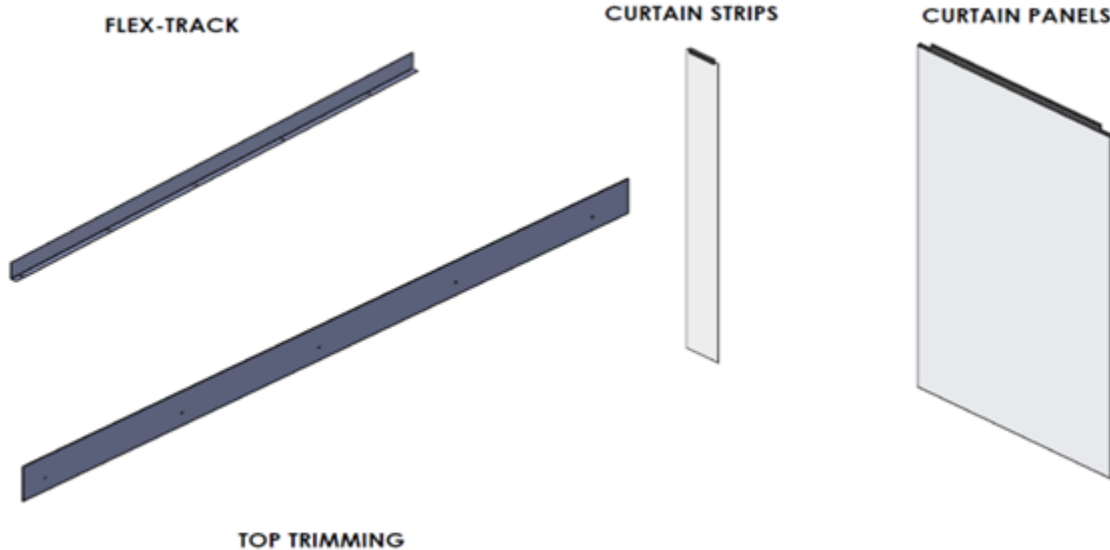

Frame Assembly

Installation Note: Before beginning installation of the support frame, familiarize yourself with the placement of the frame members.



IMPORTANT SAFETY NOTICE

Terra Universal Cleanrooms are not designed to support more weight than the blower modules and lighting fixtures originally installed. In particular, the ceiling grid beams are not load bearing and will not support personnel or other additional loads. Placing added weight on the ceiling grid may result in serious damage to the cleanroom and its occupants.

Safety notices supplied by Terra Universal must be affixed at appropriate places on each side of the cleanroom grid.

Prior to shipping, all frame and ceiling members are stamped and then labeled at each end. Refer to the appendix for detailed information on how your cleanroom is numbered.

Before you start assembly, it is mandatory that the floor is level to assure the completed room will fit properly and be rectangular. Failure to level the floor may result in the inability to complete the assembly of the room or the insertion of the blowers, lights or ceiling. For vertical alignment, measure with the leveler before assembly.



STEP 1: MAKE SURE THE FLOOR IS LEVEL FIRST

STEP 2: REFER TO THE DRAWING TO SEE HOW EACH COMPONENT COMES TOGETHER STARTING AT A CORNER FRAME

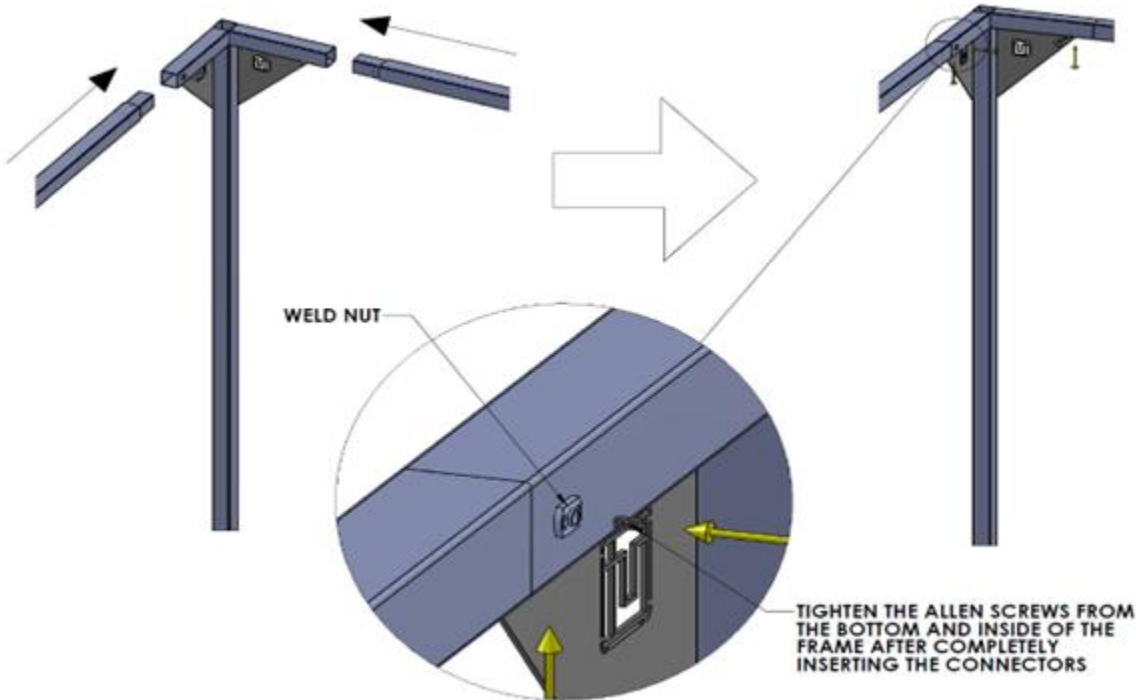

STEP 3

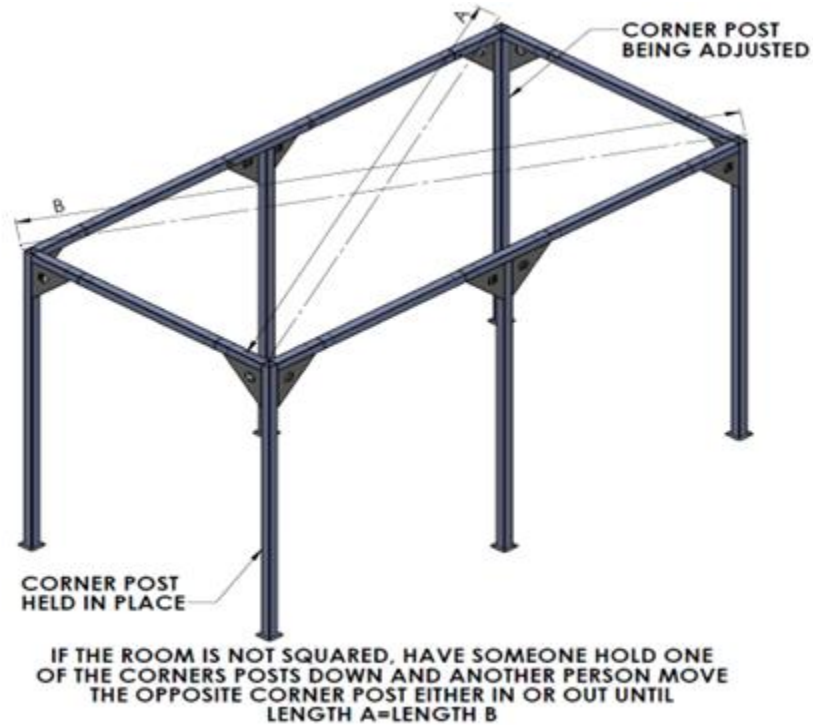

STEP 4

Verify that the overall dimensions match the drawing.

Seismic Anchoring

Because most Softwall Cleanroom models have custom configurations, the number of screws required for seismic anchoring will vary based on the size of the cleanroom. Each post on the frame has a foot with four pre-drilled holes. Be sure to adhere to local seismic codes when anchoring the cleanroom. Terra recommends drilling 6" deep and placing a 3/8" Kwik Bolt TZ (not included) anchor for a minimum embedment of 3-5/8" in each of the foot's holes. This is an example, but local seismic codes may vary.



EXAMPLE DIAGRAM

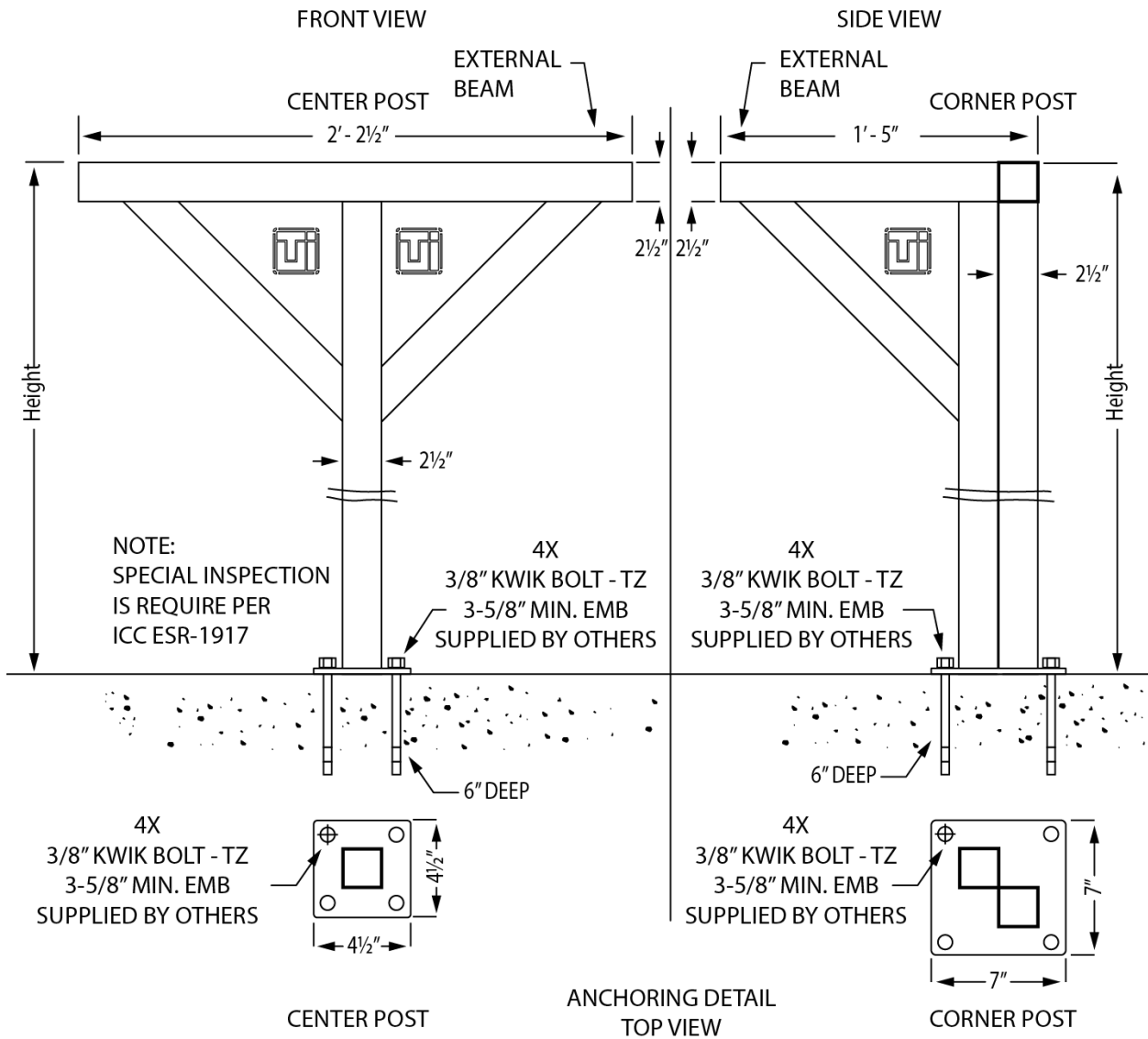



Joist and Divider Installation

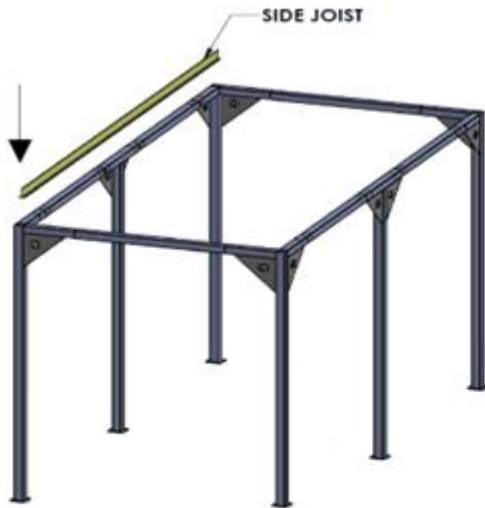

JOISTS ARE BOWED TO COMPENSATE FOR THE WEIGHT OF ALL THE FFUS, LIGHTS, PDMS, AND OTHER CEILING ACCESSORIES

NOTE: ONLY SIDE JOISTS HAVE EXTRA FASTENING HOLES

STEP 1

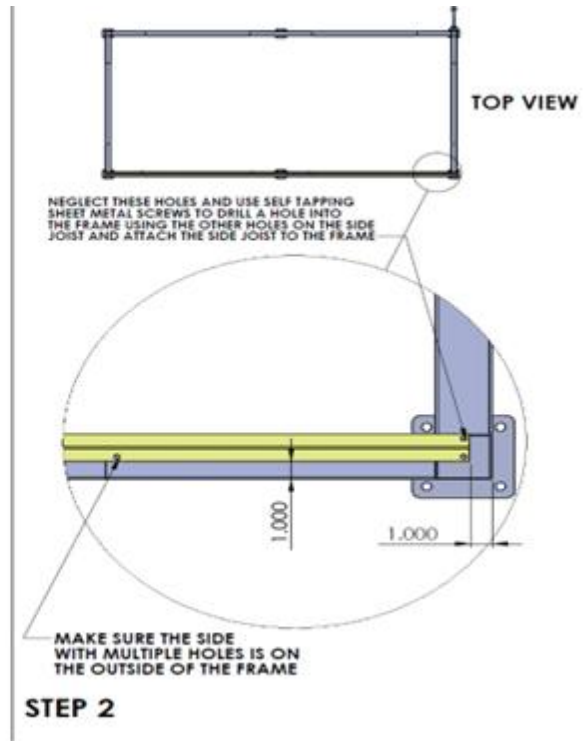

NEGLECT THESE HOLES AND USE SELF TAPPING SHEET METAL SCREWS TO DRILL A HOLE INTO THE FRAME USING THE OTHER HOLES ON THE SIDE JOIST AND ATTACH THE SIDE JOIST TO THE FRAME

MAKE SURE THE SIDE WITH MULTIPLE HOLES IS ON THE OUTSIDE OF THE FRAME

STEP 2

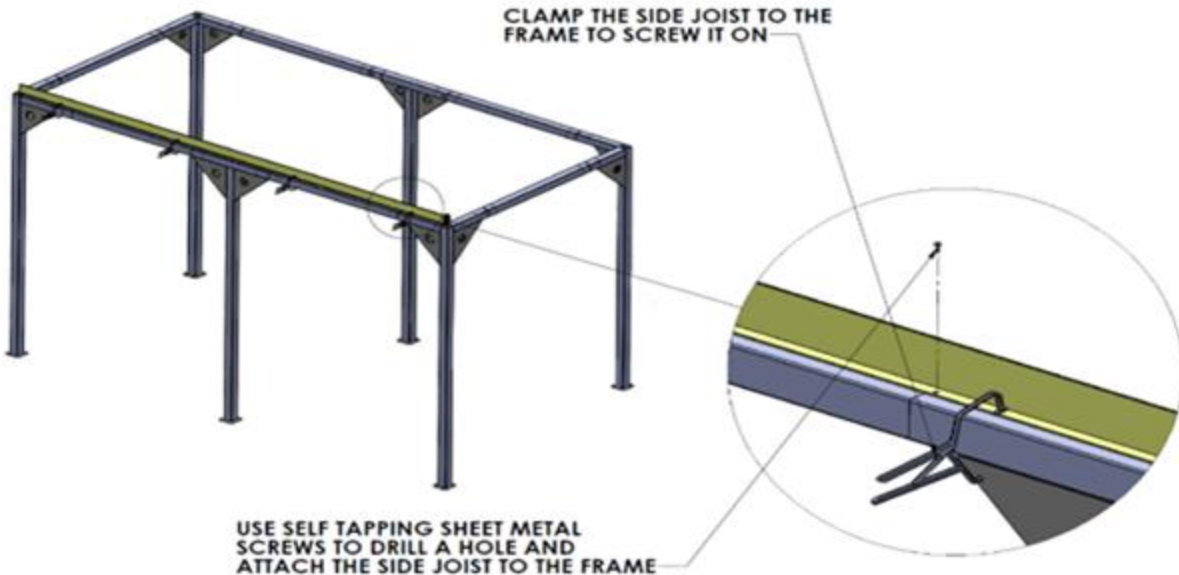

CLAMP THE SIDE JOIST TO THE FRAME TO SCREW IT ON

USE SELF TAPPING SHEET METAL SCREWS TO DRILL A HOLE AND ATTACH THE SIDE JOIST TO THE FRAME

REMOVE THE CLAMPS AFTER SCREWING THE SIDE JOIST TO THE FRAME

STEP 3

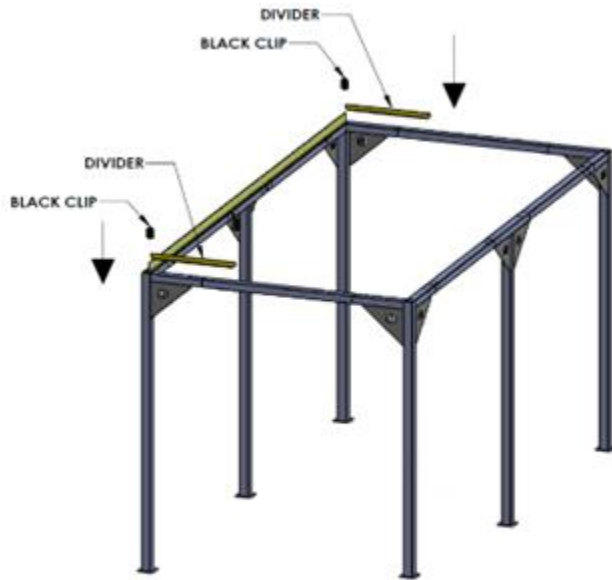

STEP 4

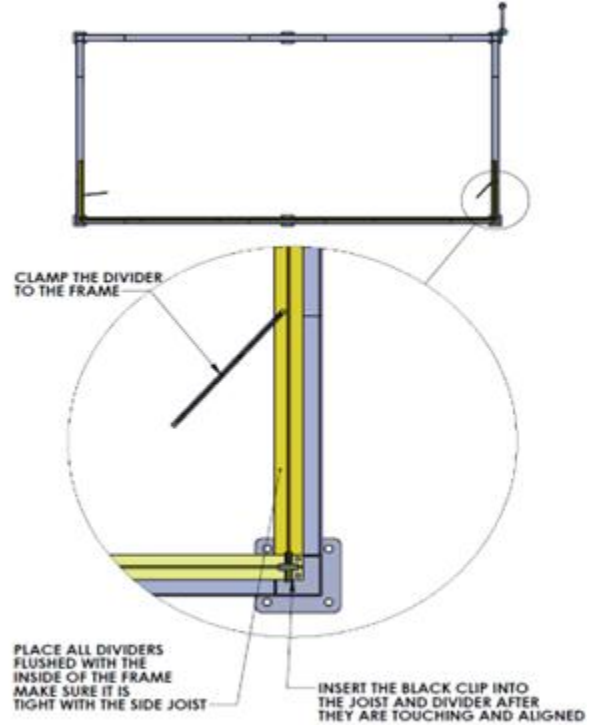

STEP 5

NOTE: CENTER JOISTS DO NOT HAVE HOLES ALONG THE LONG EDGE

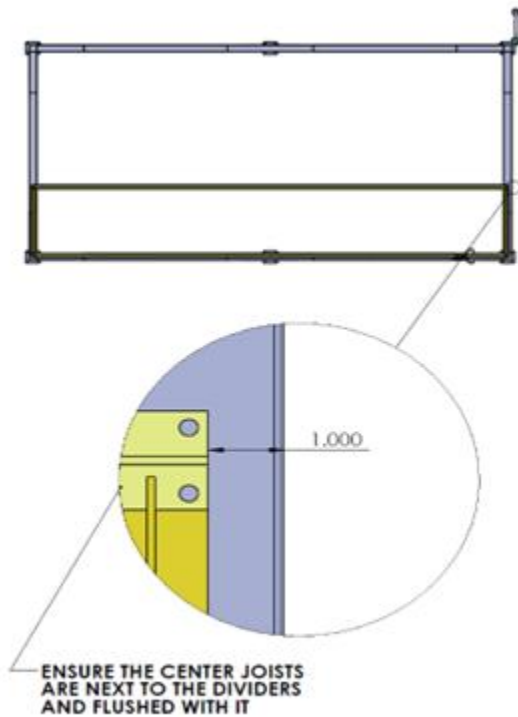

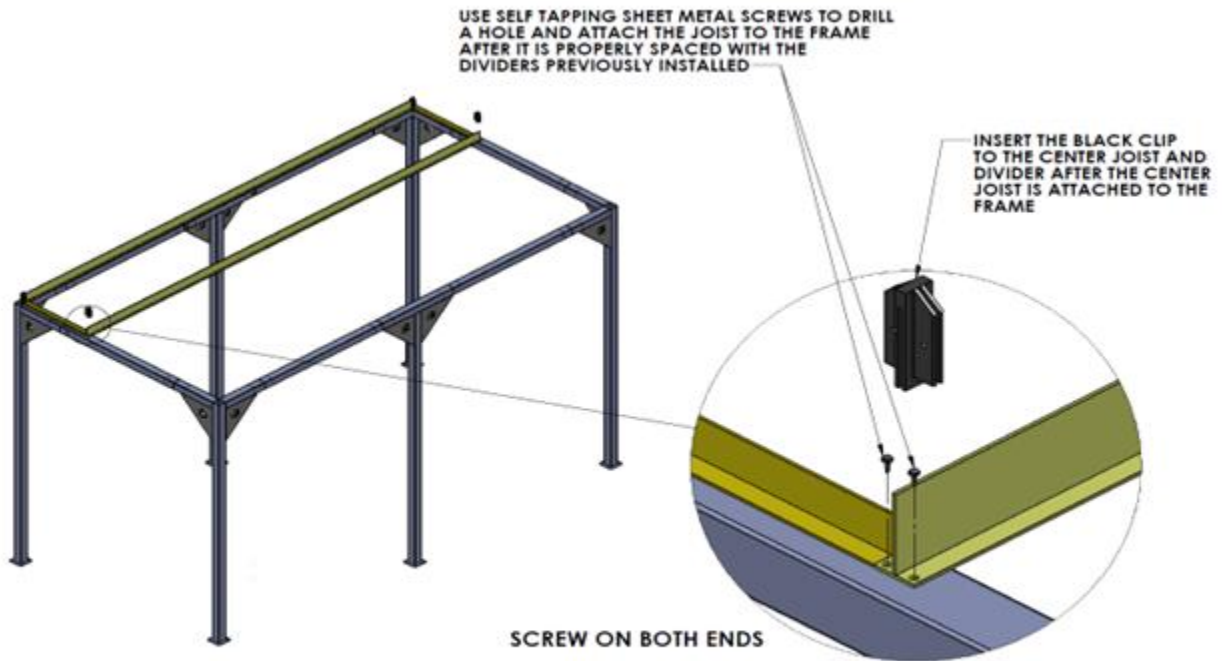

STEP 6



REPEAT STEPS 4-6 TO COMPLETE THE INSTALLATION OF THE CENTER JOISTS AND OUTER DIVIDERS



Use of the Spacer

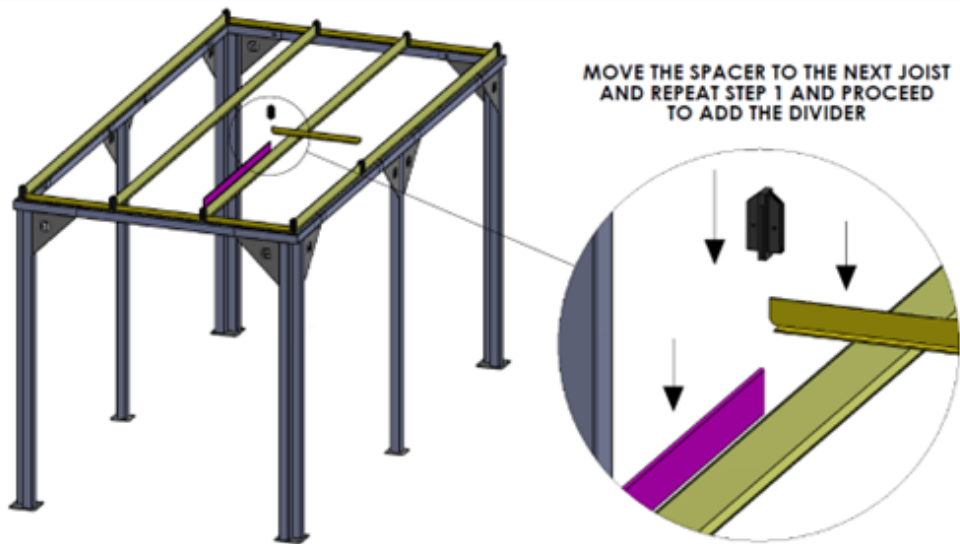
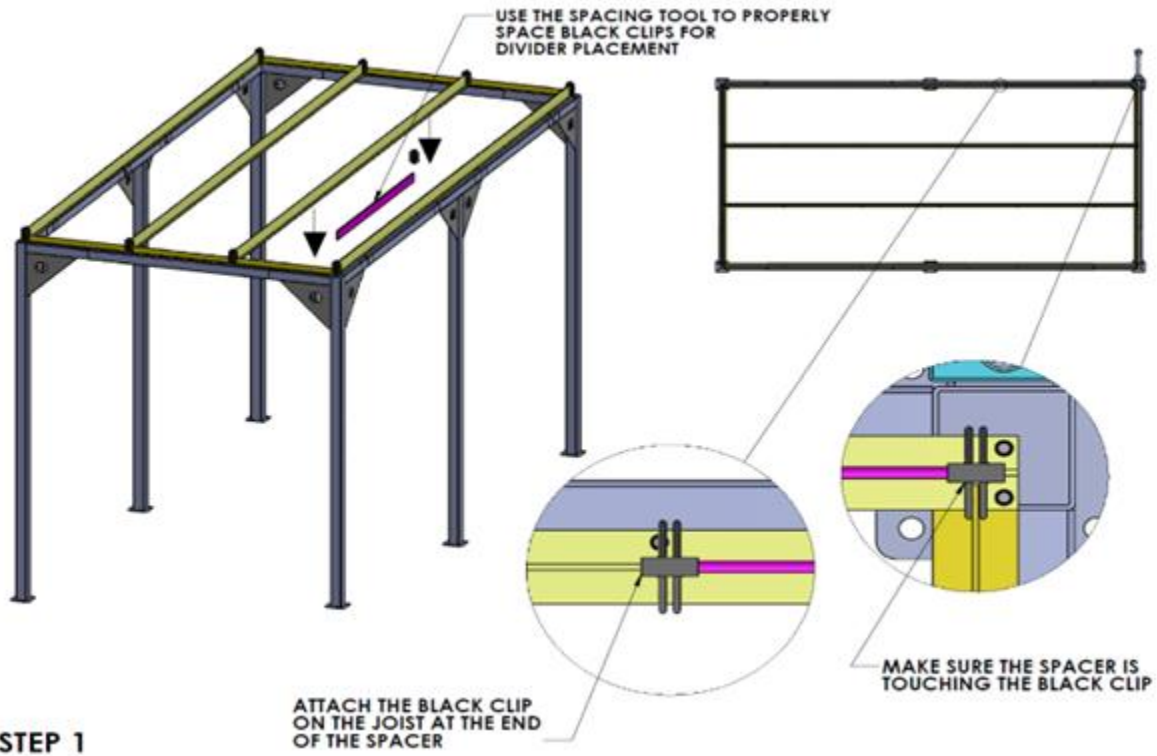

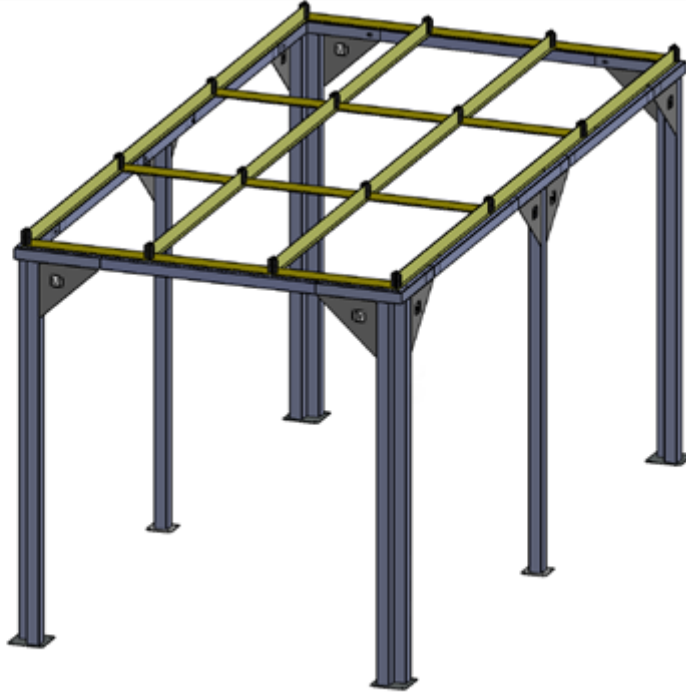

STEP 3

REPEAT STEPS 1-2 UNTIL THE CEILING GRID IS COMPLETE

Recheck the frame to ensure that the structure is square.

Support Bar Installation

The flat support bars with the notches will fit over the black clips and space the joist evenly. The overlap will be wedged into each other via bolt and nut.

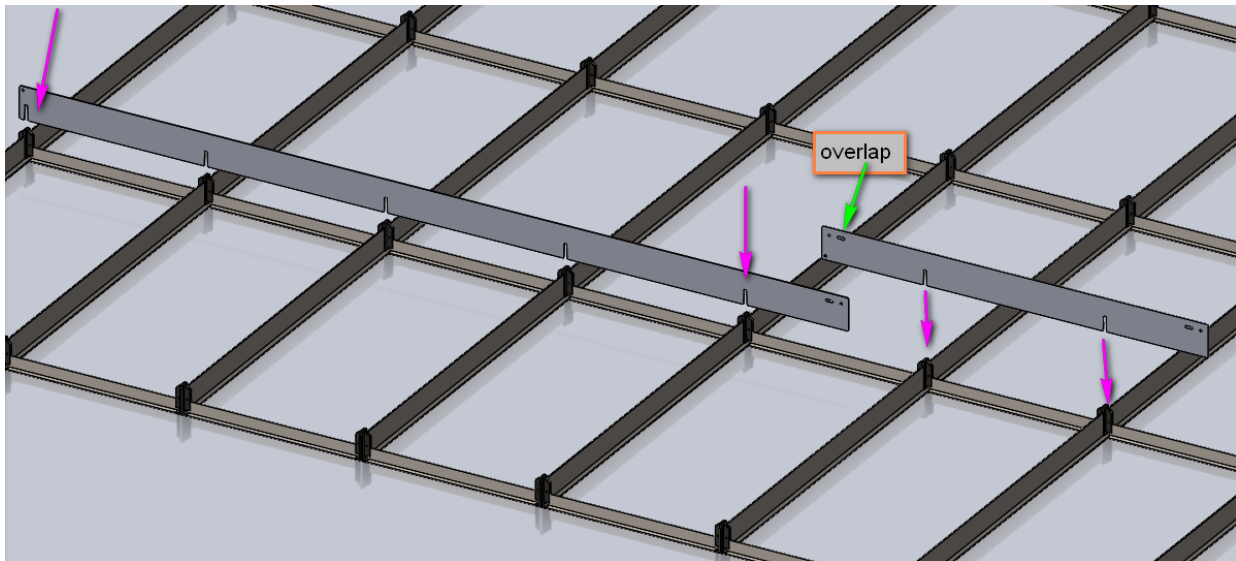



Top Trimming Installation

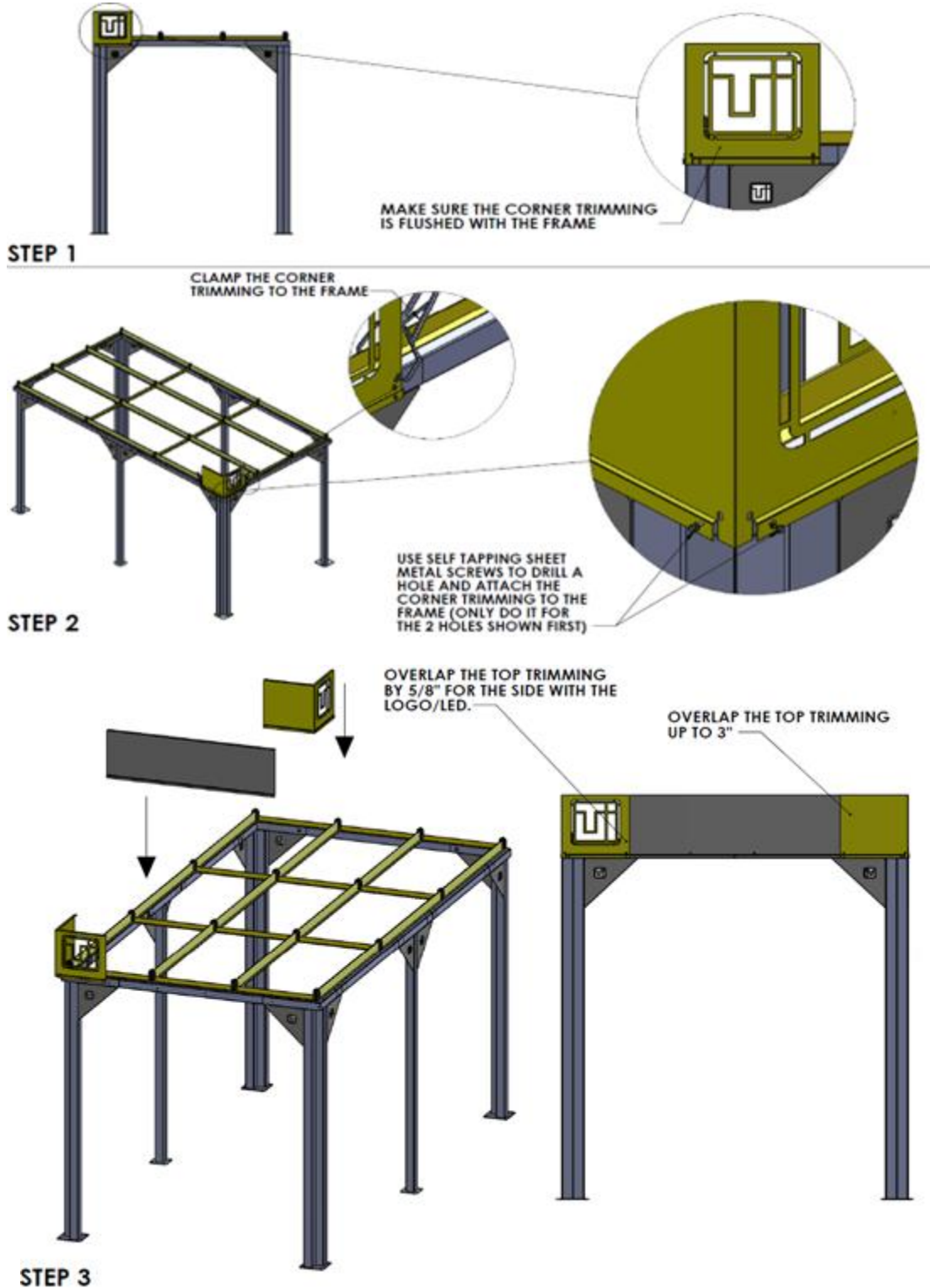

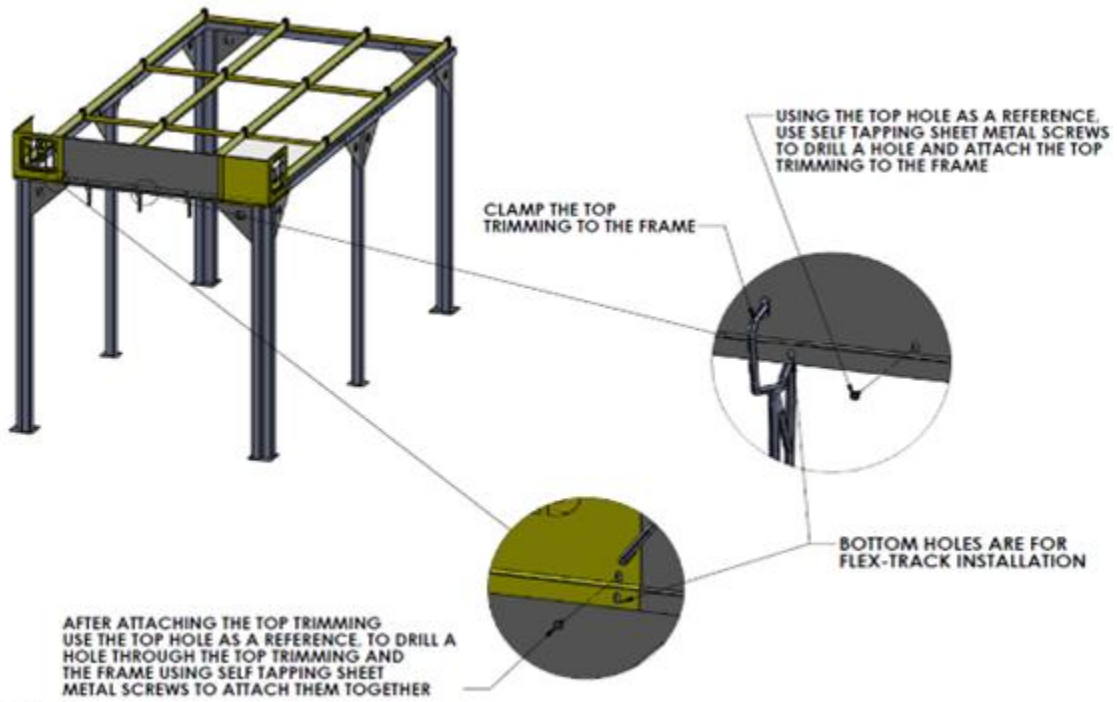

STEP 4

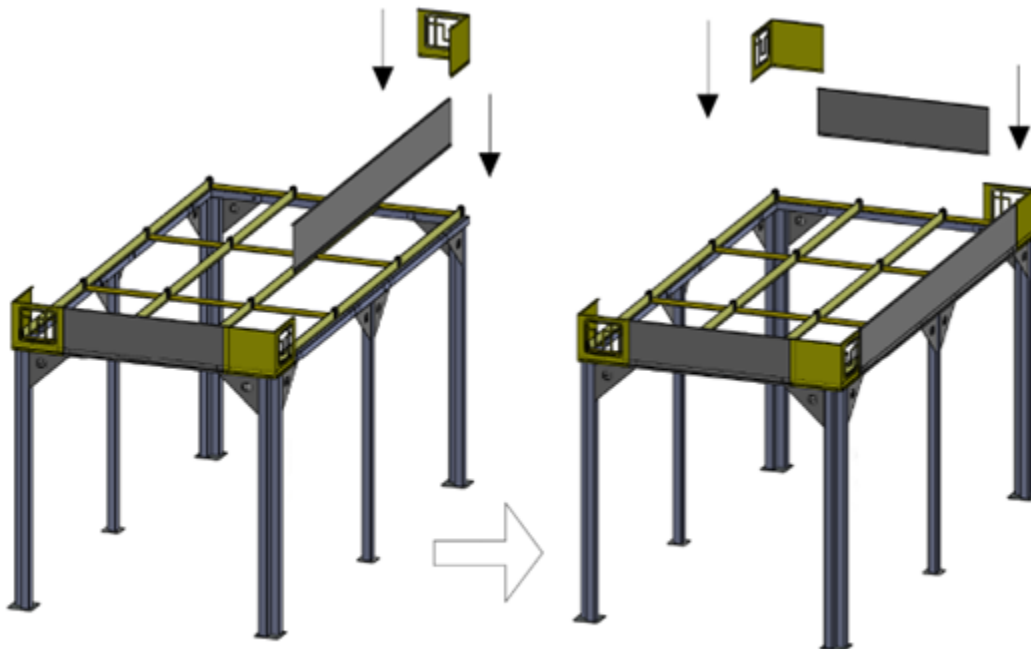

STEP 5

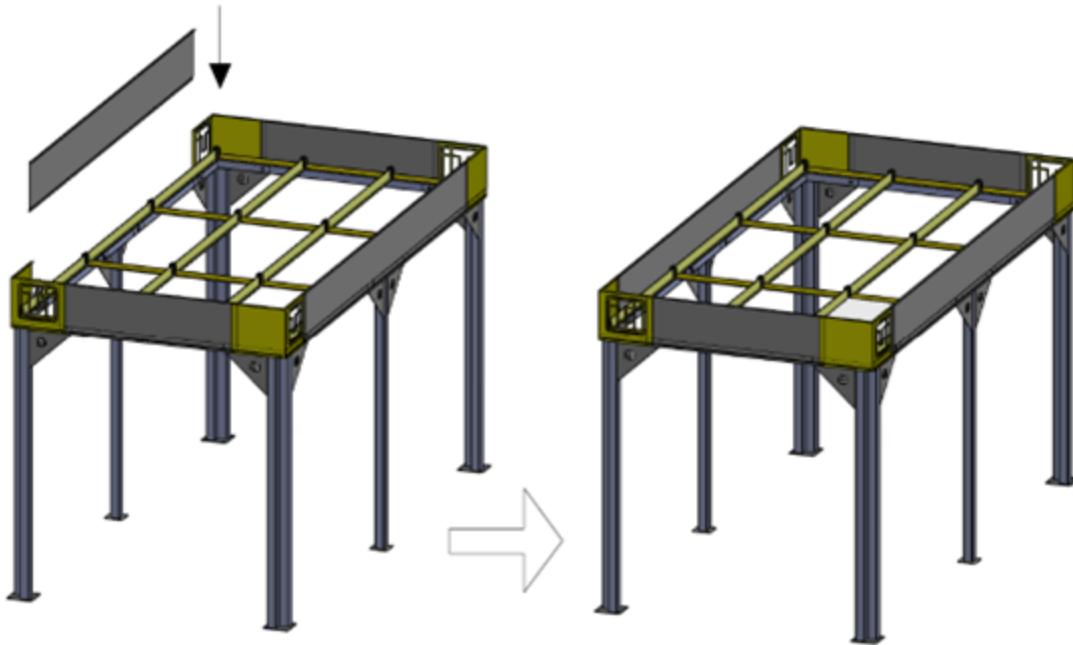

REPEAT STEPS 3-4

STEP 6

Note: To prevent scratching, leave protective plastic on steel trim until assembly is complete.

Installing the Ceiling Modules



**DROP CEILING ACCESSORIES
ONTO THE OPENINGS**

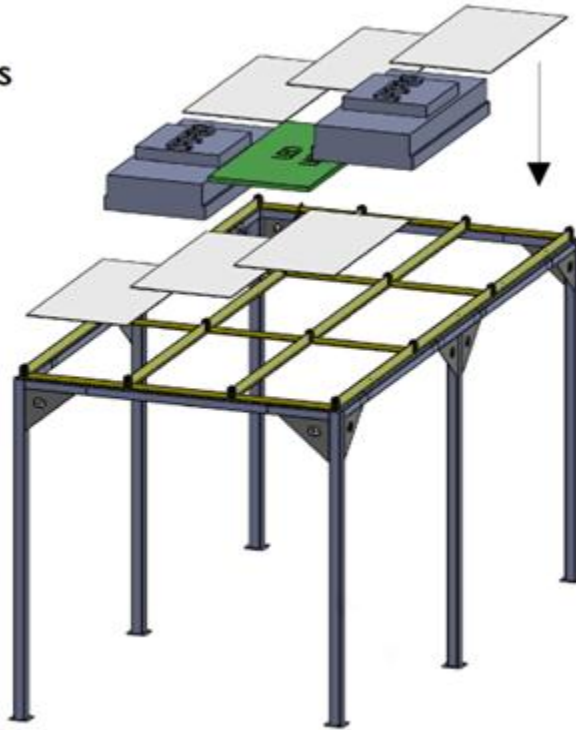

**NOTE: REFER TO THE ELECTRICAL
SECTION OF THE MANUAL FOR
WIRING DETAILS**

Refer to the drawing to determine where to place ceiling components.

If provided, secure down with Terra-provided Cleanroom Ceiling Clips. Use the 1-Arm Clip for joists with only one adjacent ceiling panel and use the 2-Arm Clip for joists with two adjacent ceiling panels. See Figures 1 thru 4.



Figure 1: 1-Arm Ceiling Clip



Figure 2: 2-Arm Ceiling Clip

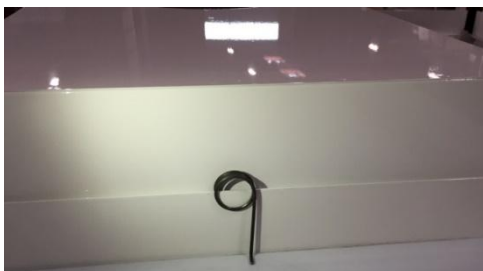

Figure 3: 1-Arm Ceiling Clip holds down a ceiling panel with a FFU installed on the opposite side of the joist.



Figure 4: 2-Arm Ceiling Clip simultaneously holds down two ceiling panels.



Curtain Panel Installation

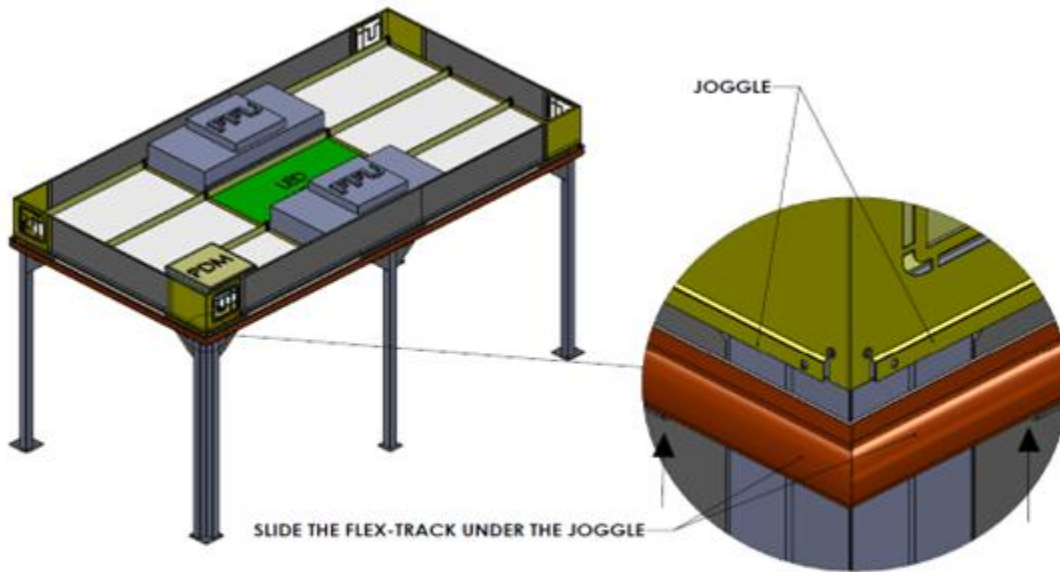

MAKE SURE THE FLEX-TRACKS TOUCH AT THE CORNERS AND TRIM THE FLEX-TRACK IF NECESSARY

STEP 1

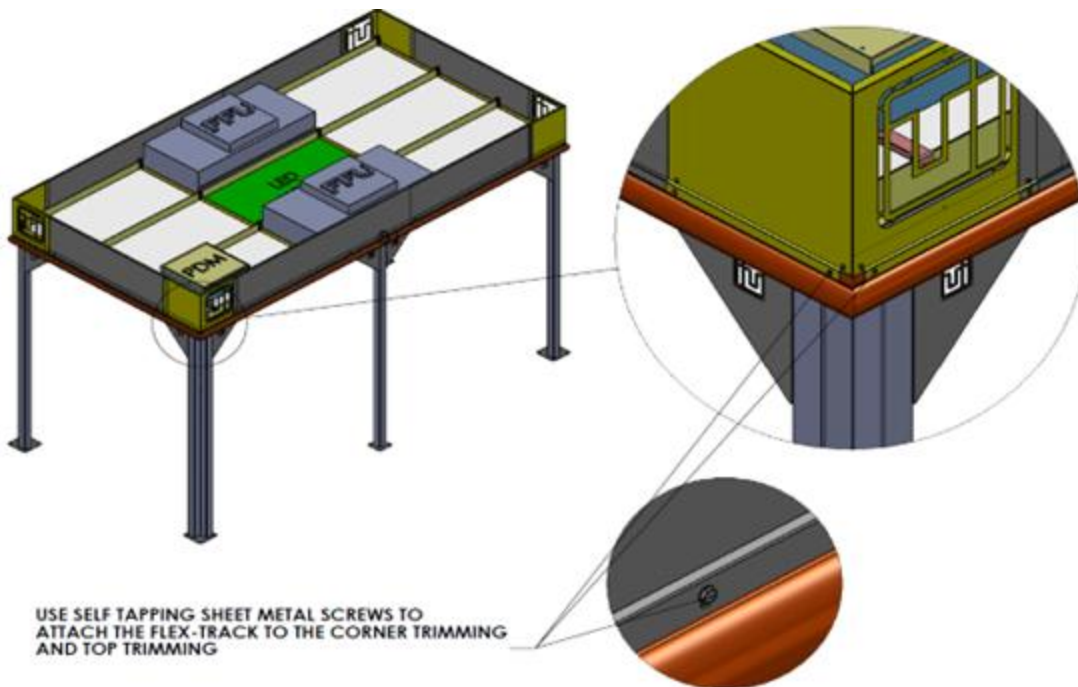

USE SELF TAPPING SHEET METAL SCREWS TO ATTACH THE FLEX-TRACK TO THE CORNER TRIMMING AND TOP TRIMMING

STEP 2

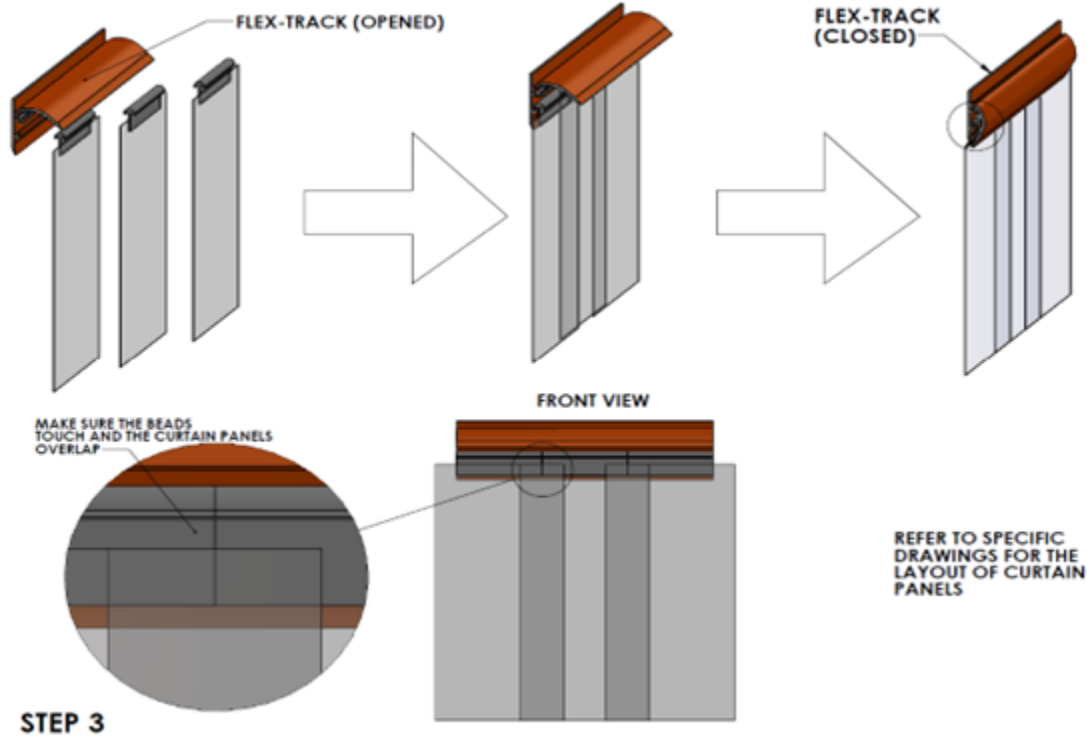

Fire Sprinkler System Installation

Once the cleanroom is set up, an ideal place for a fire sprinkler can be determined. Mark the desired location of the sprinkler system on a ceiling panel with tape or a pen/marker. Then, drill a 7/8" diameter hole into the ceiling panel. Install the brackets loosely on the two joists adjacent to the ceiling panel, which has the new hole for the sprinkler.

Put the sprinkler head under the ceiling panel in the hole from the cleanroom side and then screw the 1/2" NPT (National Pipe Taper), 2" long coupling on the top side of the ceiling panel. The 2" long coupling will prevent the sprinkler head from falling through the ceiling panel as the brackets are positioned. Thread the 1/2" NPT nipple on the coupling and then thread the flexible hose assembly (Figure A). Next, slide the brackets in a position so they align with the sprinkler head, then clamp the reducing nipple (the 5 1/2" metal piece that is part of the hose assembly {item 6, Figure A}) in place and then tighten the wing nut of the brackets to hold the assembly in position. For any further configurations, consult your specialized contractor.



COMPONENTS:

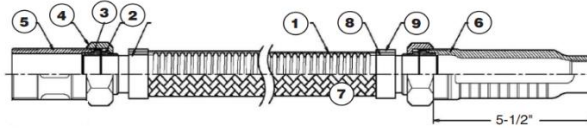

1. FLEXIBLE TUBE	304 STAINLESS STEEL
2. ISOLATION RING	NYLON 66
3. SEALING GASKET	EPDM
4. NUT	ZINC PLATED STEEL
5. NIPPLE 1"	ZINC PLATED STEEL
6. REDUCING NIPPLE	ZINC PLATED STEEL
7. BRAID	304 STAINLESS STEEL
8. COLLAR RING (INNER)	304 STAINLESS STEEL
9. COLLAR RING (OUTER)	304 STAINLESS STEEL
10. SQUARE BAR	ZINC PLATED STEEL
11. CENTER BRACKET	ZINC PLATED STEEL
12. 4" END BRACKET(S)	ZINC PLATED STEEL

CHARACTERISTICS:

- *Minimum bend radius Braided 3" (230 mm)
- *Flexibility Type: Limited

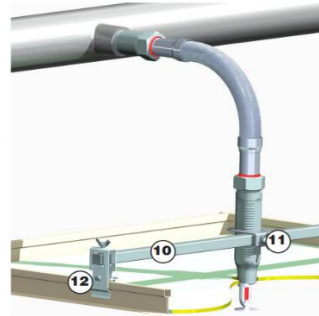

Figure A

How to Install Bracket for on Flexible Hose Assembly



[Flexible Fire Sprinkler Drop Hose Braided/Unbraided - YouTube](#)

Fire Sprinkler System

The turnkey cleanroom fire suppression system is an accessory that can be added to your cleanroom for precautionary fire safety. The system is designed in accordance with NFPA 318 in mind. Included in the kit are the sprinkler heads, piping, and connectors. A sprinkler is placed in the cleanroom ceiling panel, typically centered in the room, to maximize coverage area. The fire suppression system is suggested for cleanrooms under 300 square feet, installed in a non-hazardous location. For cleanrooms that are larger than 300 square feet and located in hazardous or seismic-rated locations or containing volatile or explosive chemicals, please contact a local safety officer to determine the appropriate fire suppression system.

3.0 Electrical Wiring

6600-20B-VL Power Supply Unit (PSU)

- A. Power Strip
- B. NEMA 5-15P plug (loose)
- C. Coiled Conduit + 3-conductor cable
- D. NEMA 5-20R receptacle + junction box
- E. NEMA 5-20P plug (pre-wired)
- F. Rocker Switch



Figure B: Power Supply Unit 6600-20B-VL Contents

Installing the Power Supply Unit (PSU)



NOTE

Each PSU has a maximum capacity of (3) FFUs and two (2) light fixtures

1. Punch out the precut knock outs in the door frame segment for the power supply.
2. Use a step drill bit to drill out the side joists aligning with the holes in the top of the door frame to make room for the conduit.
3. Uncoil the conduit and thread the wiring conduit up through the frame using some spare wire to the top of the frame member where the PSU will be mounted.
4. Wire and mount the rocker switch inside the door frame knock-out (Figs. C/D); use washers or spacers from switch hardware if a flush fit is desired.



Figure C: Switch Front

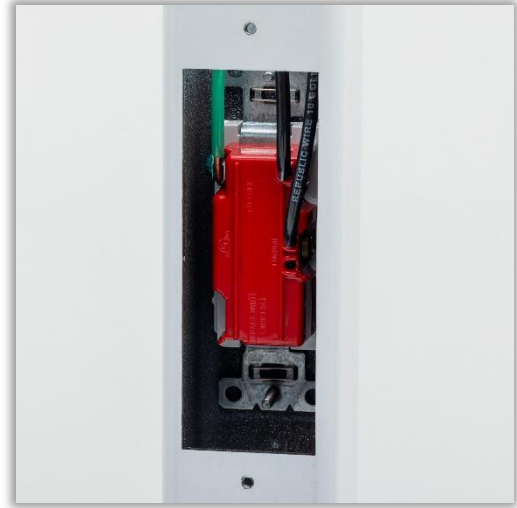

Figure D: Switch back (cover plate removed)

6. Install the provided NEMA 5-20R single-gang receptacle and junction box at the top end of the conduit.
7. Recoil the conduit and complete any remaining frame and ceiling installation steps **before proceeding to the final steps.**
8. Connect the provided power strip to the conduit junction box and place the power strip on one of the blank ceiling panels.
9. Fasten back plate to door frame reverse opening.
10. If necessary, swap the pre-wired NEMA 5-20P plug with the loose provided 5-15P plug
11. Plug the FFU and LED panels in to the power strip.
12. Turn on the power switch on the multi-outlet power strip (no power should be supplied at this point).
13. Once the power supply is installed and the cleanroom has been assembled, plug the cleanrooms PSU into your buildings wall outlet.

If the cleanroom was specified with more than three (3) FFUs, a second Power Supply Unit is required and is included in the cleanroom order. The second PSU should be installed in a similar manner to the primary PSU.



Fan Filter Unit Hard Wiring

⚠ WARNING: Disconnect the unit from the electrical power source before attempting any service.

To preserve the UL listing of Terra Fan Filter Units, Terra must configure them for hard-wiring. Cords are dressed to simplify this operation, which typically does not require an electrician.

1. Remove the blue pre-filter, which rests on top of the fan filter unit (Figure E).



Fig. E

2. Unscrew metal top panel of the electrical housing (Figure F) to expose wiring junction (Figure G).



Fig. F

3. Install cord grip as shown (Figures H, I) into appropriate opening.

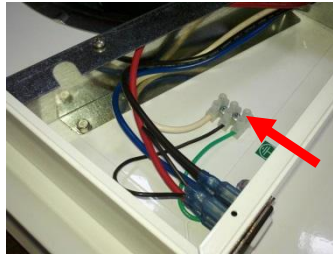

Fig. G



Fig. H

4. Thread the AC power chord through the cord grip and connect to wire port as shown (Figure J). Match the colors of the wiring, as indicated on the charts below. Tighten retaining screws to fasten wires.



Fig. I



Fig. J

5. Tighten cord grip to secure AC power chord.

6. Replace the metal panel on top of the electrical housing.

7. Replace the blue prefilter.

120V FFU Wiring				
Cable Wire	White	Black	Red	Green
Function	Neutral	Line	None (cut)	Ground
FFU Connector	White	Black	None	Green

220V FFU Wiring				
Cable Wire	White	Black	Red	Green
Function	None (cut)	Neutral	Line	Ground
FFU Connector	None	Black	Red	Green



4.0 Operation and Maintenance

Operation of the Modular Cleanroom is controlled by an on/off switch for lights and push buttons for the fan filter units, located near the access door. The Modular Cleanroom typically requires minimal maintenance. The filters provide effective operation for years under typical operating conditions. In fact, filter efficiency increases as the filter captures more and more particles. The filter does not require replacement until the backpressure it generates increases to the point that the system can no longer provide an adequate airflow velocity to maintain required particle counts. To monitor this condition, periodic testing with a particle counter and air velocity meter is recommended.

Filter Replacement

To replace the filter, disconnect system power and remove the fan filter unit from the top of the structure. Then position it to come through the 2' x 4' opening and into the cleanroom. See chart below for ordering information. Detailed replacement instructions on the next page.



WARNING: Never attempt to service or replace the filter without first disconnecting system power to the fan filter unit.

Terra Universal FFU Filter		
Type	Filter Size	TUI Part #
HEPA	2' x 2'	6601-27
	2' x 3'	6601-26
	2' x 4'	6601-25
ULPA	2' x 2'	6601-30
	2' x 3'	6601-29
	2' x 4'	6601-28

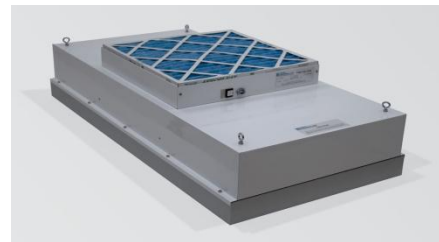

Removal and Replacement of the HEPA/ULPA Filter (Standard Unit, without room-side replaceable filter)



Warning: Disconnect the unit from the electrical power source before attempting any service.



Warning: The Standard Filter is protected with an expanded metal face screen. This is never to be used to handle the filter. It is only for protection against an accidental touch of the filter. Handle filter only by the frame.

Tools Required: Phillips Head Driver

1. Disconnect yellow power cable and remove unit from ceiling (see next page for recommended procedure).
2. Remove the 10 screws holding the HEPA/ULPA filter to the lid assembly.
3. Lift the lid assembly off the HEPA/ULPA filter (see figure below). Discard the used filter as per applicable regulations.
4. Carefully attach the new filter, being sure not to touch or otherwise damage the filter face.
5. Lift out the old pre-filter and drop in the new one.
6. Position the unit back in the ceiling grid and reconnect the unit to its power supply.

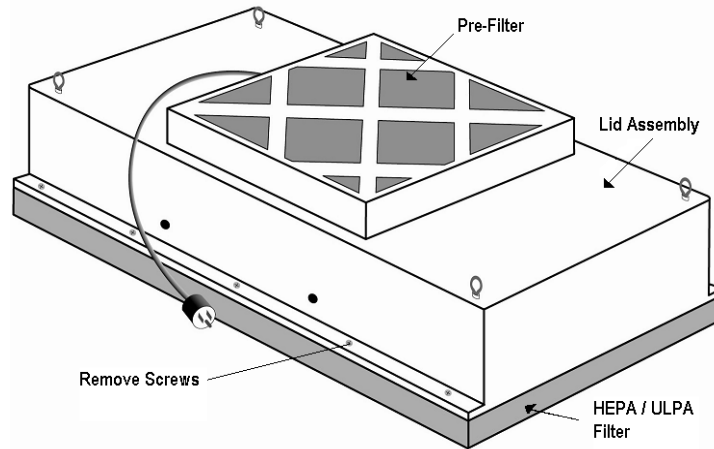

Note: Before replacing with a new HEPA/ULPA filter, carefully inspect the new filter for any visible damage.

Removing the Fan/Filter Unit from the Cleanroom Ceiling Grid



WARNING

Disconnect the unit from the electrical power source before attempting any service.

1. Disconnect the fan/filter unit from the power strip and roll up the power cord.
2. Attach double stick tape to all four sides of a polypropylene panel, as shown at right.
3. Place the polypropylene panel over the filter screen, making sure that it only adheres to the screen without overlapping the edges.
4. Push one side of the FFU up, rotate it 90° and lower it through the ceiling grid.
5. After replacing the filter, reverse these steps to reinstall the fan/filter unit in the ceiling grid.



Figure K



Figure L



Figure M



Figure N



Figure O



Figure P



Cleanroom Maintenance

Useful Tools

Wipes

Wipes are used more frequently than any other cleaning product or tool. Selection of wipes should be based on intended usage. When selecting wipes you should consider things such as particle-shedding properties, chemical residue of the wiper content, static properties, absorbency and size. When using wipes, wipe in one direction from top to bottom or left to right. Use only slight overlapping strokes. Remove surface spots with commercial cleaner and woven polyester wipes. If cleaning with isopropyl alcohol or similar cleaning agent, perform a full wipe-down of the sanitized area with deionized water.

Cavicide, Caviwipes and similar products contain ethylene glycol and benzethonium chloride, which are caustic chemicals that corrode stainless steel if not rinsed with water. After disinfecting with ethylene glycol or benzethonium chloride products, the affected area must be fully wiped down with deionized water and dried.



WARNING: Always check chemical compatibility before cleaning plastic surfaces. Although vinyl and polyurethane withstand exposure to a wide range of common cleaning agents, repeated exposure to strong chemicals can cause damage.

Vacuums

There are a variety of different Vacuums available for your cleanroom. Selection of a vacuum will depend heavily on the application and the type of cleanroom you have. With all different types of sizes and filtration systems, select the one you feel would best suit the cleaning needs of your room. Refer to the Parts & Accessories section. For more information log on to our website at Terrauniversal.com

Mini-Environment Cleaning Kits

The ITW Texwipe Mini Environment Cleaning Kits are ideal for cleaning corners and difficult-to-reach locations inside the cleanroom. The kits include a cleaning tool (18" and 24" handles, 1 polyester foam pad, and 6 mop covers), one production bag of dry and pre-wetted wipers and an informational brochure with instructions on how to clean your equipment.

Designed to facilitate cleaning, the mop head has a low, flat profile with rounded corners and is autoclaveable. The swivel joint allows the user to reach inaccessible areas and replaceable foam pad ensures that the mop cover conforms to the surfaces that are being cleaned. The polyester knit fabrics used for the wipers and mop covers will not contaminate isolator surfaces when used in cleaning and disinfection operations.



5.0 Spare Parts & Accessories

For replacement parts and accessories for your cleanroom order at TerraUniversal.com or Call 714-578-6000

Filter Replacement

Replacement Filters for Terra WhisperFlow™ Fan Filter Units		
Type	Size	TUI Part #
HEPA	2' x 2'	6601-27
	2' x 3'	6601-26
	2' x 4'	6601-25
ULPA	2' x 2'	6601-30
	2' x 3'	6601-29
	2' x 4'	6601-28

Cleanroom and Laboratory Wipers



Type	Size	Qty	TUI Part #
Cotton Wiper	9" x 9"	150/bag	5605-07
Cotton Wiper	12" 12"	75/bag	5605-02

White twill-patterned wiper, made of 100% long-staple cotton is tightly woven for strength and durability, while also clean and absorbent. Fabric is bias-cut and cross section of 120x60 threads per square inch. The woven twill pattern makes this wiper ideal for cleaning, polishing and burnishing magnetic disk media surfaces. Ideal in high heat applications, and absorbing aqueous and organic solvent spills. Suitable for Class 1000 and higher cleanrooms.

Laundered Polyester Wipers



Size	Standard 209E	Qty	TUI Part #
9" x 9"	Class 1	150/bag	5605-00
12" 12"	Class 10	75/bag	5605-08

Laundered wipers are ideal for critical environments where ultra-low particle/fiber generation and absorbent capacity is important. Soft yet durable construction cleans surfaces without scratching.



Casters



Type	TUI Part #
6" Locking Caster	6704-08

This 6" locking stainless steel swivel casters feature non-shedding polyurethane wheels. Capacity: 300 lbs. each. Order one per vertical post. Casters raise the frame 7.125". If casters are ordered, the frame will be made shorter to keep the floor to filter face dimension to specification.

MicroVac Portable Cleanroom Vacuum Cleaner



Type	TUI Part #
110 Vac/60Hz	5100-00
220 Vac/50 Hz	5100-00-220

The MicroVac™ is a portable vacuum cleaner suitable for use in cleanroom environments. It incorporates a four-stage filter system to remove particles and dust from the air before returning the air to the workplace. The small size, light weight, and flexible attachments of this cleaner make it ideal for cleaning tight corners and delicate equipment that a larger cleaner just can't reach!

HEPA-Filtered Vacuum Cleaner



Type	TUI Part #
110 Vac/60Hz	1001-00

This HEPA-Filtered Vacuum Cleaner combines the power and capacity for heavy-duty operation with a lightweight, compact design that makes it as convenient as it is effective. The unit's HEPA (High Efficiency Particulate Air) filter removes 99.999% of all particles 0.3µm or larger, exceeding federal standards and accepted HEPA filtration levels.

ULPA Filtration Vacuum Cleaner



Type	TUI Part #
115 Vac/60Hz	1764-00
220 Vac/50 Hz	1764-00-220

This Cleanroom Vacuum Cleaner is used for cleaning the workplace or picking up spills of hazardous dust and particles. Its unique four-stage filter system removes particles 0.12 microns in size at 99.9995% efficiency, before returning the air to the workplace.



LED Light Panel



Type	TUI Part #
120-277V Vac/60Hz	3800-41C

Post Base Cover



Type	TUI Part #
Base Cover	6601-65

Fire Sprinkler System



Type	TUI Part #
Turnkey Cleanroom Fire Suppression System	6601-05-01

Black Cord Adapter Power Cord

For connection of light or fan filter unit to the power strip



TUI # 6601-13
4-Pin adapter cable for fan/filter units



TUI # 6601-14
3-Pin adapter cable for LED light panels



Installation and Operating Guide

ValuLine® Softwall Modular Cleanroom

© Copyright 2026 Terra Universal Inc. All rights reserved. • Revised Feb. 2026 • Document No. 1788-04

5.0 Warranty



<https://www.terrauniversal.com/warranty/>

*Thank you for ordering from
Terra Universal!*