



IMPORTANT SAFETY INSTRUCTIONS READ AND SAVE THESE INSTRUCTIONS

<p>Proprietary Notice This manual pertains to proprietary devices manufactured by Terra Universal, Inc. Neither this document nor any portion of it may be reproduced in any way without prior written permission from Terra Universal.</p>	<p>Safety Notice A thorough familiarity with all operating guidelines is essential to safe operation of the product. Failure to observe safety precautions could result in poor performance, damage to the system or other property, or serious bodily injury or death. The following symbols are intended to call your attention to two levels of hazard involved in operation.</p>	
<p>Terra Universal makes no warranties applying to information contained in this manual or its suitability for any implied or inferred purpose. Terra Universal shall not be held liable for any errors this manual contains or for any damages that result from its use.</p>	 CAUTION	<p>Cautions are used when failure to observe instructions could result in significant damage to equipment.</p>
	 WARNING	<p>Warnings are used when failure to observe instructions or precautions could result in injury or death.</p>
<p>The information presented here is subject to change without notice.</p>		

1.0 Introduction

This manual provides information on installing and operating Terra Universal's Reverse Air-Flow Room-Side WhisperFlow® Fan/Filter Unit with dust collection pan. The Fan/Filter unit converts any room into a negative pressure isolation/containment room. By studying this document carefully, you can be assured of a long, efficient service life from the unit.

2.0 Operation

The unit consists of a ¼ HP, thermally protected, variable speed motor that provides precise, fully adjustable airflow and drives a backward-curved centrifugal blower. Air is drawn into the unit through the dust collection pan and exhausted out through the blue MERV 7 filter. The MERV 7 filter protects against dust and debris from falling into the impellor. It can be replaced with a duct collar (ordered separately) for ducted exhaust. The motor is controlled by an electrical speed dial control. This dial can function as ON/OFF for the blower and starts from high to low flow rates. The dust collector pan can integrate with bag-in/bag out (BIBO) systems and is easily removed for cleaning or maintenance.

3.0 Installation

The Reverse Flow Fan/Filter unit is designed to fit on top of a Terra Laminar Flow Hood or standard clean room ceiling grid. Threaded receptacles at each corner accommodate the mounting platform, which also holds the MERV-7 filter in place.



WARNING:
To reduce the risk of fire, electric shock, or injury to persons, do not use this fan with any solid-state speed control device, and observe the following:

- Use this unit only in the manner intended by the manufacturer. If you have questions, contact the manufacturer.
- Before servicing or cleaning unit, switch power off at service panel and lock the service disconnecting means to prevent power from being switched on accidentally. When the service disconnecting means cannot be locked, securely fasten a prominent warning device, such as a tag, to the service panel.
- Installation work and electrical wiring must be done by qualified person(s) in accordance with all applicable codes and standards, including fire-rated construction.
- If the supply cord is damaged, it must be replaced by the manufacturer, its service agent, or similarly qualified persons in order to avoid a hazard.
- When cutting or drilling into a wall or ceiling, do not damage electrical wiring and other hidden utilities.

4.0 Start up



WARNING:
Keep unit disconnected from power supply during inspection.

Prior to providing power to the unit, check that no damage has occurred during shipping. This can be accomplished via a visual check to make sure there are no visible dents or penetrations. If the unit is intact, remove the blue MERV-7 and manually rotate the fan wheel to make sure it is not in contact with any stationary parts and that there are no visible loose screws or bolts obstructing the wheel's rotation. After installation, with power applied, the fan will rotate and filtered air will exit the HEPA filter.

5.0 Cleaning and Maintenance



WARNING:

Disconnect from power supply before servicing unit. When replacing filter, the new filter is to be installed in the same manner as the filter it replaces.

The scheduled maintenance of the unit depends on the installed location and consists of changing the HEPA filter. The HEPA filter cannot be cleaned and must be replaced when the laminar flow rate falls below 70 feet/min.

The blue MERV-7 filter should remain clean and not require replacement when the unit is actively used. This is because clean filtered air is pushed up through the MERV-7 filter.

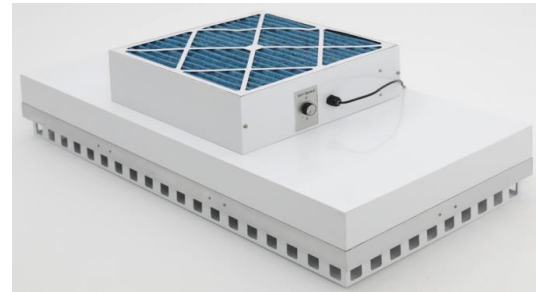

6.0 Specifications

Housing:	White powder coated cold-rolled steel or 304 stainless steel
HEPA Filter:	99.99% efficient on removal of particles 0.3 microns and larger.
MERV-7 Filter:	20" x 20" x 1" - 30% efficient ASHRAE rated
Blower:	Backward-curved centrifugal type factory balanced. Entire motor/blower assembly is removable from top of housing for service.
Motor:	1/4 HP Direct drive, energy efficient. Permanent split capacitor type. Thermally protected with automatic overload reset.
Electrical:	Variable speed motor is controlled by an electrical speed dial control. This dial can function as ON/OFF
Power Cord:	None supplied
Face Grille:	Dust Collection Pan
Support:	Threaded screw receptacles provided for insertion of optional eyebolts

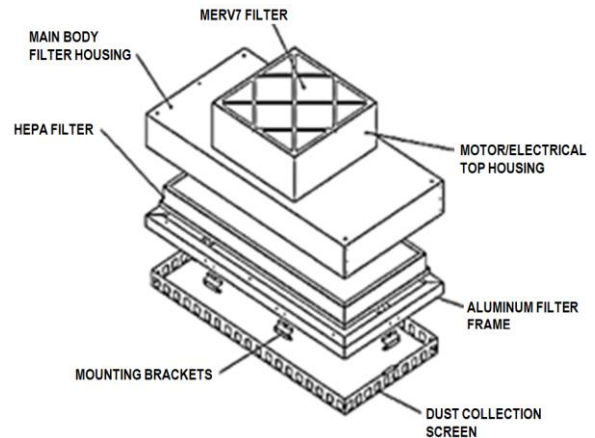

REVERSE AIR-FLOW WHISPERFLOW® PERFORMANCE DATA			
Unit Size (ft.)	Filter	Sound (dB) @90FPM	Air Flow (CFM) @ Max. Speed
2' x 2'	HEPA (RSR)	60	387 CFM
2' x 4'	HEPA (RSR)	60	353 CFM

PRODUCT DIMENSIONS					
Unit Size (ft.)	Active Filter Area (sq.ft)	W (in)	L (in)	H (in)	Weight (lbs.)
2' x 2' (RSR)	2.2'	23.625"	23.625"	17.975"	40
2' x 4' (RSR)	5.2'	47.625"	23.625"	17.975"	60

REVERSE AIR-FLOW WHISPERFLOW® ELECTRICAL DATA						
Unit Size (ft.)	Filter	Motor HP	Voltage	Full Load Amps	Frequency (Hz)	Power Consumption (Watts)
2' x 2'	HEPA	¼	115V	1.35	60	160
2' x 2'	HEPA	¼	230V	0.66	50/60	125/170
2' x 4'	HEPA	¼	115V	1.35	60	160
2' x 4'	HEPA	¼	230V	0.66	50/60	125/170

Specification Notes:

- All FFU data is based on a standalone unit using 1" clean filters.
- Data will vary depending on filter media and configurations with other products/systems, such as ductwork or hoods.

7.0 Filter Replacement

WARNING:

For applications involving risk of exposure to harmful particulates or pathogens in the filter media, use appropriate PPE and reference your facility's protocol for safe removal and disposal of filters.



1. Remove the dust collection screen covering the filter that is held in place with screws (See Figure 1). This screen protects the filter from damage and helps collect particles that dislodge from the filter from being reintroduced into the surrounding environment.



Figure 1: White caps must be removed to expose the screws that hold the outer screen to the fan module housing.



Figure 2: View of the filter with the outer screen removed

2. Rotate the metal tabs that help hold the HEPA filter in place (See Figure 3).



Figure 3: Filter-face grille's metal tabs

3. Gently let the used filter drop down.
4. Wipe any residual gel from the knife-edge of the fan module still in the ceiling to prepare for the replacement filter.
5. Position your new filter carefully before pushing it into place; the knife-edge of the fan module should be centered in the channel (equal amounts of gel on both sides). Figure 4 shows the gel-filled channel of the RSR filter.

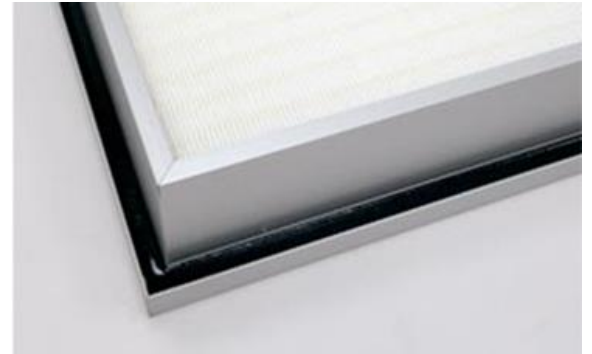

Figure 4: Gel-filled channel of RSR filter

6. Rotate the metal tabs to lock in the new HEPA filter.
7. Reinstall the dust collection screen by pushing up on the friction catches until the screen clicks into place.

8.0 Warranty

<https://www.terrauniversal.com/warranty>