



Terra Universal Product Manual Document No. 1788-49

WhisperFlow® Fan Filter Units

© Copyright 2023 Terra Universal Inc. All rights reserved • Revised May 2026 •

Your Comprehensive
 Equipment Source

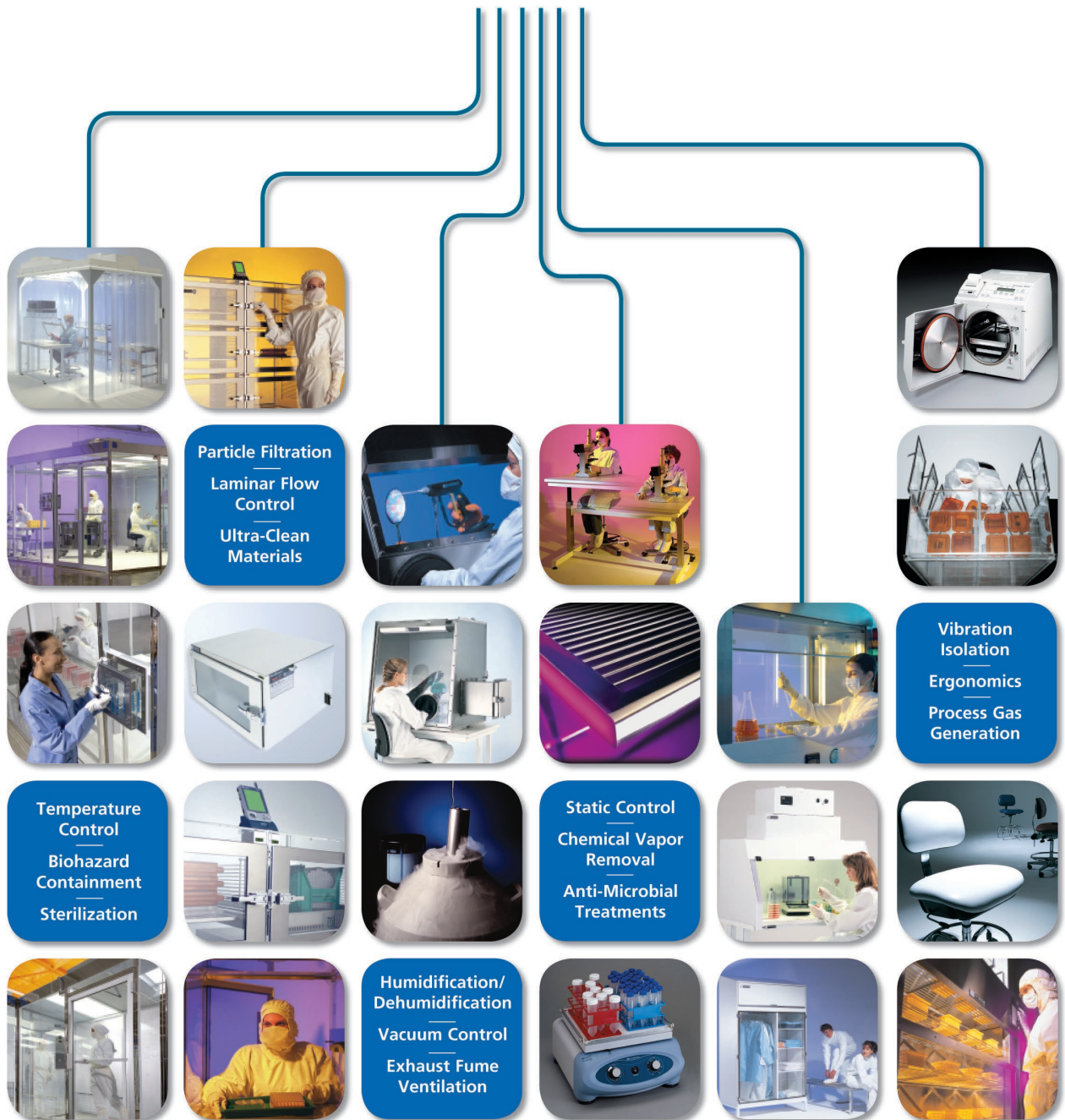



WhisperFlow® Fan Filter Units

1. General Information	3
1.1 Part Numbers Covered by this Manual.....	4
2. Safety	5
3. Start-Up.....	6
3.1 Installation	6
3.2 WhisperFlow® FFUs	7
3.3 WhisperFlow® Reverse Airflow FFUs	9
3.4 WhisperFlow® Smart® FFU with EC Motor.....	11
3.4.1 120V Configuration (default).....	12
3.4.2 220V Configuration	12
3.4.3 EC Motor Control Card.....	14
4. Filter Cleaning and Replacement.....	18
4.1 When Should I Change My Filter?	18
4.2 Top-Side Filter Replacement	19
4.3 Room-Side Gel Seal Filter Replacement (BIBO compatible)	21
4.3.1 Gel Seal Filter Damage Inspection	23
5. Wiring Diagrams	26
6. Speed Configuration with Power Distribution Module (PDM).....	28
6.1 How to Connect Low Mode for Standalone Fan Filter Units	29
7. Testing	31
8. Troubleshooting	31
9. Replacement Parts.....	31
10. Accessories	32
11. Warranty.....	33



WhisperFlow® Fan Filter Units

1. General Information

This manual documents the operational guidelines for Terra Universal's WhisperFlow® Standard, Smart® EC (Electronically Commutated) Motor, Narrow, Reverse-Flow, and Smart® Reverse-Flow fan filter units.

FFUs have several applications. They are most commonly used for laminar flow hoods, and in cleanrooms. For cleanrooms, FFU's are compatible with [Terra's Control Panels and Power Distribution Modules](#) (PDMs). PDMs and control panels are specifically designed to simplify electrical connections, reduce headaches, and get cleanroom projects completed faster. No hardwiring is required to connect and provide power to the fan filters, lights, and duplex PDMs. Not only are these systems much faster and easier to connect, but they also reduce the complexity and frequency of electrical touchpoints that can lead to human error.

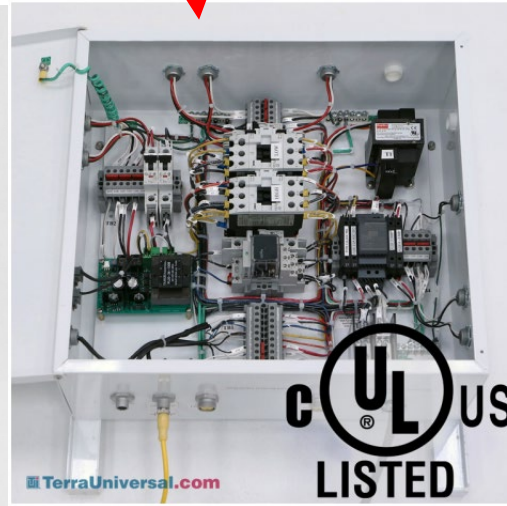
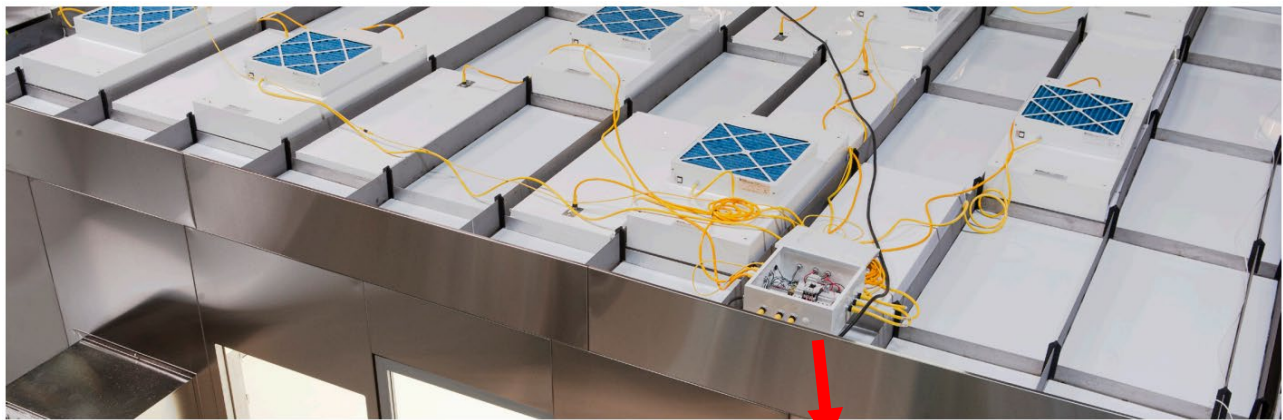



WhisperFlow® Fan Filter Units

1.1 Part Numbers Covered by this Manual

Fan Filter Unit Models			
<u>WhisperFlow® Room-Side Replaceable</u>	<u>WhisperFlow® Standard</u>	<u>WhisperFlow® Smart®</u>	<u>WhisperFlow® Reverse-Flow</u>
6601-24A-UR-220	6601-24-U-220	6601-24B-UR-EC	6601-24-UVSS
6601-24A-UR	6601-24-U	6601-24B-HRSS-EC	6601-24-UVFSS
6601-24A-HRSS-220	6601-24-HSS	6601-24B-HR-EC	6601-24-UV-220-CE
6601-24A-HR-220	6601-24-H2	6601-24A-USS-EC	6601-24-UV-220
6601-24A-HR	6601-24-H-NC	6601-24A-U-EC	6601-24-UV
6601-24-URS-220	6601-24-H-CA	6601-24A-HSS-EC	6601-24-HVSS
6601-24-HRSS	6601-24-H-220	6601-24A-H2-EC	6601-24-HVF-220
6601-23A-UR-220	6601-24-H	6601-24A-H-EC-CA	6601-24-HVF
6601-23A-UR	6601-23-U-220-CE	6601-24A-H-EC	6601-24-HV-220-CE
6601-23A-HRSS-220	6601-23-U-220	6601-23B-URSS-EC	6601-24-HV-220
6601-23A-HRSS	6601-23-U	6601-23B-UR-EC	6601-24-HV
6601-23A-HR-220	6601-23-HSS	6601-23B-HR-EC	6601-23-UVSS
6601-23A-HR	6601-23-H2	6601-23A-USS-EC	6601-23-UVFSS
6601-22A-UR-220	6601-23-H-CA	6601-23A-U-EC	6601-23-UV-220-CE
6601-22A-UR	6601-23-H-220	6601-23A-HSS-EC	6601-23-UV
6601-22A-HRSS-220	6601-23-H	6601-23A-HRSS-EC	6601-23-HVF-220
6601-22A-HRSS	6601-22-U-220-CE	6601-23A-H-EC-CA	6601-23-HVF
6601-22A-HR-220	6601-22-U-220	6601-23A-H-EC	6601-23-HV-220-CE
6601-22A-HR	6601-22-U	6601-22B-URSS-EC	6601-23-HV-220
	6601-22-HSS-220	6601-22B-UR-EC	6601-23-HV
<u>WhisperFlow® Narrow</u>	6601-22-HSS	6601-22B-HR-EC	6601-22-UVSS
6601-1648-H-220	6601-22-H-CA	6601-22A-USS-EC	6601-22-UVFSS
6601-1648-H	6601-22-H-220	6601-22A-U-EC	6601-22-UV-220-CE
6601-1636-HS	6601-22-H	6601-22A-H-EC-CA	6601-22-UV-220
6601-1636-H-220-CE		6601-22A-H-EC	6601-22-UV
6601-1636-H-220	<u>Ducted Filtered Diffusers</u>		6601-22-HVF-220
6601-1636-H	6601-24-HDR	<u>WhisperFlow® Smart® Reverse-Flow</u>	6601-22-HVF
6601-1624-HS-220	6601-24-HD	6601-24A-UVSS-EC	6601-22-HV-220-CE
6601-1624-HS	6601-23-HDR	6601-24A-HV-EC	6601-22-HV-220
6601-1624-H-220-CE	6601-23-HD	6601-23A-UVSS-EC	6601-22-HV
6601-1624-H-220	6601-22-HDR	6601-23A-HV-EC	6601-22B-HVR
6601-1624-H	6601-22-HD	6601-22A-UVSS-EC	6601-22B-HVR-220
		6601-22A-HV-EC	6601-24B-HVR
			6601-24B-HVR-220



2. Safety

Proprietary Notice

This manual pertains to proprietary devices manufactured by Terra Universal, Inc. Neither this document nor any portion of it may be reproduced in any way without prior written permission from Terra Universal.

Terra Universal makes no warranties applying to information contained in this manual or its suitability for any implied or inferred purpose. Terra Universal shall not be held liable for any errors this manual contains or for any damages that result from its use.

Safety Notice

A thorough familiarity with all operating guidelines is essential to safe operation of the product. Failure to observe safety precautions could result in poor performance, damage to the system or other property, or serious bodily injury or death. The following symbols are intended to call your attention to two levels of hazard involved in operation.



CAUTION

Cautions are used when failure to observe instructions could result in significant damage to equipment.



WARNING

Warnings are used when failure to observe instructions or precautions could result in injury or death.

The information presented here is subject to change without notice.

To reduce the risk of fire, electric shock, or injury to persons, observe the following:

- Do not use this unit for anything other than the intended manner of the manufacturer. Contact the manufacturer for additional clarification.
- Before servicing the unit, or replacing a filter, switch power to OFF at the service panel and lock it to prevent accidental power activation. When the panel cannot be locked, securely fasten a prominent warning device, such as a tag, to the service panel.
- When the removal/disconnection of either filter is required due to service or component replacement, the replacements are to be remounted as previously installed.
- Qualified person(s) must install the unit and configure the electrical wiring adhering to all applicable codes and standards, which includes fire-rated construction. All metal components must be properly grounded.
- Do not damage or interfere with electrical wiring and other hidden utilities when cutting or drilling into the wall or ceiling.
- Check the ECM unit's supply cord for damage, if it is damaged it must be replaced by the manufacturer, its service agent, or similarly qualified persons to avoid a hazard.

Critical Operation Conditions

- DO NOT TOUCH THE FILTER SURFACE WITH HANDS, TOOLS, OR OTHER OBJECTS.
- DO NOT STACK OR PLACE ANY ITEMS ON TOP OF THE FILTER UNITS.
- Filters are to be handled and lifted only by the frame to prevent damage to the HEPA or ULPA media.
- When in operation, ensure that all packaging materials are removed and that airflow is unrestricted.
- Call a certified electrician for any electrical project to avoid the risks of injury, fire hazards, code violations, or potential damage to your electrical system and components. Qualified electrical and wiring expertise ensures that the final installation meets all applicable codes and achieves fire-rated construction.
- The filter media is extremely sensitive and can damage easily. The screen only protects against an accidental 'touch' of the filter media. Avoid touching and damaging the HEPA filter because the warranty will void.
- Never place anything on the filter. Always place filter on its side to avoid damage.



CAUTION



3. Start-Up

3.1 Installation

The fan filter unit is designed to fit on top of a Terra Laminar Flow Hood or standard clean room ceiling grid. It includes 1/4-20 thread holes on corners for guy-wire suspension. Room-side replaceable filters are packaged separately for jobsite installation by others.

1. Remove all packaging material from the shipping box (Figure 1).
2. Perform a thorough visual inspection to ensure no damage has occurred during shipping. Check that there are no visible dents or penetrations on the filter face and grille. If damage is discovered, contact the freight company to file a damage claim immediately.
3. Remove the pre-filter and manually rotate the fan wheel to make sure it does not come in contact with any stationary parts and that there are no visible loose screws or bolts obstructing the wheel's rotation.
4. Verify unit is sanitary for cleanroom placement.
5. Optional: fasten the eyebolts into each corner of the lid assembly.
6. Lift the unit into the ceiling and position onto the ceiling grid. If the grid is not secured, fasten to an engineered support system with chain, s-hooks and eyehooks (usually supported with wires).
7. Confirm fan dimensions are aligned with grid dimensions.
8. Raise the unit and secure with support system method suspended from a structural support bracing.
 - a. Minimum clearance of 1 foot (including fixtures, ducts and pipes) on all sides and at least 2 feet of vertical clearance between the FFU inlet and ceiling for proper air supply.
9. Connect the 4-pin power plug to the unit, set the speed switch to the desired position (units are shipped from the factory with the speed switch set to medium), and turn on the external power switch. With power applied, the fan will rotate, and filtered air will exit the HEPA filter.

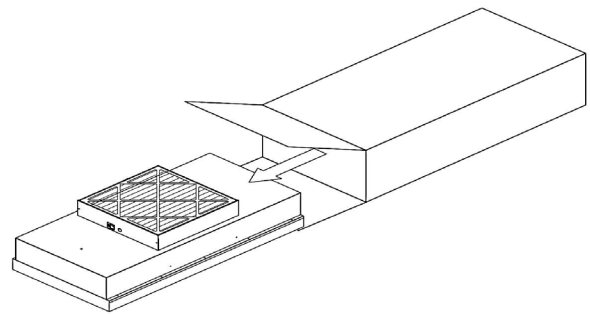

Figure 1: Unboxing

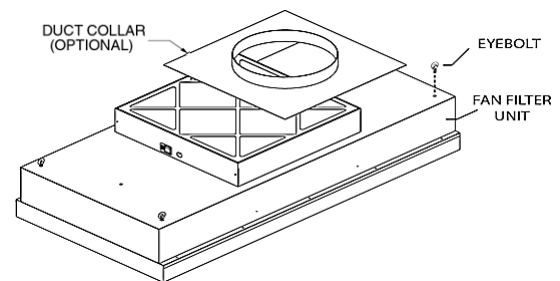

Figure 2: Hanger Supports



WARNING

To avoid thermal overload on FFU's with Permanent Split Capacitor (PSC) motors, do not use LOW speed switch when the FFU is connected to a PDM.

Note: After completing the Initial Setup, validation may be performed by a third-party testing service for HEPA filter integrity (leak-testing), Air Changes per Hour and particle counter measurements to verify ISO 5 particle levels. Third-party testing should take place within the intended cleanroom or another controlled environment to ensure an accurate evaluation of its performance.



WhisperFlow® Fan Filter Units

3.2 WhisperFlow® FFUs

The WhisperFlow® fan filter unit has a 3-speed switch (low, medium, high) with a ¼ Hp permanent split capacitor motor. The internal baffling plate and diffuser panel provide quiet uniform air flow across the filter face. FFU includes permanently-lubricated bearings, factory balanced forward-curved blower wheel, ¼-20 thread holds on corners for guy-wire suspension, and a filter membrane constructed from micro-glass. FFU uses FDA-approved silicon sealant and a 30% ASHRAE rated MERV 7 pre-filter, 20" x 20" x 1". The unit uses standard UL 900 filters and is tested to IEST recommended standards. Room-side replaceable filter models feature fire retardant phosphorous free polyurethane gel-sealant to seat against a knife-edge on the fan housing and easy-open clips for fast filter replacement from the room side without breaching the cleanroom ceiling. The low profile design is ideal for cleanrooms with limited ceiling space.

There is challenge port fitting for a 3/8"-diameter challenge port, which can be used to take differential pressure measurements to monitor filter performance or insert aerosols for leak-test certification. Port is capped when not in use.

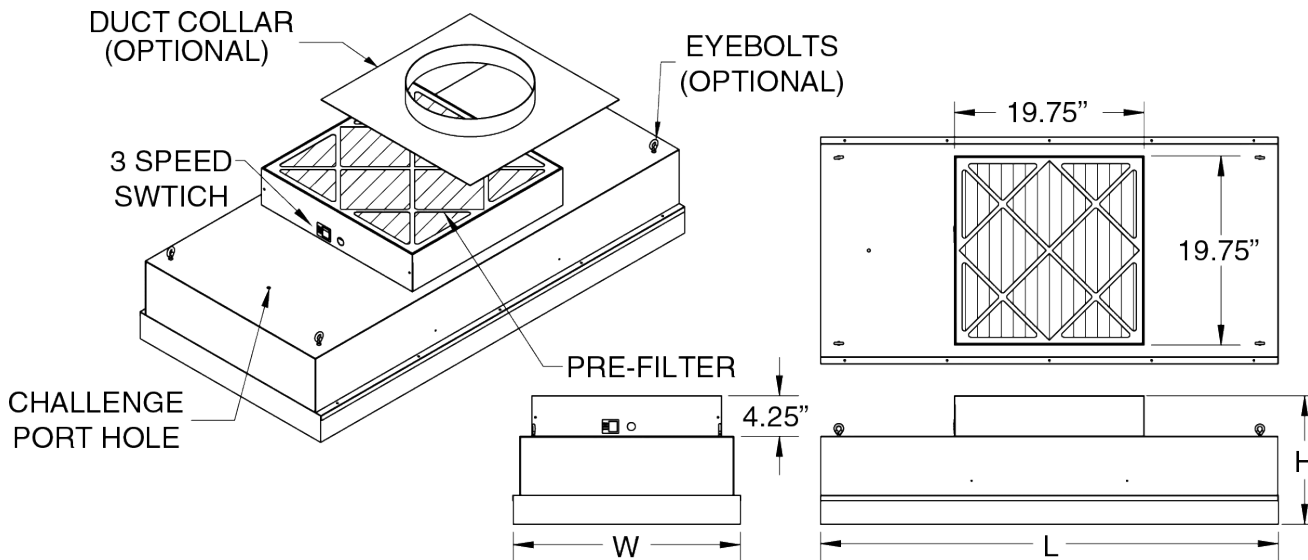

PRODUCT DIMENSIONS					
Nominal Unit Size (ft.)	Active Filter Area (sq. ft.)	W (in)	L (in)	H (in)	Weight (lbs.)
2' x 4'	7.2'	23.63"	47.56"	12.60"	71
2' x 4' (RSR)	5.2'	23.63"	47.63"	14.66"	71
2' x 3'	5.3'	23.63"	35.56"	12.60"	53
2' x 3' (RSR)	3.7'	23.63"	35.63"	14.66"	53
2' x 2'	3.4'	23.63"	23.56"	12.60"	44
2' x 2' (RSR)	2.2'	23.63"	23.63"	14.66"	44



WhisperFlow® Fan Filter Units

WHISPERFLOW® FFU PERFORMANCE DATA					
Nominal Unit Size (ft.)	Filter	Sound (dB) @90FPM	AIR FLOW (CFM)		
			HIGH	MED	LOW
2' x 4'	HEPA	49	800	720	590
2' x 4'	HEPA (RSR)	49	800	720	590
2' x 4'	ULPA	49	660	640	580
2' x 4'	ULPA (RSR)	49	660	640	580
2' x 3'	HEPA	49	675	630	560
2' x 3'	HEPA (RSR)	49	600	560	540
2' x 2'	HEPA	49	450	440	420
2' x 2'	HEPA (RSR)	49	360	330	300

WHISPERFLOW® FFU ELECTRICAL DATA								
Nominal Unit Size (ft.)	Filter	Motor HP	Voltage	Full Load Amps	Frequency (Hz)	Power Consumption (Watts)		
						HIGH	MED	LOW
2' x 4'	HEPA	1/4	120	3.8	60	420	380	360
2' x 4'	HEPA	1/4	208-230/240	1.6/1.8	60/50	380	310	240
2' x 4'	HEPA (RSR)	1/4	120	3.8	60	420	380	360
2' x 4'	HEPA (RSR)	1/4	208-230/240	1.6/1.8	60/50	380	310	240
2' x 4'	ULPA	1/4	120	3.8	60	440	425	415
2' x 4'	ULPA (RSR)	1/4	120	3.8	60	440	425	415
2' x 3'	HEPA	1/4	120	3.8	60	330	300	285
2' x 3'	HEPA	1/4	208-230/240	1.6/1.8	50/60	300	270	230
2' x 3'	HEPA (RSR)	1/4	120	3.8	60	310	290	250
2' x 3'	HEPA (RSR)	1/4	208-230/240	1.6/1.8	50/60	300	270	230
2' x 2'	HEPA	1/4	120	3.8	60	300	250	230
2' x 2'	HEPA	1/4	208-230/240	1.6/1.8	50/60	230	190	180
2' x 2'	HEPA (RSR)	1/4	120	3.8	60	320	235	200
2' x 2'	HEPA (RSR)	1/4	208-230/240	1.6/1.8	50/60	230	190	180

Notes:

- Performance tested in accordance with the (ANSI/AMCA 210-07), (ANSI/ASHRAE 51-07) test standards for Certified Aerodynamic Performance Rating.
- Sound levels were measured with unit installed in a gasketed ceiling, in a standard room. Sound levels in dB were measured at a distance of 12 inches from the filter face, with the unit set to produce 90 fpm average face velocity. (Note that data is for a clean filter only. If fan speed is increased to compensate for filter loading the noise level will increase.)
- The unit set to produce 90 fpm average face velocity.
- All data is based on a unit with a 1" pre-filter and clean filter. Results will vary depending on filter media and ducting used.
- 90 fpm values are based on active filter face area.
- Heat Gain: BTU = Watts x 3.413
- Units tested 2019



3.3 WhisperFlow® Reverse Airflow FFUs

The exhaust flow fan filter unit converts any room into a negative pressure isolation/containment room with a HEPA filter that is 99.97% efficient at 0.3µm particle diameter. The unit mounts into the ceiling bay with ¼-20 UNC threaded inserts available on the corners for guy-wire suspension. The MERV 7 filter is 30% ASHRAE rated with an FDA-approved acrylic urethane sealant that prevents air leakage from the inside housing. There is a removable yellow power cord with a 4-pin connector that provides easy installation to Terra cleanrooms. This connector may be used with an optional wall plug adapter or may be removed entirely to hard-wire the FFU. The optional duct collar attachment allows connection to ducting system for safe exhaust outside of room.

The unit consists of a ¼ HP, thermally protected, variable speed motor that provides precise, fully adjustable airflow and drives a backward-curved centrifugal blower. The dust collection pan collects particles that fall off the outside of the filter to prevent them from being reintroduced into the surrounding environment. Air is drawn into the unit through the dust collection pan and exhausted out through the blue MERV 7 filter. The MERV 7 filter protects against dust and debris from falling into the impellor. The motor is controlled by an electrical speed dial control and this dial can function as ON/OFF for the blower starting from high to low flow rates. The dust collector pan can integrate with bag-in/bag-out (BIBO) systems and is easily removed for cleaning or maintenance.

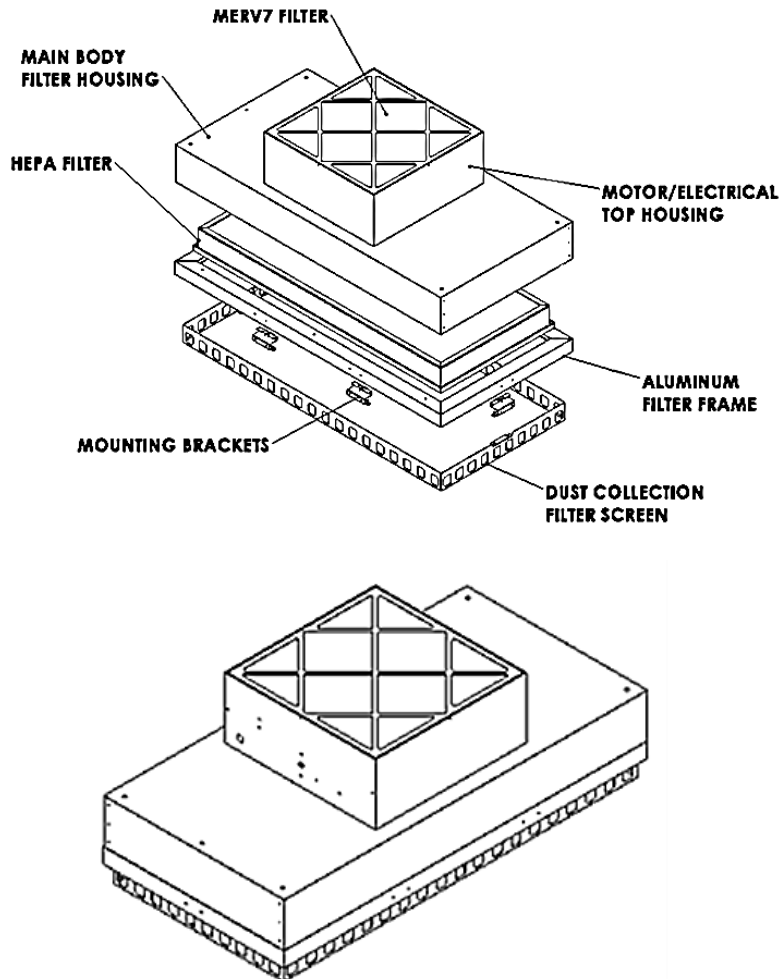

Figure 3: WhisperFlow® Reverse-Flow FFU



WhisperFlow® Fan Filter Units

REVERSE AIR-FLOW WHISPERFLOW® PERFORMANCE DATA			
Nominal Unit Size (ft.)	Filter	Sound (dB) @90FPM	AIR FLOW (CFM) @ Max. Speed
2' x 2'	HEPA (RSR)	60	387 CFM
2' x 4'	HEPA (RSR)	60	353 CFM

REVERSE AIR-FLOW WHISPERFLOW® ELECTRICAL DATA						
Nominal Unit Size (ft.)	Filter	Motor HP	Voltage	Full Load Amps	Frequency (Hz)	Power Consumption (Watts)
2' x 2'	HEPA	¼	115V	1.35	60	160
2' x 2'	HEPA	¼	230V	0.66	50/60	125/170
2' x 4'	HEPA	¼	115V	1.35	60	160
2' x 4'	HEPA	¼	230V	0.66	50/60	125/170

PRODUCT DIMENSIONS					
Nominal Unit Size (ft.)	Active Filter Area (sq.ft)	W (in)	L (in)	H (in)	Weight (lbs.)
2' x 2' (RSR)	2.2'	23.625"	23.625"	17.975"	40
2' x 4' (RSR)	5.2'	47.625"	23.625"	17.975"	60



WhisperFlow® Fan Filter Units

3.4 WhisperFlow® Smart® FFU with EC Motor

The Smart® WhisperFlow® has an electronically commutated (EC) brushless motor that allows for quiet, energy-efficient operation and infinitely variable speed control. The wide range is ideal for applications involving high static pressure. This unit includes an internal microprocessor that can be incorporated into Building Management Systems (BMS) to allow remote monitoring and control. FFU includes MODBUS® networking control card with closed-loop control capability that supports air pressure, air flow, and particle count sensors. The motor control panel includes diagnostic indicator lights, manual speed adjustment, test probe jacks, CAT5e ports, control mode switch and MODBUS® address DIP switch bank. The EC motor offers high performance, low energy consumption and low noise levels (40 dB) with forward-curved centrifugal fans. These units comply with Title 24 and ErP 2015 Directive.

The EC motor Control Card can be equipped with a 3/8"-diameter challenge port, which can be used to take differential pressure measurements to monitor filter performance or insert aerosols for leak-test certification. Port is capped when not in use.

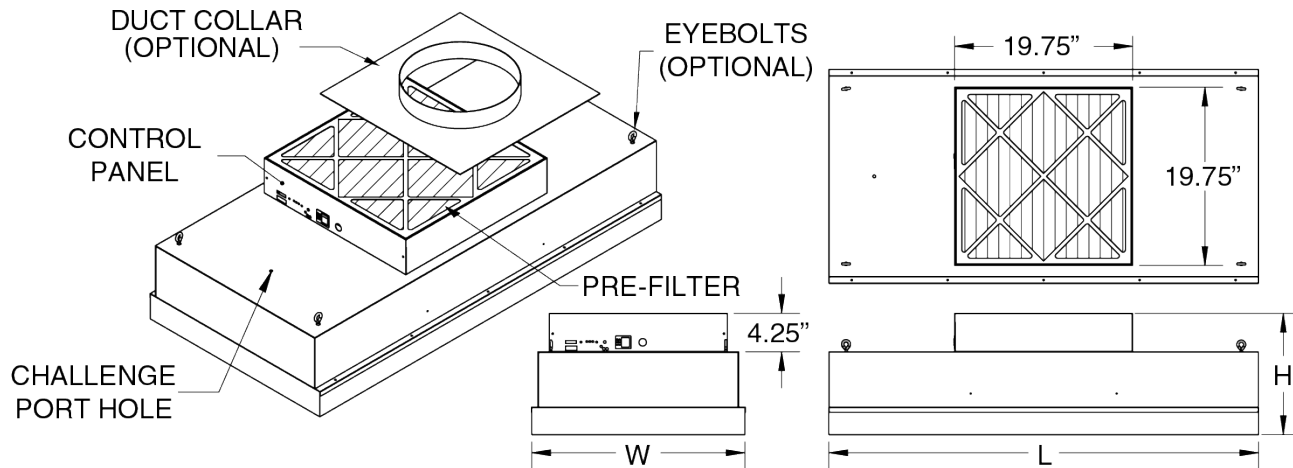

PRODUCT DIMENSIONS

Nominal Unit Size (ft.)	Active Filter Area (sq. ft.)	W (in)	L (in)	H (in)	Weight (lbs.)
2' x 4'	7.2'	23.63"	47.56"	12.60"	71
2' x 4' (RSR)	5.2'	23.63"	47.63"	14.66"	71
2' x 3'	5.3'	23.63"	35.56"	12.60"	53
2' x 3' (RSR)	3.7'	23.63"	35.63"	14.66"	53
2' x 2'	3.4'	23.63"	23.56"	12.60"	44
2' x 2' (RSR)	2.2'	23.63"	23.63"	14.66"	44

PERFORMANCE DATA

Nominal Unit Size (ft.)	Filter	Max CFM	Watts @ Max CFM	Watts @ 90 FPM	Sound (dB.) @ 90 FPM
2' x 4'	HEPA	900	350	180	40
2' x 4'	HEPA (RSR)	900	350	170	40
2' x 3'	HEPA	780	325	110	40
2' x 3'	HEPA (RSR)	780	325	80	40
2' x 2'	HEPA	475	225	100	40
2' x 2'	HEPA (RSR)	400	130	70	40



3.4.1 120V Configuration (default)

1. **Black** and **Red** wires are connected to the lower terminal.
2. Yellow Jumper Cable is installed.

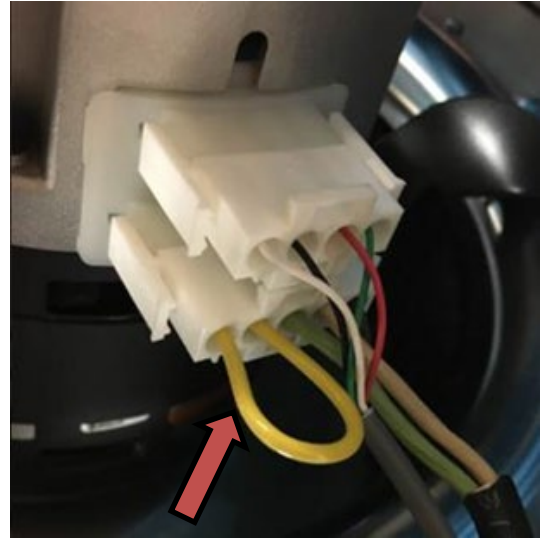
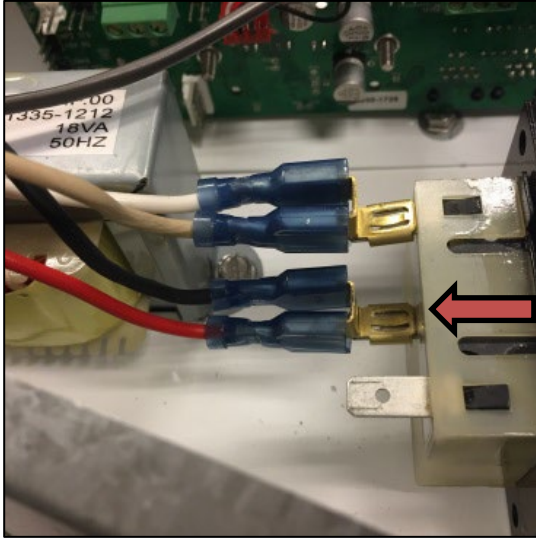

Figure 4: Backside view of 120V Configuration

3.4.2 220V Configuration

1. **Black** and **Red** wires connect to the upper terminal as shown.
2. Yellow Jumper Cable is removed.

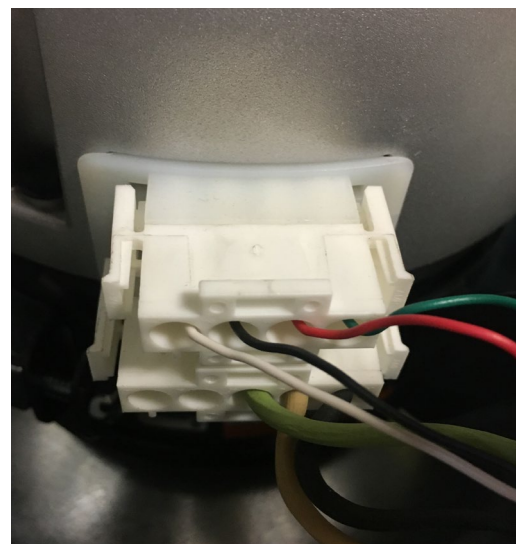
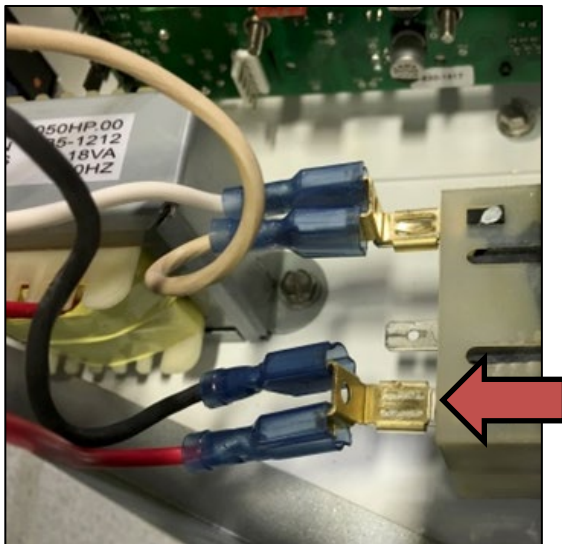

Figure 5: Backside view of 220V Configuration



WhisperFlow® Fan Filter Units

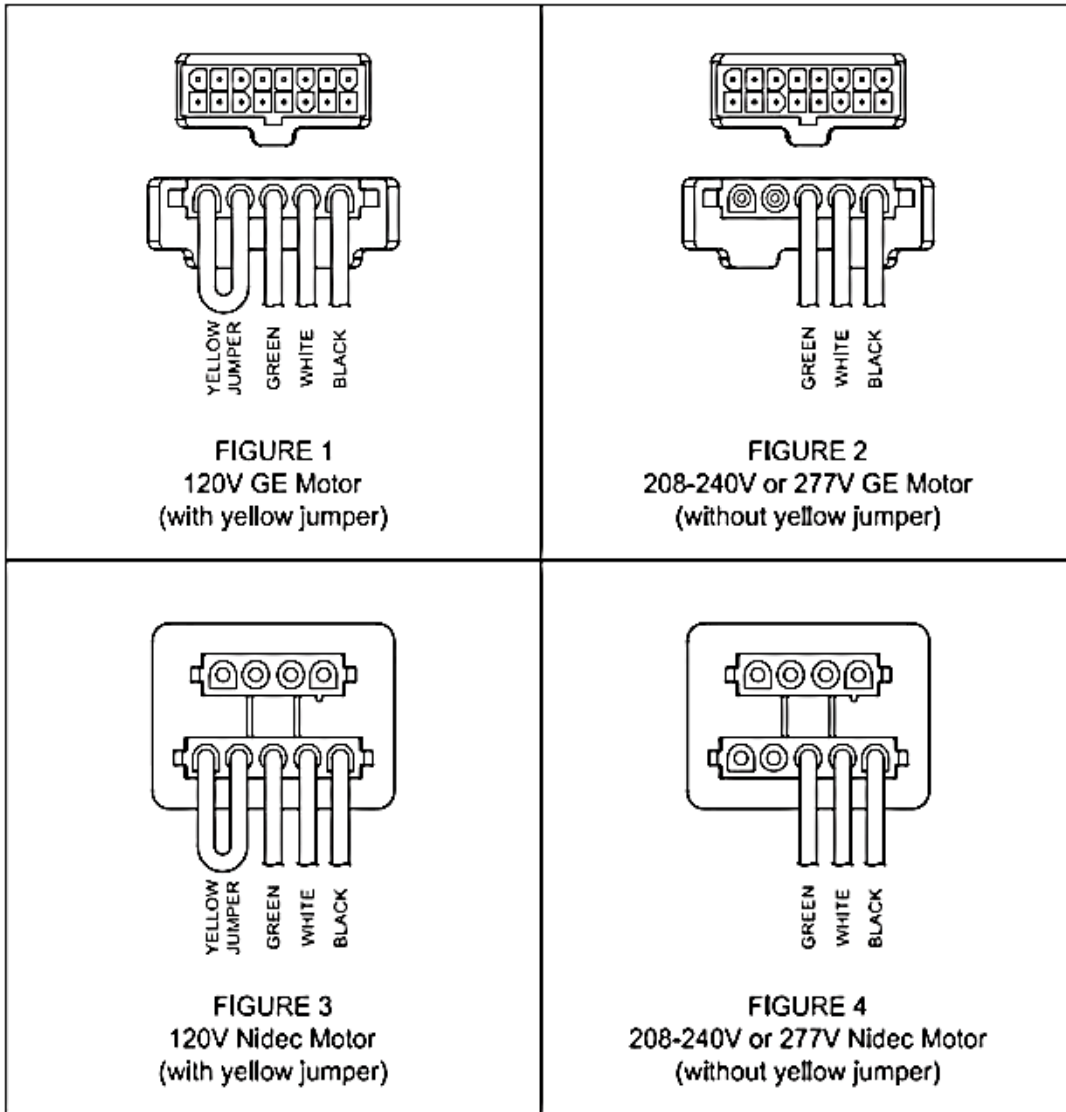

Figure 6: Motor Cable Configurations



3.4.3 EC Motor Control Card

The EC motor control card is a variable-speed controller designed for brushless DC (BLDC), electrically-commutated (EC) motors. The control card features industry standard MODBUS® networking, precision speed control (1-100%), and closed-loop control capability. The EC Motor Control panel provides access to LED diagnostics, manual speed adjustment, test probe jacks, CAT5e ports, the Control Mode DIP Switch, and the MODBUS® Address DIP Switch Bank.



Figure 7: EC fan filter unit control panel

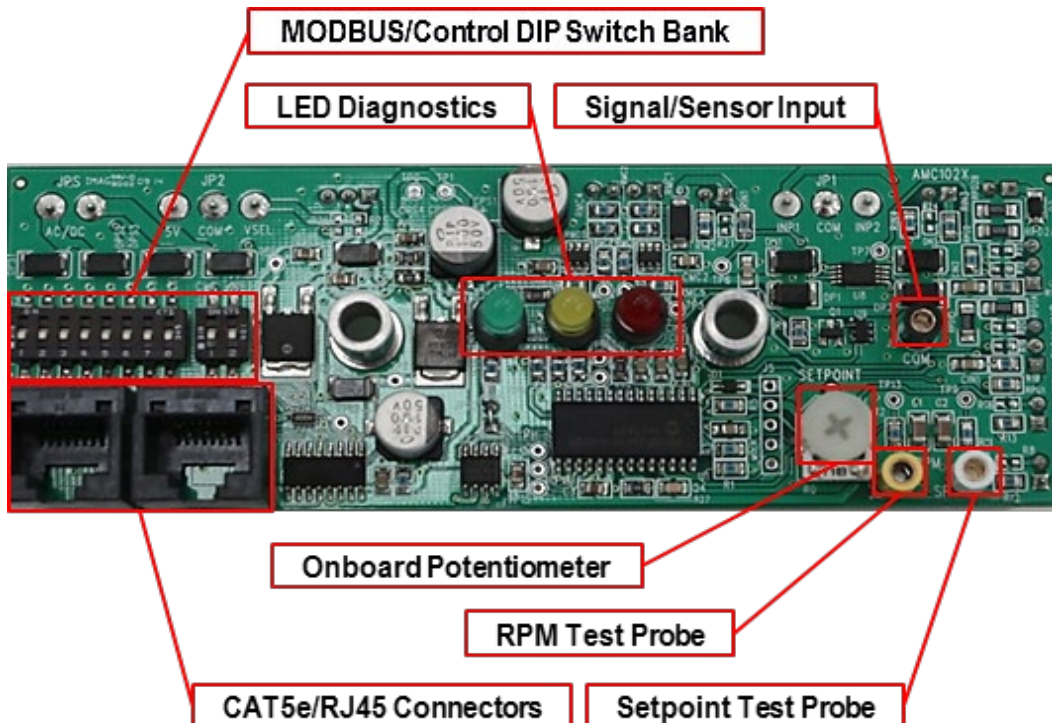



EC Motor Control Card Specifications:

- Operating Temperature: 0 – 40°C
- Open-frame PCB with standoffs; Panel-mounted
- 12-24V DC Power Supply (or network power)
- Two non-directional CAT5e/RJ45 connections for networking
- Motor Tachometer RPM Control

Analog Control Options:

- 5-10V from controlled voltage source
- 4-20mA signal from a sensor or potentiometer
- Internal Closed-Loop Control
- Manual Speed Adjustment

PWM Speed Command Signal:

- 10V, 80Hz

TACH Motor Speed Input:

- 10V @ 1mA needed switched to ground
- Maximum 5000 RPM measured
- Minimum 60 RPM measured

Industry Standard MODBUS® Networking:

- RTU Protocol
- RS485 9600,8,n,1

Control Modes

The EC Motor Control Card offers three different control modes for operating the FFU: MODBUS® RTU networking, 0-10 VDC analog control, or manual control through an onboard potentiometer.

Manual Control Mode:

The onboard potentiometer can be manually adjusted at the EC Motor Control Panel using a Philips-head screwdriver. Clockwise rotation increases the motor output, and counterclockwise rotation decreases the motor output.

Analog Control Mode:

Two terminals located on the EC Motor Control Card are designed to receive either a 0-10 VDC demand signal or 4-20mA sensor signal to regulate the motor output.

Network Control Mode:

Each EC Motor Control Card in a MODBUS® network must be assigned a unique address set in **binary format** using the eight DIP switches in the Address DIP Switch Bank.



WhisperFlow® Fan Filter Units

Test Probe Terminals

The test probe terminals are provided on the EC Motor Control Card to measure the motor RPM or check for a PWM signal using a multimeter.

Manual or Analog Control Modes:

To measure RPM, set the Address DIP Switches at a value greater than 1. The test probe jacks will output 0-2000 mVDC to represent motor RPM.

Example: 500 mVDC = 500 RPM

To measure demand signal, change the Address DIP Switches to the value of 0.

Note: Changing the address will not interrupt power to the Control Card.

Network Control Mode:

In the MODBUS® network control mode, the test probe terminals will always output 0-2000 mVDC to represent motor RPM.

Mod/BUS Control Mode DIP Switch Configurations		
		Manual Control Mode DIP Switch Bank S1: SWITCH #1 OFF SWITCH #2 OFF
		Analog Control Mode DIP Switch Bank S1: SWITCH #1 ON SWITCH #2 OFF
		Network Control Mode DIP Switch Bank S1: SWITCH #1 OFF SWITCH #2 ON
		Closed-Loop Feedback Network Control Mode DIP Switch Bank S1: SWITCH #1 ON SWITCH #2 ON
Example Addresses in Network Mode		
		MODBUS® Address Value = 1 DIP Switch Bank S2: SWITCH #1 ON
		MODBUS® Address Value = 21 DIP Switch Bank S2: SWITCHES #1,3,5 ON

Note: Address zero should not be used for Networked Control mode as it is reserved for global commands.

Note: The EC Motor Control Card must be power-cycled for any address changes to take effect.



WhisperFlow® Fan Filter Units

Control Card Electrical Specifications

Electrical Ratings	
Input Voltage, AC, 50/60Hz	12 – 28V ¹ AC
Input Voltage, DC	14 – 30V DC
Operating Current, AC	35 mA AC
Operating Current, DC	30 mA DC
Accessory Current 5V, 10V	50 ³ mA DC
Accessory Current V.RFU ²	100 ³ mA DC
¹ Refers to actual AC voltage values ² V.RFU is rectified and capacitive-filtered, but is unregulated ³ Maximum current values stated in support of a single connected load	

“Stand Alone Operation” Power Source Ratings	
Supply Transformer Voltage Rating,	12 – 24V AC
Supply Transformer Power Rating	2 VA
Regulated DC Supply Voltage Rating	14 – 30V DC
Regulated DC Supply Power Rating	2 W

Extended Accessory Output Currents for Stated Input Voltage Condition				
Input Voltage	Accessory Current, DC mA ²			Suggested AC/DC Source Power Rating
	5V	10V	V.RFU	VA
14V DC Regulated	300	300	500	20,20,30
30V DC Regulated	50	50	500	10,10,60
12V AC ¹ Transformer	100	100	100	5,5,5
28V AC ¹ Transformer	50	50	200	10,10,25
¹ AC voltage spec refers to actual AC voltage values , i.e., not transformer ratings, etc. ² Current values stated in support of a single connected load.				

Specifications	
Horsepower	1/3 HP
Voltage	120/240V, 50/60Hz
Speeds	300 – 1250 RPM
Inputs	2 Way Serial Communication & PWM
Frame	NEMA® 48
Enclosure	Continuous Air Over
Mounting	Belly Band
Amperage	4.2/2.7 Amps



4. Filter Cleaning and Replacement

The HEPA filter installed inside the FFU cannot be cleaned and will typically last for at least a few years depending on several factors such as ambient conditions, total operating time, fan speed setting (airflow rate), and maintenance of the pre-filters. When the unit is used in an ISO-classified environment, the HEPA filter will often perform sufficiently for a much longer period of time.

However, if air speed is significantly reduced or the HEPA filter fails to pass certification by an independent certifier, the HEPA filter may need to be replaced. Be sure to verify the proper operation of all other components in the system before attempting to replace the HEPA filter. A filter replacement alarm system is available to issue a warning alarm when pressure reaches twice the initial backpressure; system includes an audible buzzer with silencer that sounds when set point level is exceeded.

4.1 When Should I Change My Filter?

Filter replacement is not time dependent, but performance dependent. The filter should be changed when the fan filter unit can no longer achieve any of the required conditions such as: particle count, face velocity, room air change rate, and/or room pressure differential.

The scheduled maintenance of the unit depends on the installed location and consists of changing the pre-filter and the HEPA filter. It is recommended that the pre-filter be inspected and cleaned every three months or sooner depending on the cleanliness of the external environment. Replace the HEPA filter if any of the following apply: your maintenance program calls for it, filter integrity is compromised, face velocity falls below acceptable levels, pressure drop across the filter has doubled since install, or the filter has reached 5 years of use or 10 years of age.

[Filter Replacement Alarms](#) provide automatic replacement alerts to avoid costly and unexpected operational interruptions. Simply adjust the pressure set-point to adjust the frequency of filter alerts for replacement. Terra Universal provides a wide selection of cleanroom-appropriate instruments including gauges, particulate monitoring systems, and fan filter packages with automatic replacement alarms.



4.2 Top-Side Filter Replacement

Topside replaceable FFUs require the units to be removed from the cleanroom ceiling or hood for filter replacement. This replacement may require shutting down the cleanroom operation.

1. Disconnect the fan/filter unit from the PDM.
2. Attach double stick tape to a polypropylene panel – place on all four sides. The panel protects the HEPA filter from damage (See Figure 11).
3. Place the polypropylene panel over the filter screen, making sure that it only adheres to the screen without overlapping the edges (See Figure 12).
4. Push one side of the FFU up (See Figure 13), rotate it 90° (See Figures 15 and 16) and lower through the ceiling grid.
5. Place the unit on a flat work surface and remove the 10 sheet metal screws that hold the HEPA/ULPA filter to the case (See Figure 17).
6. Replace with a new HEPA/ULPA filter carefully handling edges only.
7. Secure filter to the case with the same screws used previously.
8. Place unit back onto the ceiling grid.



Figure 11: Polypropylene panel with tape



Figure 12: Panel attaching to exposed HEPA filter



Figure 13: Panel fully attached to filter screen without overlapping edges



Figure 14: FFU pushed up on one side for removal



Figure 15: Personnel rotating FFU to remove from ceiling grid



Figure 16: FFU rotated 90° and lowered completely from ceiling grid

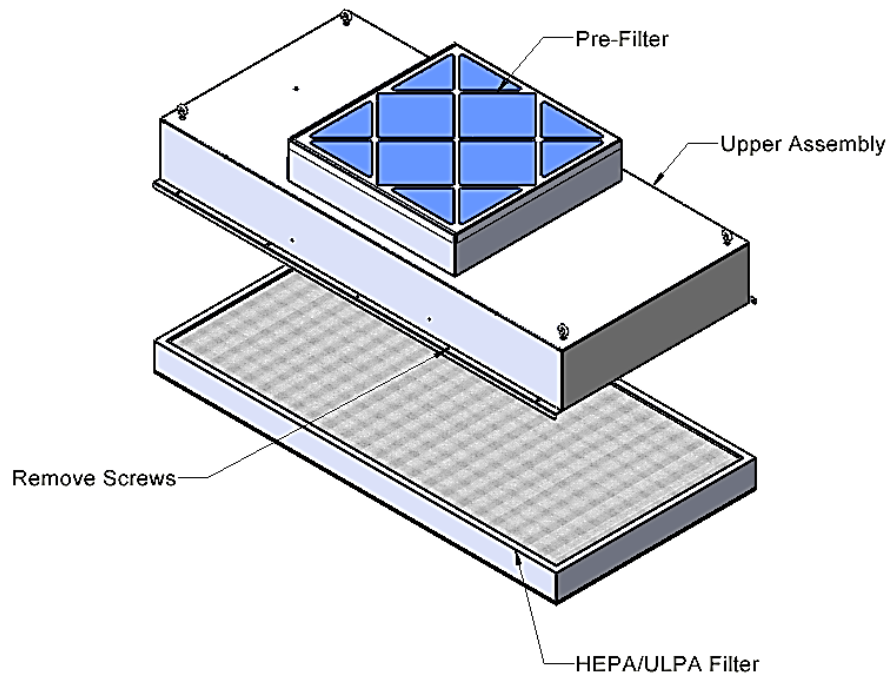

Figure 17: Diagram of FFU assembly



4.3 Room-Side Gel Seal Filter Replacement (BIBO compatible)



WARNING:

For applications involving risk of exposure to harmful particulates or pathogens in the filter media, use appropriate PPE and reference your facility's protocol for safe removal and disposal of filters.

The Room-Side Replaceable (RSR) FFU is designed so that the HEPA or ULPA filter can be replaced from inside the cleanroom without breaching the controlled environment. The filter assembly is separate from the fan module, which stays in place in the ceiling grid.

RSR FFU filters use gel seals. Gel-seal filters ensure that air flows directly through the fan filter media rather than around it. Terra gel seal FFUs feature a fire retardant, phosphorous-free polyurethane gel-sealant to seat against a knife-edge on the fan housing. The seals for RSR filters combine two different edge materials. The first is a track channel that contains the gel seal. The other side of the seal is a "knife-edge" that penetrates the gel and seals the enclosure.

DO NOT TOUCH the gel and do not allow the gel to collect dirt, dust, grease, or oil. Be vigilant of debris or glue fragments in the corners of the unit, as these areas are most susceptible to collecting and retaining residues, contaminants, and material fragments.

DO NOT TOUCH the upstream side of the HEPA or ULPA filter.

Step 1: Remove the Existing HEPA or ULPA Filter

1. First, you must remove the stainless steel screen covering the filter that is held in place with friction catches (See Figure 8). This screen protects the filter from damage and enhances airflow uniformity.
2. Next, rotate the metal tabs that help hold the HEPA filter in place (See Figure 9).
3. Gently let the used filter drop down, and set aside for disposal.
4. The filter assembly is surrounded by a channel containing a gel seal. If the gel seal does not release, gently pull down on the HEPA or ULPA filter to release the seal, then lower the filter straight down through the housing.
5. After removing the filter, ensure the fan filter unit knife edges are free and clear of any debris. Wipe any residual gel from the knife-edge to prepare for the replacement filter.

Step 2: Install the new HEPA or ULPA Filter

The following steps will require assistance from another person to help center and secure the new filter.

1. Inspect the gel seal of the filter being inserted, to ensure adequate gel material is present and within 1/16" from the top of the gel track.
2. Before inserting the filter, ensure the frame is flat, level, and centered to the housing with equal clearance between the filter and the housing on all four sides.
3. Position your new filter carefully before pushing into place; the knife-edge of the fan module should be centered in the channel (equal amounts of gel on both sides). Figure 10 shows the gel-filled channel of the RSR filter.
4. Lift the filter by the frame with one person on each end. Carefully lift the fan filter in unison.
5. DO NOT LET GO OF THE FILTER UNTIL SECURED:
6. Hold the filter in place while the second person tightens the filter clamps.
7. To secure the filter clamps, rotate the (4) filter clamps back to the original position, then tighten hand tighten with an appropriately sized wrench.
8. Reinstall the stainless steel screen by pushing up on the friction catches until the screen clicks into place.
9. To replace the pre-filter located at the top of the fan module, slide the old filter out of the two tracks holding it in place on top of the FFU and then slide in the new pre-filter.
10. HAND TIGHTEN ONLY. DO NOT OVERTIGHTEN.



Figure 18: Friction catches hold the screen to the fan module housing



Figure 19: Filter-face grille's metal tabs

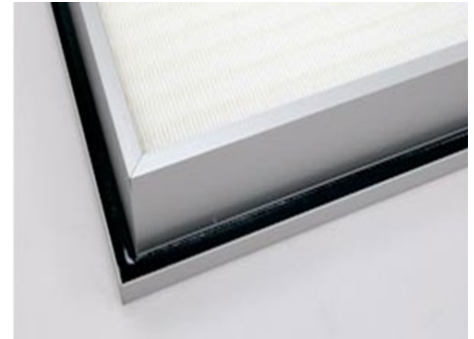
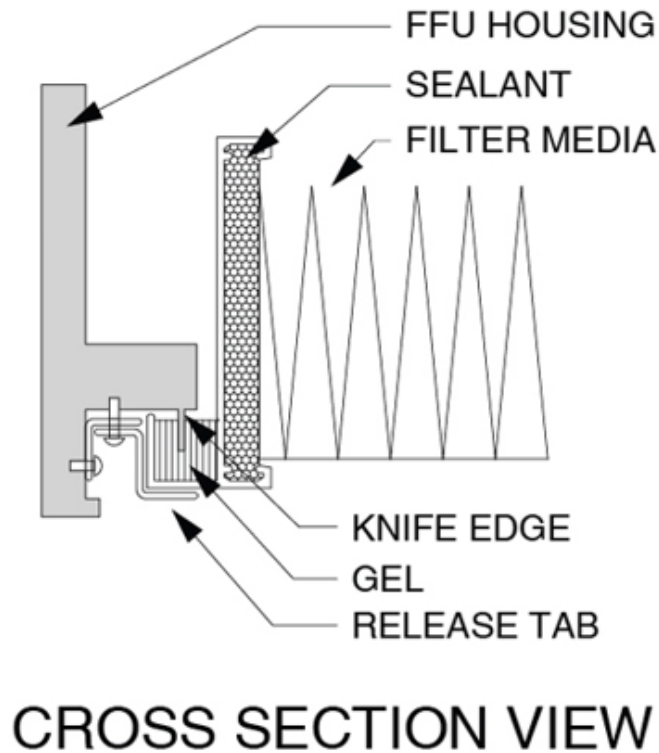

Figure 20: Gel-filled channel of RSR filter





4.3.1 Gel Seal Filter Damage Inspection

It is important to inspect the gel seal and handle it with care to avoid damage during installation. Damage can occur for numerous reasons including age, chemical exposure, excessive penetration, shearing, or tearing caused by removing the knife-edge too quickly from the gel channel. All Terra filters should be visually inspected for freight damage before installation.

Gel Seal Chemical Damage

Chemical damage is categorized into two groups; mild and severe. Chemical damage can occur to the gel seal when exposed to internal or external substances, or as the result of environmental conditions:

- Reversion (degradation or liquefaction) of the gel into a liquid state.
- Chemical attack, typically caused by oxidizing cleaning agents, may incur a loss of surface tack, blisters, or skin formulation on the surface of the gel.
- Ultraviolet (UV) light degradation may cause the gel surface to craze, crack, or liquify.
- Thermal degradation results in a loss of elasticity and surface tack that results in a gel that becomes hard and less malleable.

Mild Chemical Damage

Mild chemical damage results in slight changes to the physical characteristics of the gel, but are not considered severe enough to damage the fit and function of the gel seal including:

- Change or loss of color that does not have any measurable effect on the elasticity or hardness of the gel.
- Formation of a slight exterior skin on the surface of the gel that is only noticeable when the gel is "pinched" between the fingers.
- Minor reduction in surface tackiness

Filters that exhibit only mild signs of chemical damage are likely to continue to seal and perform without issue.

Severe Chemical Damage

Severe chemical damage occurs when chemical substances cause major and significant changes in gels' physical characteristics.

- Significant changes in hardness or elasticity
- Complete loss of surface tack
- Formation of thick skin on gel surface layer
- Formation of wet areas on the gel, or liquefaction that results in gel drip.

If gel seal filter leaks are detected upon installation, remove the filter and replace it with a new one before reinstalling and testing.



Gel Seal Physical Damage

Physical damage to the gel seals or HEPA/ULPA media are the most common archetypes for filter damage. Because damage can occur at any stage of the storage, handling, shipping, and installation phase, all filters and gel seals should be visually inspected for freight damage before installation.

Damage to the filter media or gel seal can range from very mild to unrecoverable. The most common form of physical damage is caused by removing the knife edge from the gel too quickly.

The most common causes of gel seal filter damage include:

- The knife-edge is removed too quickly from the gel, which causes shearing.
- Knife edge is inserted too deeply into the gel channel, which can cause the gel to split in half and compromise the seal. The maximum recommended penetration of the knife-edge should be no greater than 70% of the inside channel gel width.
- Abrasion caused by friction between the gel seal and the housing, tools, packaging material, or hands
- Packaging materials such as films and plastics readily stick to gel materials; this may cause damage if hastily removed while in contact with the gel.
- Knife edge seal is too sharp, which can cause over-penetration of the gel.

Mild Physical Damage

Mild physical damage is considered superficial and will not interfere with the proper sealing of the fan filter unit. Lines, ripples, and rough spots that penetrate the gel no further than 0.25 inches (6 mm) are not expected to compromise the fit and function of the gel seal.

Filters that exhibit only mild signs of chemical damage are likely to continue to seal and perform without issue.

Severe Physical Damage

Severe damage occurs when tears, flaws, or cuts penetrate beyond the first 0.25 inches of the gel seal. The most common causes of severe damage include:

- Shearing occurs when the knife edge is removed too quickly from the gel.
- The knife edge is too sharp and cuts through the gel seal.

Gel seals with severe physical damage will have a higher probability of failure.



WhisperFlow® Fan Filter Units

Gel Seal Housing and Cross Section

The below figures illustrate examples of gel seals that incurred shearing or cut-throughs. In both scenarios, there is a high probability that the seal is compromised and will require replacement.

The ideal outcome for gel filters is for them to be carefully removed and reinstalled on one or more instances. When installed with care, gel seals will accommodate multiple re-installations. If necessary, a scan test can verify and confirm the integrity of the filter and seal system upon re-installation.

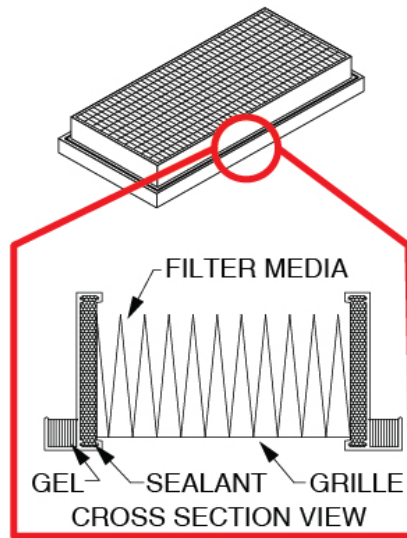

Nearly new condition gel with the knife edge removed once.

If the filter is found to be leaking at the gel seal during the test, the filter should be removed and the filter should be replaced prior to re-installation and testing.

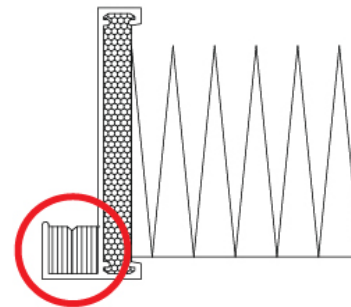

Gel Experiencing multiple but careful knife edge removal and re-installation.

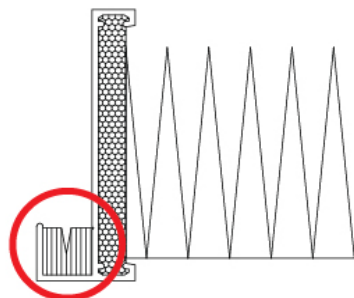

Gel that was cut by a too sharp knife edge and one that was also inserted too deeply.

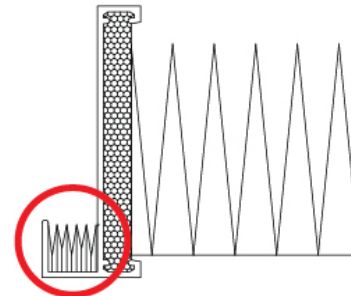

Gel that was subject to too rapid removal of the knife edge numerous times.



WhisperFlow® Fan Filter Units

5. Wiring Diagrams

- Smart®WhisperFlow®
- WhisperFlow®

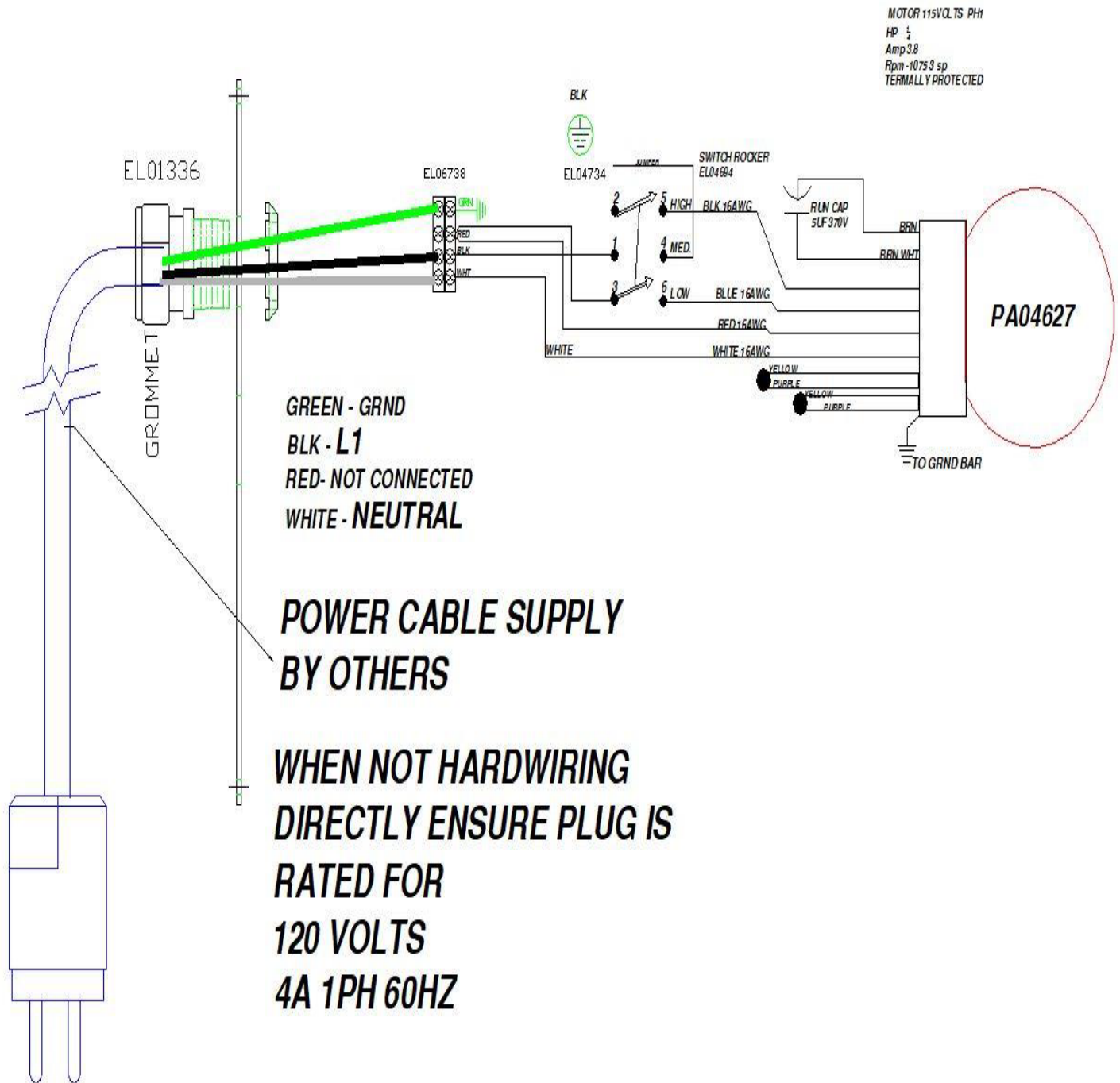



WhisperFlow® Fan Filter Units

MOTOR 115VOLTS PH1
HP 1/4
Amp 3.8
Rpm -1075/3 sp
TERMALLY PROTECTED

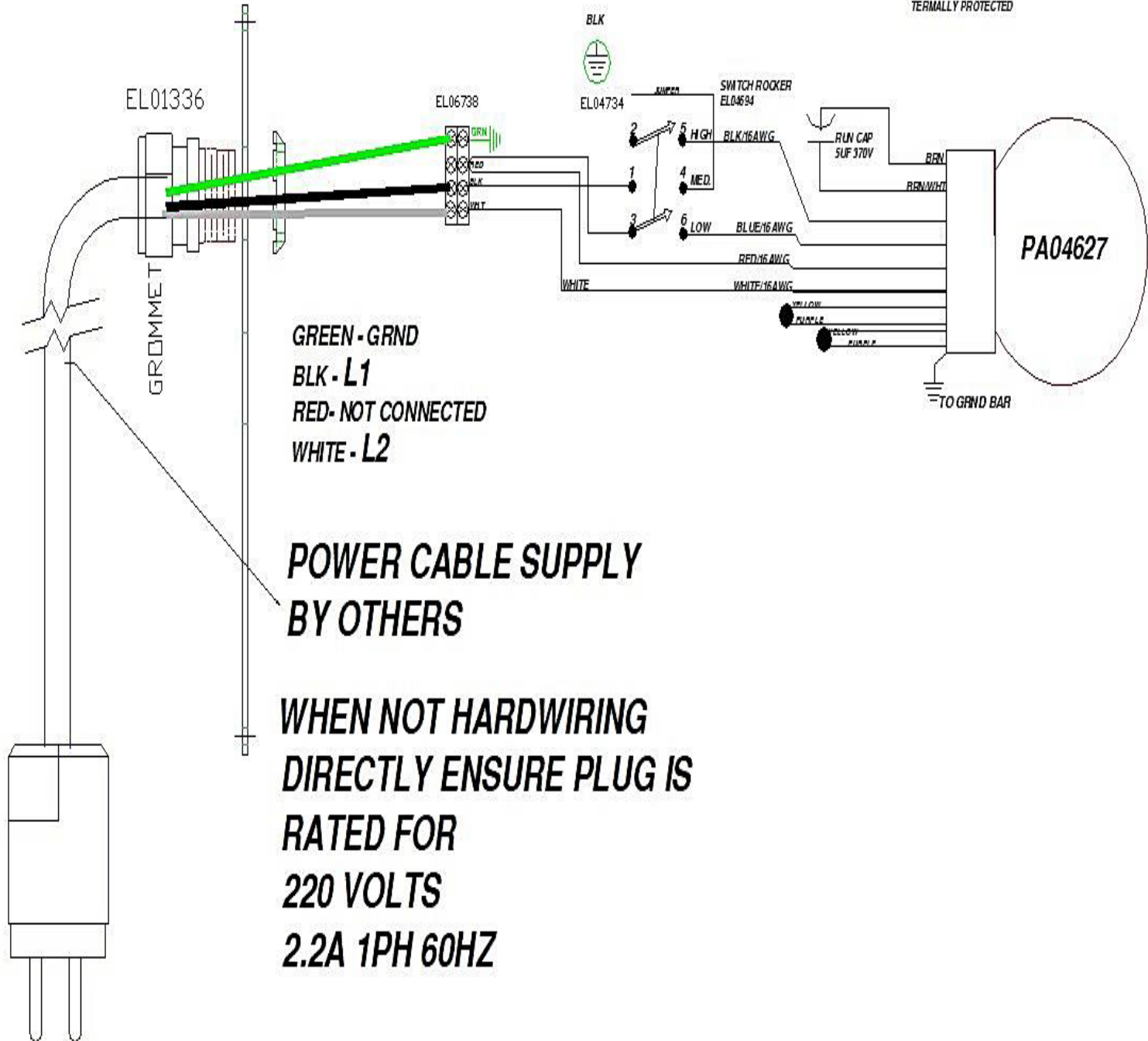



6. Speed Configuration with Power Distribution Module (PDM)

The electric circuit design of the PDM limits speed configurations of FFU's with PSC motors. All FFU's with PSC motors should be switched to MEDIUM or HIGH speed setting when connected to a PDM. Thermal overload can occur when one FFU is set to LOW, and the others are set to MEDIUM or HIGH speed settings. The FFU motor set to LOW can draw excess current from the PDM which can lead to thermal overload on the motor, motor failure, and/or electrical hazards.

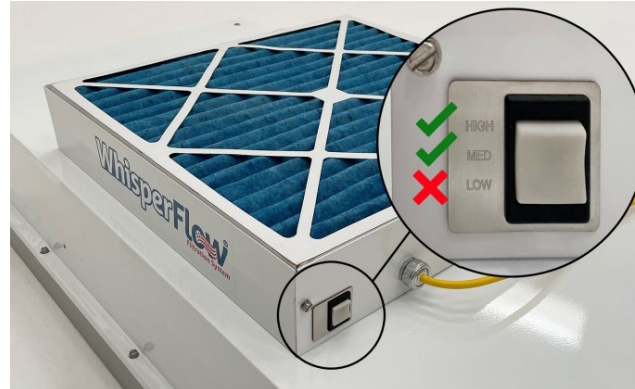

NOTES:

- Setting all FFU's with PSC motors to LOW does not cause an immediate problem. However, it is not advised as there is a risk of accidentally adjusting one FFU's speed setting to HIGH or MEDIUM, which could lead to thermal overload on a FFU motor that is still on LOW speed.
- "Night service" mode from the control panel is unaffected and operates correctly when all individual FFU's are switched to HIGH or MEDIUM speed settings.
- This limitation does not apply if the FFU with PSC motor is used individually without a PDM, and powered directly from a standard wall outlet.
- This limitation does not apply to Smart® FFU's with Electronically Commutated (EC) motors. Smart® FFU's do not use PSC motors.

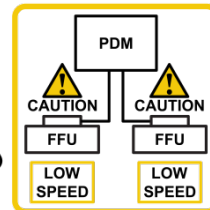
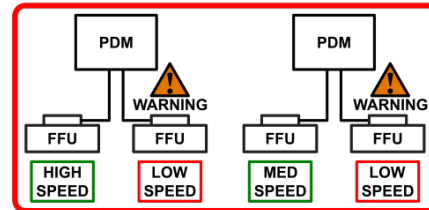
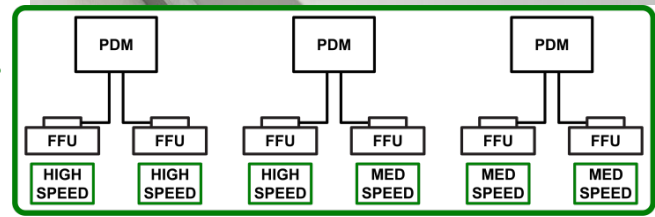



6.1 How to Connect Low Mode for Standalone Fan Filter Units

- FFUs default to night mode for use in our cleanrooms
- To enable low air flow setting on a standalone 3-speed FFU (non-EC motor), perform the following instruction;



Figure 21. Overall picture of FFU



Figure 22. Red wire comes disconnected

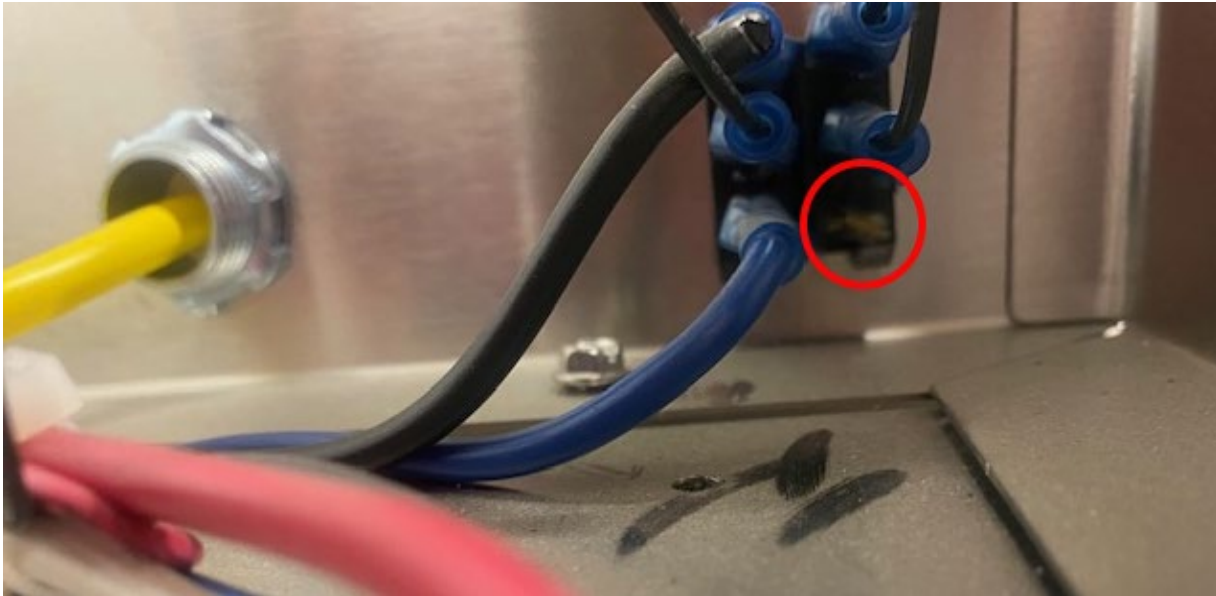

Figure 23. Take red cable and insert into empty slot on connector

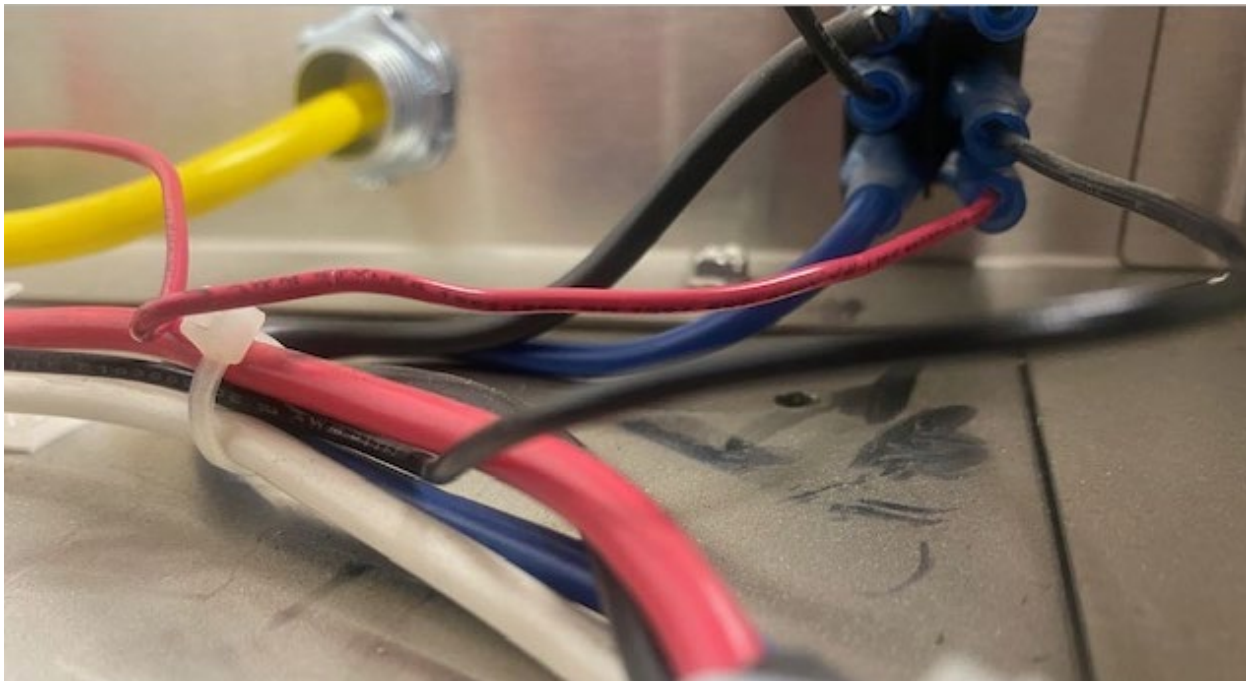

Figure 24. Low mode is activated



7. Testing

WhisperFlow® fan filter units are thoroughly tested at the factory before shipment. However, because of the “rigors” of shipping, Terra Universal encourages re-test after installation.

Terra Universal recommends that the customer contact an independent organization, with technicians trained and experienced in performance evaluation and maintenance of clean air equipment.

All filters are tested with properly calibrated equipment to IEST-RP-00034 and all filters are UL 900 recognized. If your filters have special requirements, please see original engineering specifications for your specific project.

8. Troubleshooting

Low Air Velocity

1. Check the prefilter; clean or replace if dirty.
2. Adjust the fan speed to a higher output.
3. Verify the power output for voltage, amperage, and distribution frequency
4. Replace HEPA/ULPA filter if air velocity does not change.

High Air Velocity

1. Adjust the fan speed to a lower output.

Non-Laminar Flow and/or Excessive Contamination

1. Verify that no obstructions are upstream of airflow pattern.
2. Ensure that no other air-moving devices are operating in or around cleanroom which disrupt room’s airflow pattern.
3. Confirm the air velocity is properly working, and, if low, follow the “Low Air Velocity” procedure.
4. Run a smoke and photometer test on HEPA filter. Seal or replace HEPA filter if needed.

Contact Technical Support at:
Terra Universal Inc.
714-578-6100

9. Replacement Parts

Replacement parts apply for the following models:

- Standard WhisperFlow®
- Smart® WhisperFlow® EC (Electronically Commutated) Motor
- Narrow WhisperFlow®,
- WhisperFlow® Reverse-Flow
- Ducted Filter Module WhisperFlow®

Please contact us for information on replacement parts. Some replacement parts may differ across generations of some models. Provide sales associate with pertinent information, such as serial number, model number and date, for replacement parts or a new FFU. Information located on the FFU label on the lower part of the assembly.

Order Number _____
 Serial Number _____
 Unit Model Number _____
 Date _____



WhisperFlow® Fan Filter Units

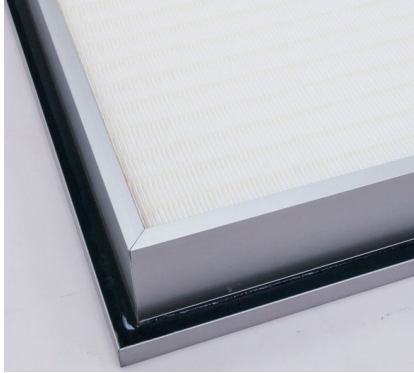

Room-side Replaceable Filters			
Nominal Unit Size (ft.)	Filter	Frame Material	Part Number
2' x 4' (RSR)	HEPA	Aluminum	6601-25-R
2' x 3' (RSR)	HEPA	Aluminum	6601-26-R
2' x 2' (RSR)	HEPA	Aluminum	6601-27-R
2' x 4' (RSR)	ULPA	Aluminum	6601-28-R
2' x 3' (RSR)	ULPA	Aluminum	6601-29-R
2' x 2' (RSR)	ULPA	Aluminum	6601-30-R

Top Side Replaceable Filters			
Nominal Unit Size (ft.)	Filter	Frame Material	Part Number
2' x 4' (Top Side Replaceable)	HEPA	Aluminum	6601-25
2' x 3' (Top Side Replaceable)	HEPA	Aluminum	6601-26
2' x 2' (Top Side Replaceable)	HEPA	Aluminum	6601-27
2' x 4' (Top Side Replaceable)	ULPA	Aluminum	6601-28
2' x 3' (Top Side Replaceable)	ULPA	Aluminum	6601-29
2' x 2' (Top Side Replaceable)	ULPA	Aluminum	6601-30

10. Accessories



Ionizing Bar		
Length	Voltage	Part Number
44"	240 V	2005-49-220
44"	120 V	2005-49
33"	240 V	2005-48-220
33"	120 V	2005-48
22"	240 V	2005-47-220
22"	120 V	2005-47



Challenge Port Kit	6601-99
---------------------------	---------



WhisperFlow® Fan Filter Units



Power Distribution Modules (PDM's)		
PDM Type	Voltage	Part Number
Primary	120 V	6600-29B-T
Secondary	240 V	6600-29B-S-220
Secondary	120 V	6600-29B-S
Primary	240 V	6600-29B-P-220
Primary	120 V	6600-29B-P
Booster	240 V	6600-29B-B-220
Booster	120 V	6600-29B-B
Wireless Control, Primary	240 V	6600-29A-WL-P-220
Wireless Control, Primary	120 V	6600-29A-WL-P
Power Outlet	240 V	6600-27-220
Power Outlet	120 V	6600-27

Power Cord Adapter	6601-13
---------------------------	---------



Filter Replacement Alarm	2625-54B-SS
---------------------------------	-------------

Note: PDMs require a control panel

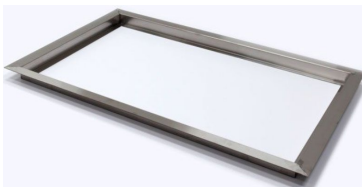

Eyebolt Package	6601-02
------------------------	---------

Mounting Frames		
Material	Size	Part Number
Stainless Steel	2'x4'	6604-02
Stainless Steel	2'x3'	6604-01
Stainless Steel	2'x2'	6604-00

11. Warranty

For more information about our warranty system, please visit our [company's warranty website](#).

*Thank you for ordering from
Terra Universal!*