

# WhisperFlow® Fan Filter Units

© Copyright 2026 Terra Universal Inc. All rights reserved • Revised May 2026



## Your Comprehensive Equipment Source





<b>1.</b>	<b>General Information</b> .....	<b>3</b>
	1.1 Part Numbers Covered by this Manual .....	4
<b>2.</b>	<b>Safety</b> .....	<b>5</b>
<b>3.</b>	<b>Start-Up</b> .....	<b>6</b>
	3.1 Installation .....	6
	3.2 WhisperFlow® FFUs.....	7
	3.3 WhisperFlow® Reverse Airflow FFUs.....	9
	3.4 WhisperFlow® Smart® FFU with EC Motor.....	11
	3.4.1.....	120V Configuration (default) 12
	3.4.2.....	220V Configuration 12
	3.4.3.....	EC Motor Control Card 14
<b>4.</b>	<b>Filter Cleaning and Replacement</b> .....	<b>18</b>
	4.1 When Should I Change My Filter? .....	18
	4.2 Top-Side Filter Replacement .....	19
	4.3 Room-Side Gel Seal Filter Replacement (BIBO compatible).....	21
	4.3.1.....	Gel Seal Filter Damage Inspection 23
	4.4 WhisperFlow® Portable FFU Filter Replacement (6601-66).....	26
<b>5.</b>	<b>Wiring Diagrams</b> .....	<b>30</b>
<b>6.</b>	<b>Speed Configuration with Power Distribution Module (PDM)</b> .....	<b>32</b>
	6.1 How to Connect Low Mode for Standalone Fan Filter Units .....	33
<b>7.</b>	<b>Testing</b> .....	<b>35</b>
<b>8.</b>	<b>Troubleshooting</b> .....	<b>35</b>
<b>9.</b>	<b>Replacement Parts</b> .....	<b>35</b>
<b>10.</b>	<b>Accessories</b> .....	<b>36</b>
<b>11.</b>	<b>Warranty</b> .....	<b>38</b>



## 1. General Information

This manual documents the operational guidelines for Terra Universal's WhisperFlow® Standard, Smart® EC (Electronically Commutated) Motor, Narrow, Reverse-Flow, Smart® Reverse-Flow fan filter units, and WhisperFlow® Portable fan filter units.

FFUs have several applications. They are most commonly used for laminar flow hoods, and in cleanrooms. For cleanrooms, FFU's are compatible with [Terra's Control Panels and Power Distribution Modules](#) (PDMs). PDMs and control panels are specifically designed to simplify electrical connections, reduce headaches, and get cleanroom projects completed faster. No hardwiring is required to connect and provide power to the fan filters, lights, and duplex PDMs. Not only are these systems much faster and easier to connect, but they also reduce the complexity and frequency of electrical touchpoints that can lead to human error.





## 1.1 Part Numbers Covered by this Manual

Fan Filter Unit Models			
<a href="#">WhisperFlow® Room-Side Replaceable</a>	<a href="#">WhisperFlow® Standard</a>	<a href="#">WhisperFlow® Smart®</a>	<a href="#">WhisperFlow® Reverse-Flow</a>
6601-24A-UR-220	6601-24-U-220	6601-24B-UR-EC	6601-24-UVSS
6601-24A-UR	6601-24-U	6601-24B-HRSS-EC	6601-24-UVFSS
6601-24A-HRSS-220	6601-24-HSS	6601-24B-HR-EC	6601-24-UV-220-CE
6601-24A-HR-220	6601-24-H2	6601-24A-USS-EC	6601-24-UV-220
6601-24A-HR	6601-24-H-NC	6601-24A-U-EC	6601-24-UV
6601-24-URS-220	6601-24-H-CA	6601-24A-HSS-EC	6601-24-HVSS
6601-24-HRSS	6601-24-H-220	6601-24A-H2-EC	6601-24-HVF-220
6601-23A-UR-220	6601-24-H	6601-24A-H-EC-CA	6601-24-HVF
6601-23A-UR	6601-23-U-220-CE	6601-24A-H-EC	6601-24-HV-220-CE
6601-23A-HRSS-220	6601-23-U-220	6601-23B-URSS-EC	6601-24-HV-220
6601-23A-HRSS	6601-23-U	6601-23B-UR-EC	6601-24-HV
6601-23A-HR-220	6601-23-HSS	6601-23B-HR-EC	6601-23-UVSS
6601-23A-HR	6601-23-H2	6601-23A-USS-EC	6601-23-UVFSS
6601-22A-UR-220	6601-23-H-CA	6601-23A-U-EC	6601-23-UV-220-CE
6601-22A-UR	6601-23-H-220	6601-23A-HSS-EC	6601-23-UV
6601-22A-HRSS-220	6601-23-H	6601-23A-HRSS-EC	6601-23-HVF-220
6601-22A-HRSS	6601-22-U-220-CE	6601-23A-H-EC-CA	6601-23-HVF
6601-22A-HR-220	6601-22-U-220	6601-23A-H-EC	6601-23-HV-220-CE
6601-22A-HR	6601-22-U	6601-22B-URSS-EC	6601-23-HV-220
	6601-22-HSS-220	6601-22B-UR-EC	6601-23-HV
<a href="#">WhisperFlow® Narrow</a>	6601-22-HSS	6601-22B-HR-EC	6601-22-UVSS
6601-1648-H-220	6601-22-H-CA	6601-22A-USS-EC	6601-22-UVFSS
6601-1648-H	6601-22-H-220	6601-22A-U-EC	6601-22-UV-220-CE
6601-1636-HS	6601-22-H	6601-22A-H-EC-CA	6601-22-UV-220
6601-1636-H-220-CE		6601-22A-H-EC	6601-22-UV
6601-1636-H-220	<a href="#">Ducted Filtered Diffusers</a>		6601-22-HVF-220
6601-1636-H	6601-24-HDR	<a href="#">WhisperFlow® Smart® Reverse-Flow</a>	6601-22-HVF
6601-1624-HS-220	6601-24-HD	6601-24A-UVSS-EC	6601-22-HV-220-CE
6601-1624-HS	6601-23-HDR	6601-24A-HV-EC	6601-22-HV-220
6601-1624-H-220-CE	6601-23-HD	6601-23A-UVSS-EC	6601-22-HV
6601-1624-H-220	6601-22-HDR	6601-23A-HV-EC	6601-22B-HVR
6601-1624-H	6601-22-HD	6601-22A-UVSS-EC	6601-22B-HVR-220
		6601-22A-HV-EC	6601-24B-HVR
<a href="#">WhisperFlow® Portable</a>			6601-24B-HVR-220
6601-66A-SS			
6601-66A-BP-SS			
6601-66-SS-CW			
6601-66A-UV-SS			
6601-66A-C			
6601-66A			
6601-66-BP			
6601-66-UV			
6601-66A-HC			



## 2. Safety

<p><b>Proprietary Notice</b></p> <p>This manual pertains to proprietary devices manufactured by Terra Universal, Inc. Neither this document nor any portion of it may be reproduced in any way without prior written permission from Terra Universal.</p> <p>Terra Universal makes no warranties applying to information contained in this manual or its suitability for any implied or inferred purpose. Terra Universal shall not be held liable for any errors this manual contains or for any damages that result from its use.</p>	<p><b>Safety Notice</b></p> <p>A thorough familiarity with all operating guidelines is essential to safe operation of the product. Failure to observe safety precautions could result in poor performance, damage to the system, or serious bodily injury or death.</p> <p><b>⚠ CAUTION</b></p> <p>Cautions are used when failure to observe instructions could result in significant damage to equipment.</p> <p><b>⚠ WARNING</b></p> <p>Warnings are used when failure to observe instructions or precautions could result in injury or death.</p>
<p>The information presented here is subject to change without notice.</p>	

### To reduce the risk of fire, electric shock, or injury to persons, observe the following:

- Do not use this unit for anything other than the intended manner of the manufacturer. Contact the manufacturer for additional clarification.
- Before servicing the unit, or replacing a filter, switch power to OFF at the service panel and lock it to prevent accidental power activation. When the panel cannot be locked, securely fasten a prominent warning device, such as a tag, to the service panel.
- When the removal/disconnection of either filter is required due to service or component replacement, the replacements are to be remounted as previously installed.
- Qualified person(s) must install the unit and configure the electrical wiring adhering to all applicable codes and standards, which includes fire-rated construction. All metal components must be properly grounded.
- Do not damage or interfere with electrical wiring and other hidden utilities when cutting or drilling into the wall or ceiling.
- Check the ECM unit's supply cord for damage, if it is damaged it must be replaced by the manufacturer, its service agent, or similarly qualified persons to avoid a hazard.

### Critical Operation Conditions

- DO NOT TOUCH THE FILTER SURFACE WITH HANDS, TOOLS, OR OTHER OBJECTS.
- DO NOT STACK OR PLACE ANY ITEMS ON TOP OF THE FILTER UNITS.
- Filters are to be handled and lifted only by the frame to prevent damage to the HEPA or ULPA media.
- When in operation, ensure that all packaging materials are removed and that airflow is unrestricted.
- Call a certified electrician for any electrical project to avoid the risks of injury, fire hazards, code violations, or potential damage to your electrical system and components.
- The filter media is extremely sensitive and can damage easily. Avoid touching and damaging the HEPA filter because the warranty will void.
- Never place anything on the filter. Always place filter on its side to avoid damage.





## 3. Start-Up

### 3.1 Installation

The fan filter unit is designed to fit on top of a Terra Laminar Flow Hood or standard clean room ceiling grid. It includes 1/4-20 thread holes on corners for guy-wire suspension. Room-side replaceable filters are packaged separately for jobsite installation by others.

1. Remove all packaging material from the shipping box (Figure 1)
2. Perform a thorough visual inspection to ensure no damage has occurred during shipping. Check that there are no visible dents or penetrations on the filter face and grille. If damage is discovered, contact the freight company to file a damage claim immediately.
3. Remove the pre-filter and manually rotate the fan wheel to make sure it does not come in contact with any stationary parts and that there is no visible loose screws or bolts obstructing the wheel's rotation.
4. Verify unit is sanitary for cleanroom placement.
5. Optional: fasten the eyebolts into each corner of the lid assembly.
6. Lift the unit into the ceiling and position onto the ceiling grid. If the grid is not secured, fasten to an engineered support system with chain, s-hooks and eyehooks (usually supported with wires).
7. Confirm fan dimensions are aligned with grid dimensions.
8. Raise the unit and secure with support system method suspended from a structural support bracing.
  - a. Minimum clearance of 1 foot (including fixtures, ducts and pipes) on all sides and at least 2 feet of vertical clearance between the FFU inlet and ceiling for proper air supply.
9. Connect the 4-pin power plug to the unit, set the speed switch to the desired position (units are shipped from the factory with the speed switch set to medium), and turn on the external power switch. With power applied, the fan will rotate, and filtered air will exit the HEPA filter.

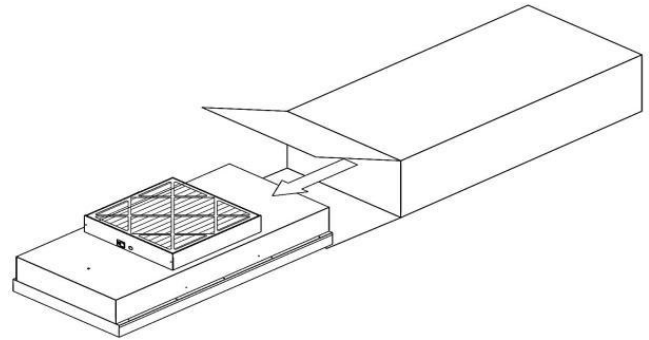

Figure 1: Unboxing

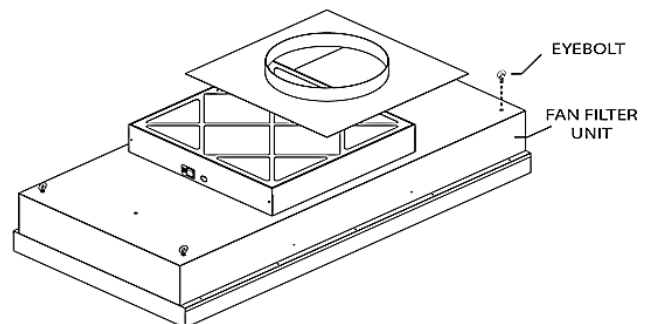

Figure 2: Hanger Supports



**To avoid thermal overload on FFU's with Permanent Split Capacitor (PSC) motors, do not use LOW speed switch when the FFU is connected to a PDM.**

#### WARNING

**Note:** After completing the Initial Setup, validation may be performed by a third-party testing service for HEPA filter integrity (leak-testing), Air Changes per Hour and particle counter measurements to verify ISO 5 particle levels. Third-party testing should take place within the intended cleanroom or another controlled environment to ensure an accurate evaluation of its performance.



## 3.2 WhisperFlow® FFUs

The WhisperFlow® fan filter unit has a 3-speed switch (low, medium, high) with a ¼ Hp permanent split capacitor motor. The internal baffling plate and diffuser panel provide quiet uniform air flow across the filter face. FFU includes permanently-lubricated bearings, factory balanced forward-curved blower wheel, ¼-20 thread holds on corners for guy-wire suspension, and a filter membrane constructed from micro-glass. FFU uses FDA-approved silicon sealant and a 30% ASHRAE rated MERV 7 pre-filter, 20" x 20" x 1". The unit uses standard UL 900 filters and is tested to IEST recommended standards. Room-side replaceable filter models feature fire retardant phosphorous free polyurethane gel-sealant to seat against a knife-edge on the fan housing and easy-open clips for fast filter replacement from the room side without breaching the cleanroom ceiling. The low profile design is ideal for cleanrooms with limited ceiling space.

There is challenge port fitting for a 3/8"-diameter challenge port, which can be used to take differential pressure measurements to monitor filter performance or insert aerosols for leak-test certification. Port is capped when not in use.

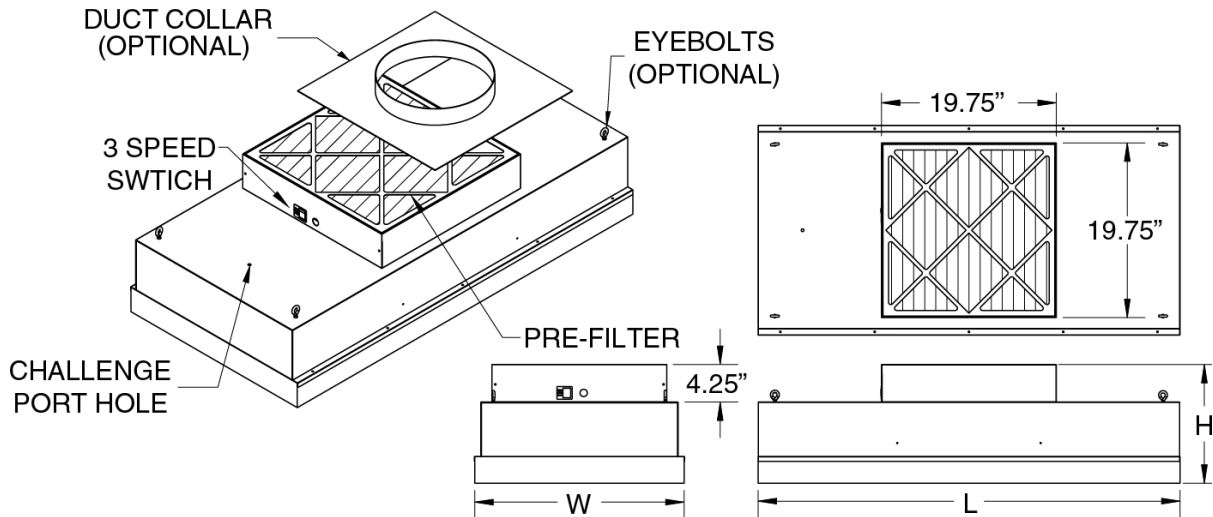

PRODUCT DIMENSIONS					
Nominal Unit Size (ft.)	Active Filter Area (sq. ft.)	W (in)	L (in)	H (in)	Weight (lbs.)
2' x 4'	7.2'	23.63"	47.56"	12.60"	71
2' x 4' (RSR)	5.2'	23.63"	47.63"	14.66"	71
2' x 3'	5.3'	23.63"	35.56"	12.60"	53
2' x 3' (RSR)	3.7'	23.63"	35.63"	14.66"	53
2' x 2'	3.4'	23.63"	23.56"	12.60"	44
2' x 2' (RSR)	2.2'	23.63"	23.63"	14.66"	44



**WHISPERFLOW® FFU ELECTRICAL DATA**

Nominal Unit Size	Filter	Motor HP	Voltage	Full Load Amps	Frequency (Hz)	HIGH	MED	LOW
2'x4'	HEPA	1/4	120	3.8	60	420	380	360
2'x4'	HEPA	1/4	208-230/240	1.6/1.8	60/50	380	310	240
2'x4'	HEPA (RSR)	1/4	120	3.8	60	420	380	360
2'x4'	HEPA (RSR)	1/4	208-230/240	1.6/1.8	60/50	380	310	240
2'x4'	ULPA	1/4	120	3.8	60	440	425	415
2'x4'	ULPA (RSR)	1/4	120	3.8	60	440	425	415
2'x3'	HEPA	1/4	120	3.8	60	330	300	285
2'x3'	HEPA	1/4	208-230/240	1.6/1.8	50/60	300	270	230
2'x3'	HEPA (RSR)	1/4	120	3.8	60	310	290	250
2'x3'	HEPA (RSR)	1/4	208-230/240	1.6/1.8	50/60	300	270	230
2'x2'	HEPA	1/4	120	3.8	60	300	250	230
2'x2'	HEPA	1/4	208-230/240	1.6/1.8	50/60	230	190	180
2'x2'	HEPA (RSR)	1/4	120	3.8	60	320	235	200
2'x2'	HEPA (RSR)	1/4	208-230/240	1.6/1.8	50/60	230	190	180

**WHISPERFLOW® FFU PERFORMANCE DATA**

Nominal Unit Size (ft.)	Filter	Sound (dB) @90FPM	HIGH	MED	LOW
2' x 4'	HEPA	49	800	720	590
2' x 4'	HEPA (RSR)	49	800	720	590
2' x 4'	ULPA	49	660	640	580
2' x 4'	ULPA (RSR)	49	660	640	580
2' x 3'	HEPA	49	675	630	560
2' x 3'	HEPA (RSR)	49	600	560	540
2' x 2'	HEPA	49	450	440	420
2' x 2'	HEPA (RSR)	49	360	330	300

**Notes:**

- Performance tested in accordance with the (ANSI/AMCA 210-07), (ANSI/ASHRAE 51-07) test standards for Certified Aerodynamic Performance Rating.
- Sound levels were measured with unit installed in a gasketed ceiling, in a standard room. Sound levels in dB were measured at a distance of 12 inches from the filter face, with the unit set to produce 90 fpm average face velocity. (Note that data is for a clean filter only. If fan speed is increased to compensate for filter loading the noise level will increase.)
- The unit set to produce 90 fpm average face velocity.
- All data is based on a unit with a 1" pre-filter and clean filter. Results will vary depending on filter media and ducting used.
- 90 fpm values are based on active filter face area.
- Heat Gain: BTU = Watts x 3.413
- Units tested 2019



### 3.3 WhisperFlow® Reverse Airflow FFUs

The exhaust flow fan filter unit converts any room into a negative pressure isolation/containment room with a HEPA filter that is 99.97% efficient at 0.3µm particle diameter. The unit mounts into the ceiling bay with ¼-20 UNC threaded inserts available on the corners for guy-wire suspension. The MERV 7 filter is 30% ASHRAE rated with an FDA-approved acrylic urethane sealant that prevents air leakage from the inside housing. There is a removable yellow power cord with a 4-pin connector that provides easy installation to Terra cleanrooms. This connector may be used with an optional wall plug adapter or may be removed entirely to hard-wire the FFU. The optional duct collar attachment allows connection to ducting system for safe exhaust outside of room.

The unit consists of a ¼ HP, thermally protected, variable speed motor that provides precise, fully adjustable airflow and drives a backward-curved centrifugal blower. The dust collection pan collects particles that fall off the outside of the filter to prevent them from being reintroduced into the surrounding environment. Air is drawn into the unit through the dust collection pan and exhausted out through the blue MERV 7 filter. The MERV 7 filter protects against dust and debris from falling into the impellor. The motor is controlled by an electrical speed dial control and this dial can function as ON/OFF for the blower starting from high to low flow rates. The dust collector pan can integrate with bag-in/bag-out (BIBO) systems and is easily removed for cleaning or maintenance.

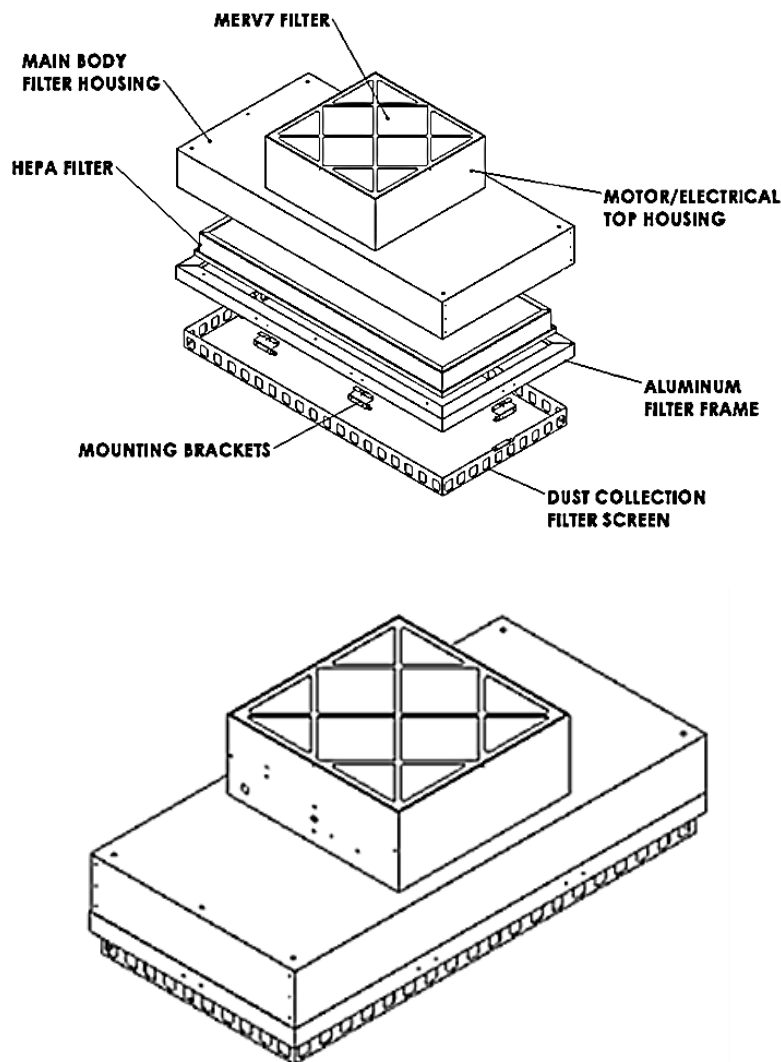

Figure 3: WhisperFlow® Reverse-Flow FFU



# WhisperFlow® Fan Filter Units

REVERSE AIR-FLOW WHISPERFLOW® PERFORMANCE DATA			
Nominal Unit Size (ft.)	Filter	Sound (dB) @90FPM	AIR FLOW (CFM) @ Max. Speed
2' x 2'	HEPA (RSR)	60	387 CFM
2' x 4'	HEPA (RSR)	60	353 CFM

REVERSE AIR-FLOW WHISPERFLOW® ELECTRICAL DATA						
Nominal Unit Size (ft.)	Filter	Motor HP	Voltage	Full Load Amps	Frequency (Hz)	Power Consumption (Watts)
2' x 2'	HEPA	1/4	115V	1.35	60	160
2' x 2'	HEPA	1/4	230V	0.66	50/60	125/170
2' x 4'	HEPA	1/4	115V	1.35	60	160
2' x 4'	HEPA	1/4	230V	0.66	50/60	125/170

PRODUCT DIMENSIONS					
Nominal Unit Size (ft.)	Active Filter Area (sq.ft)	W (in)	L (in)	H (in)	Weight (lbs.)
2' x 2' (RSR)	2.2'	23.625"	23.625"	17.975"	40
2' x 4' (RSR)	5.2'	47.625"	23.625"	17.975"	60



### 3.4 WhisperFlow® Smart® FFU with EC Motor

The Smart® WhisperFlow® has an electronically commutated (EC) brushless motor that allows for quiet, energy-efficient operation and infinitely variable speed control. This unit includes an internal microprocessor that can be incorporated into Building Management Systems (BMS) to allow remote monitoring and control. FFU includes MODBUS® networking control card with closed-loop control capability that supports air pressure, air flow, and particle count sensors. The motor control panel includes diagnostic indicator lights, manual speed adjustment, test probe jacks, CAT5e ports, control mode switch and MODBUS® address DIP switch bank. These units comply with Title 24 and ErP 2015 Directive.

The EC motor Control Card can be equipped with a 3/8" -diameter challenge port, which can be used to take differential pressure measurements to monitor filter performance or insert aerosols for leak-test certification. Port is capped when not in use.

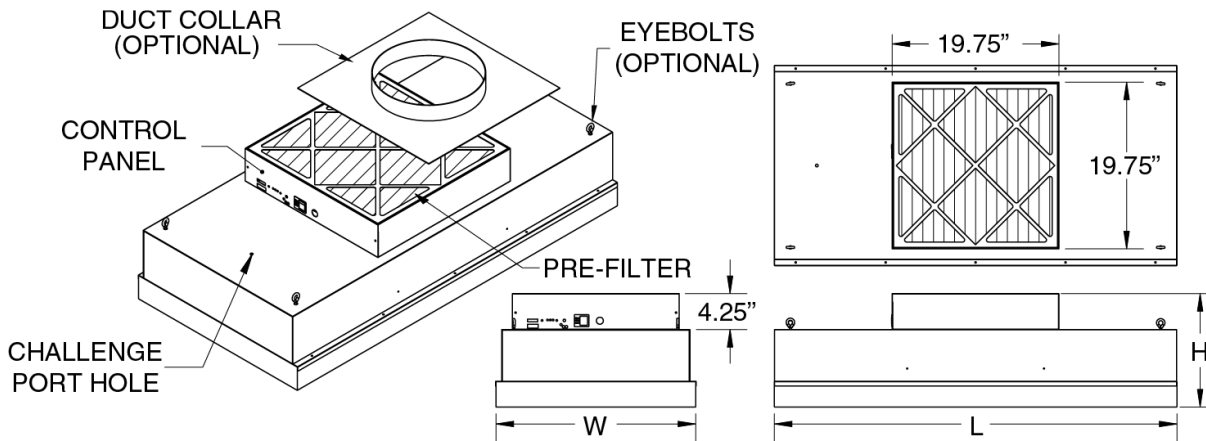

PRODUCT DIMENSIONS					
Nominal Unit Size (ft.)	Active Filter Area (sq. ft.)	W (in)	L (in)	H (in)	Weight (lbs.)
2' x 4'	7.2'	23.63"	47.56"	12.60"	71
2' x 4' (RSR)	5.2'	23.63"	47.63"	14.66"	71
2' x 3'	5.3'	23.63"	35.56"	12.60"	53
2' x 3' (RSR)	3.7'	23.63"	35.63"	14.66"	53
2' x 2'	3.4'	23.63"	23.56"	12.60"	44
2' x 2' (RSR)	2.2'	23.63"	23.63"	14.66"	44

PERFORMANCE DATA					
Nominal Unit Size (ft.)	Filter	Max CFM	Watts @ Max CFM	Watts @ 90 FPM	Sound (dB.) @ 90 FPM
2' x 4'	HEPA	900	350	180	40
2' x 4'	HEPA (RSR)	900	350	170	40
2' x 3'	HEPA	780	325	110	40
2' x 3'	HEPA (RSR)	780	325	80	40
2' x 2'	HEPA	475	225	100	40
2' x 2'	HEPA (RSR)	400	130	70	40



### 3.4.1 120V Configuration (default)

1. **Black** and **Red** wires are connected to the lower terminal.
2. Yellow Jumper Cable is installed.

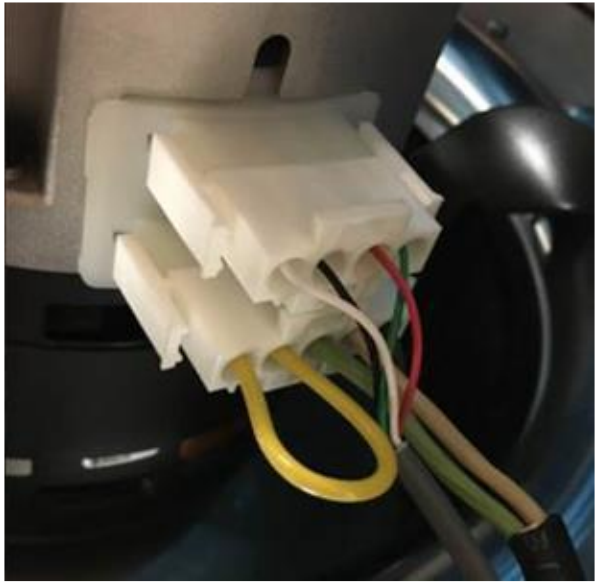
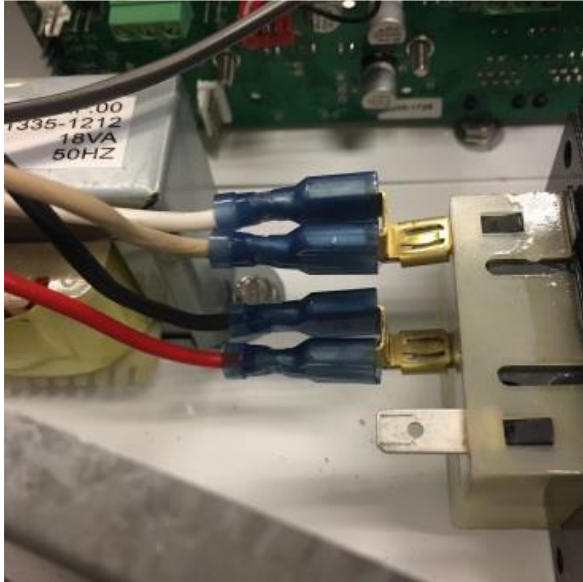

Figure 4: Backside view of 120V Configuration

### 3.4.2 220V Configuration

1. **Black** and **Red** wires connect to the upper terminal as shown.
2. Yellow Jumper Cable is removed.



Figure 5: Backside view of 220V Configuration

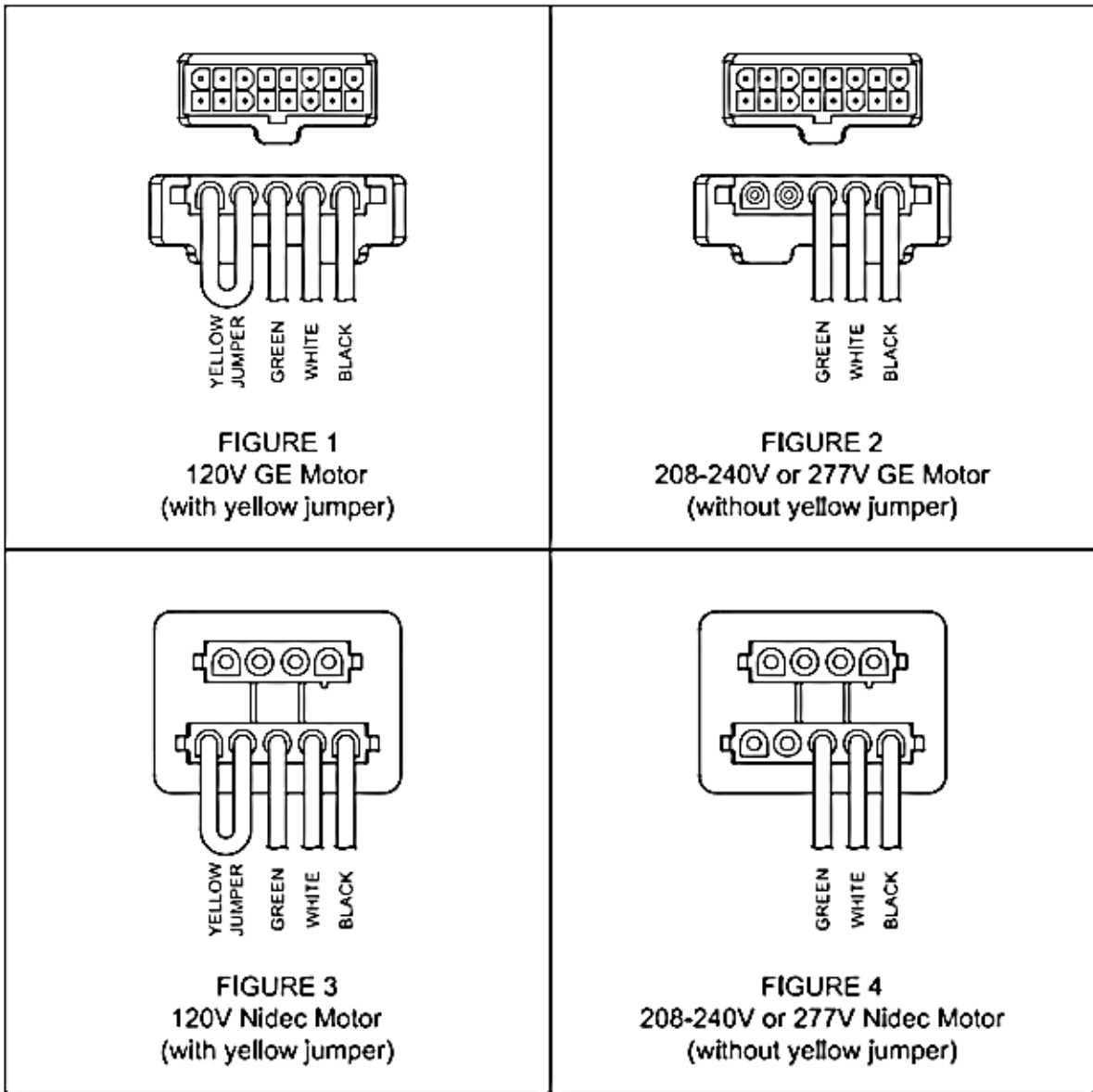

Figure 6: Motor Cable Configurations



### 3.4.3 EC Motor Control Card

The EC motor control card is a variable-speed controller designed for brushless DC (BLDC), electronically -commutated (EC) motors. The control card features industry standard MODBUS® networking, precision speed control (1-100%), and closed-loop control compatibility. The EC Motor Control panel provides access to LED diagnostics, manual speed adjustment, test probe jacks, CAT5e ports, the Control Mode DIP Switch, and the MODBUS® Address DIP Switch Bank.



Figure 7: EC fan filter unit control panel

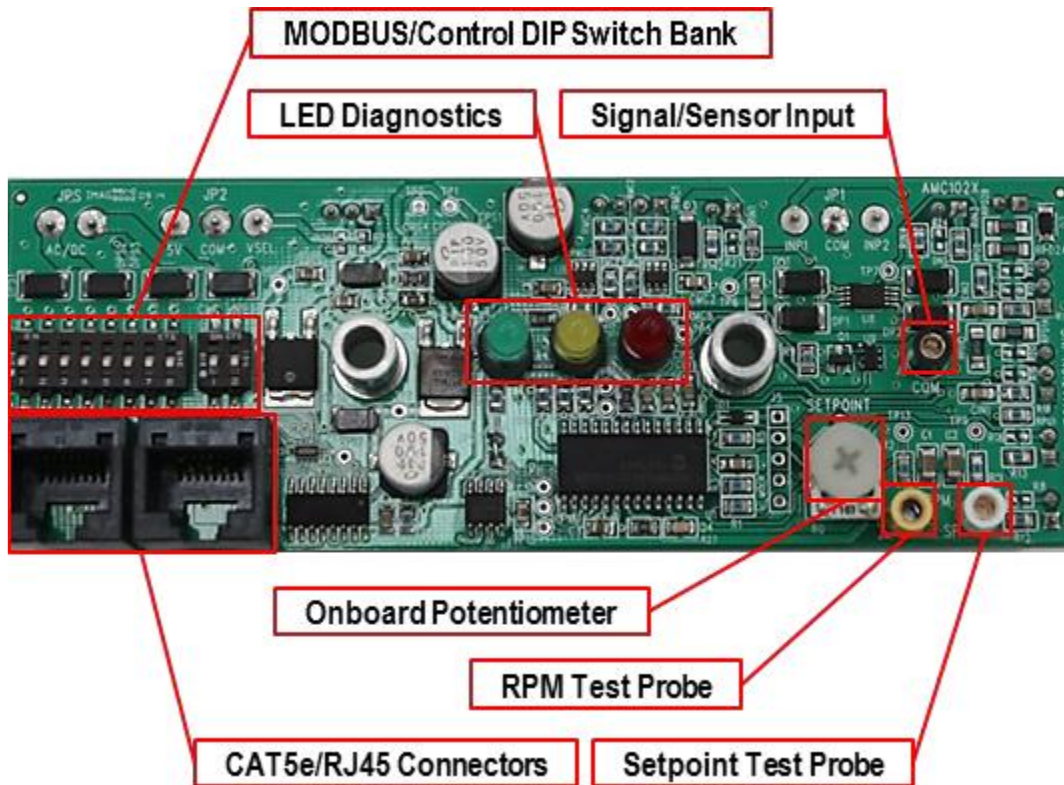



## EC Motor Control Card Specifications:

- Operating Temperature: 0 – 40°C
- Open-frame PCB with standoffs; Panel-mounted
- 12-24V DC Power Supply (or network power)
- Two non-directional CAT5e/RJ45 connections for networking
- Motor Tachometer RPM Control

## Analog Control Options:

- 5-10V from controlled voltage source
- 4-20mA signal from a sensor or potentiometer
- Internal Closed-Loop Control
- Manual Speed Adjustment

## PWM Speed Command Input:

- 10V, 80Hz

## TACH Motor Speed Input:

- 10V @ 1mA needed switched to ground
- Maximum 5000 RPM measured
- Minimum 60 RPM measured

## Industry Standard MODBUS® Networking:

- RTU Protocol
- RS485 9600,8,n,1

## Control Modes

The EC Motor Control Card offers three different control modes: MODBUS® RTU networking, 0-10 VDC analog control, or manual control through an onboard potentiometer.

### *Manual Control Mode:*

The onboard potentiometer can be manually adjusted at the EC Motor Control Panel using a Philips-head screwdriver. Clockwise rotation increases the motor output, and counterclockwise rotation decreases the motor output.

### *Analog Control Mode:*

Two terminals located on the EC Motor Control Card are designed to receive a 0-10 VDC demand signal or 4-20mA sensor to signal to regulate the motor output.

### *Network Control Mode:*

Each EC Motor Control Card in MODBUS® network must be assigned a unique address set in **binary format** using the eight DIP switches in the Address DIP Switch Bank.



## Test Probe Terminals

The test probe terminals are provided on the EC Motor Control Card to measure the motor RPM or check for a PWM signal using a multimeter.

Manual or Analog Control Modes:

To measure RPM, set the address DIP Switches at a value greater than 1. The test probe jacks will output 0-2000 mVDC to represent motor RPM.

Example: 500 mVDC = RPM

To measure demand signal, change the Address DIP Switches to the value of 0.

**Note:** Changing the address will not interrupt power to the Control Card.

Network Control Mode:

In the MODBUS® network control mode, the test probe terminals will always output 0-2000 mVDC to represent motor RPM.

Mod/BUS Control Mode DIP Switch Configurations		
		<b>Manual Control Mode</b> DIP Switch Bank S1: SWITCH #1 OFF SWITCH #2 OFF
		<b>Analog Control Mode</b> DIP Switch Bank S1: SWITCH #1 ON SWITCH #2 OFF
		<b>Network Control Mode</b> DIP Switch Bank S1: SWITCH #1 OFF SWITCH #2 ON
		<b>Closed-Loop Feedback</b> Network Control Mode DIP Switch Bank S1: SWITCH #1 ON SWITCH #2 ON
Example Addresses in Network Mode		
		<b>MODBUS® Address Value = 1</b> DIP Switch Bank S2: SWITCH #1 ON
		<b>MODBUS® Address Value = 21</b> DIP Switch Bank S2: SWITCHES #1,3,5 ON

**Note:** Address zero should not be used for Networked Control mode as it is reserved global commands.

**Note:** The EC Motor Control Card must be power-cycled for any address changes to take effect.



**Control Card Electrical Specifications**

Electrical Ratings	
Input Voltage, AC, 50/60Hz	2 – 28V <sup>1</sup> AC
Input Voltage, DC	14 – 30V DC
Operating Current, AC	35 mA AC
Operating Current, DC	30 mA DC
Accessory Current 5V, 10V	50 <sup>3</sup> mA DC
Accessory Current V.RFU2	100 <sup>3</sup> mA DC
<sup>1</sup> Refers to <b>actual AC voltage values</b>	
<sup>2</sup> V. RFU is rectified and capacitive-filtered, but is unregulated	
<sup>3</sup> Maximum current values stated in support of a single connected load	

“Stand Alone Operation” Power Source Ratings	
Supply Transformer Voltage Rating	12-24V AC
Supply Transformer Power Rating	2 VA
Regulated DC Supply Voltage Rating	14 – 30V DC
Regulated DC Supply Power Rating	2 W

Extended Accessory Output Currents for Stated Input Voltage Condition				
Input Voltage	Accessory Current, DC mA <sup>2</sup>			Suggested AC/DC Source Power Rating
	5V	10V	V.RFU	VA
14V DC Regulated	300	300	500	20,20,30
30V DC Regulated	50	50	500	10,10,60
12V AC <sup>1</sup> Transformer	100	100	100	5,5,5
28V AC <sup>1</sup> Transformer	50	50	200	10,10,25
<sup>1</sup> AC voltage spec refers to <b>actual AC voltage values</b> , i.e., not transformer ratings, etc.				
<sup>2</sup> Current values stated in support of a single connected load.				

Specifications	
Horsepower	1/3 HP
Voltage	120/240V, 50/60Hz
Speeds	300 – 1250 RPM
Inputs	2 Way Serial Communication & PWM
Frame	NEMA® 48
Enclosure	Continuous Air Over
Mounting	Belly Band
Amperage	4.2/2.7 Amps



## 4. Filter Cleaning and Replacement

The HEPA filter installed inside the FFU cannot be cleaned and will typically last for at least a few years depending on several factors such as ambient conditions, total operating time, fan speed setting (airflow rate), and maintenance of the pre-filters. When the unit is used in an ISO-classified environment, the HEPA filter will often perform sufficiently for a much longer period of time.

However, if air speed is significantly reduced or the HEPA filter fails to pass certification by an independent certifier, the HEPA filter may need to be replaced. Be sure to verify the proper operation of all other components in the system before attempting to replace the HEPA filter. A filter replacement alarm system is available to issue a warning alarm when pressure reaches twice the initial backpressure; system includes an audible buzzer with silencer that sounds when set point level is exceeded.

### 4.1 When Should I Change My Filter?

Filter replacement is not time dependent, but performance dependent. The filter should be changed when the fan filter unit can no longer achieve any of the required conditions such as: particle count, face velocity, room air change rate, and/or room pressure differential.

[Filter Replacement Alarms](#) provide automatic replacement alerts to avoid costly and unexpected operational interruptions. Simply adjust the pressure set-point to adjust the frequency of filter alerts for replacement. Terra Universal provides a wide selection of cleanroom-appropriate instruments including gauges, particulate monitoring systems, and fan filter packages with automatic replacement alarms.



## 4.2 Top-Side Filter Replacement

Topside replaceable FFUs require the units to be removed from the cleanroom ceiling or hood for filter replacement. This replacement may require shutting down the cleanroom operation.

1. Disconnect the fan/filter unit from the PDM.
2. Attach double stick tape to a polypropylene panel – place on all four sides. The panel protects the HEPA filter from damage (See Figure 11).
3. Place the polypropylene panel over the filter screen, making sure that it only adheres to the screen without overlapping the edges (See Figure 12).
4. Push one side of the FFU up, rotate it 90° and lower through the ceiling grid.
5. Place the unit on a flat work surface and remove the 10 sheet metal screws that hold the HEPA/ULPA filter to the case (See Figure 17).
6. Replace with a new HEPA/ULPA filter carefully handling edges only.
7. Secure filter to the case with the same screws used previously.
8. Place unit back onto the ceiling grid.

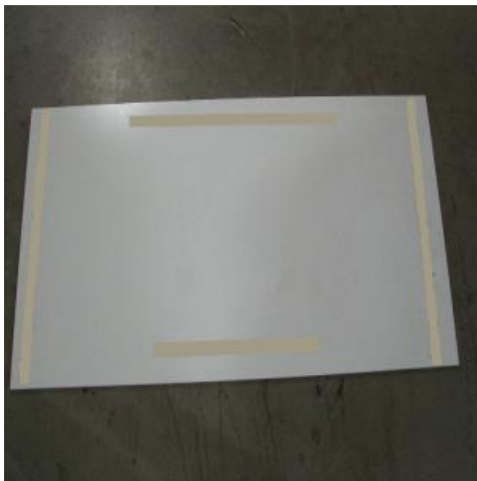

Figure 8: Polypropylene panel with tape



Figure 9: Panel attaching to exposed HEPA filter



Figure 10: Panel fully attached to filter screen without overlapping edges



Figure 11: FFU pushed up on one side for removal



Figure 12: Personnel rotating FFU to remove from ceiling grid



Figure 13: FFU rotated 90° and lowered completely from ceiling grid

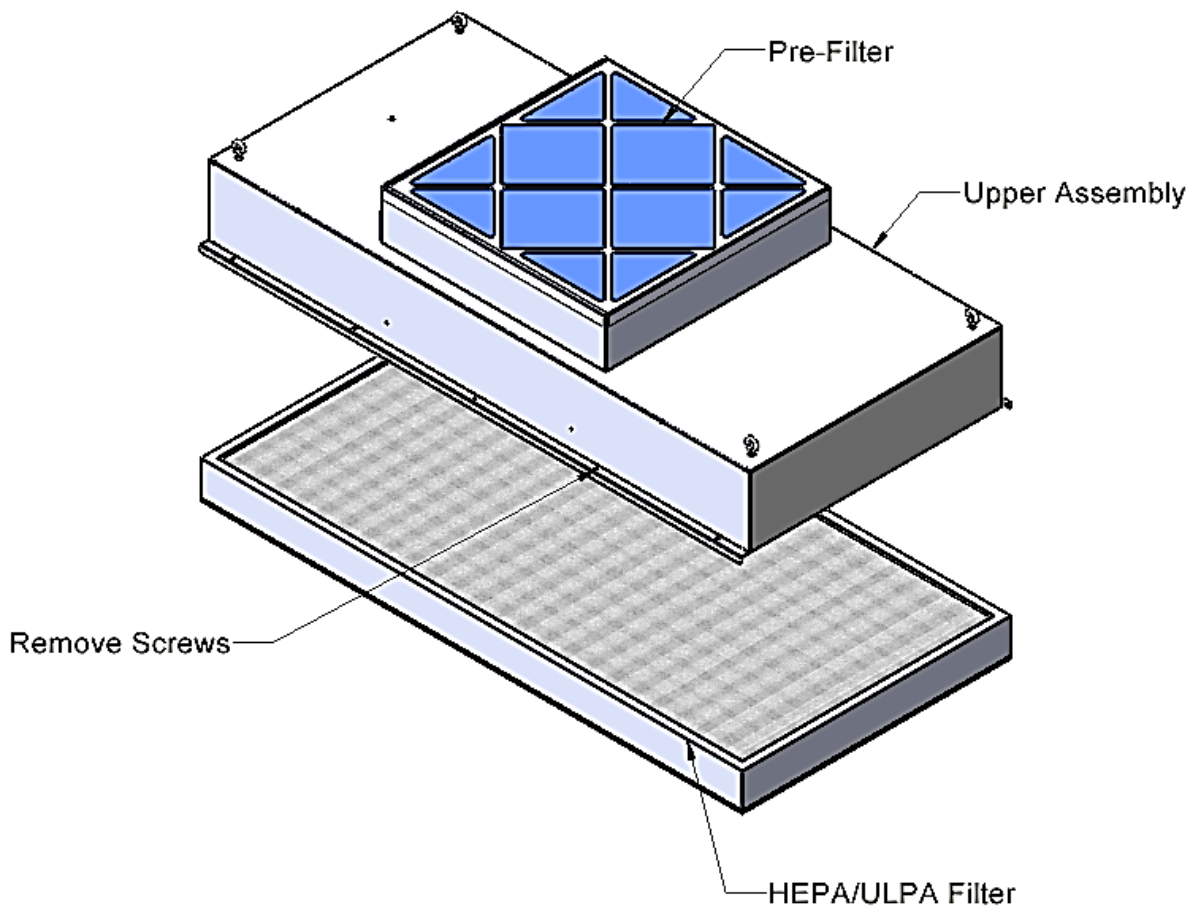

Figure 14: Diagram of FFU assembly



## 4.3 Room-Side Gel Seal Filter Replacement (BIBO compatible)



WARNING

**WARNING:**

**For applications involving risk of exposure to harmful particulates or pathogens in the filter media, use appropriate PPE and reference your facility's protocol for safe removal and disposal of filters.**

The Room-Side Replaceable (RSR) FFU is designed so that the HEPA or ULPA filter can be replaced from inside the cleanroom without breaching the controlled environment. The filter assembly is separate from the fan module, which stays in place in the ceiling grid.

RSR FFU filters use gel seals. Gel-seal filters ensure that air flows directly through the fan filter media rather than around it. Terra gel seal FFUs feature retardant, phosphorous-free polyurethane gel-sealant to seat against a knife-edge on the fan housing. The seats for RSR filters combine two different edge materials. The first is a track channel that contains the gel seal. The other side of the seal is a “knife-edge” that penetrates the gel and seals the enclosure.

DO NOT TOUCH the gel and do not allow the gel to collect dirt, dust, grease, or oil. Be vigilant of debris or glue fragments in the corners of the unit, as these areas are the most susceptible to collecting and retaining residues, contaminants, and material fragments.

DO NOT TOUCH the upstream side of the HEPA or ULPA filter.

### Step 1: Remove the Existing HEPA or ULPA Filter

1. First, you must remove the stainless steel screen covering the filter held in place with friction catches (See Figure 8). This screen protects the filter from damage and enhances airflow uniformity.
2. Next, rotate the metal tabs that help hold the HEPA filter in place (See Figure 9).
3. Gently let the used filter drop down, and set aside for disposal.
4. If the gel seal does not release, gently pull down on the HEPA or ULPA filter to release the seal, then lower the filter straight down through the housing.
5. After removing the filter, ensure the fan filter unit knife edges are free and clear of any debris. Wipe any residual gel from the knife-edge to prepare for the replacement filter.

### Step 2: Install the new HEPA or ULPA Filter

The following steps will require assistance from another person to help center and secure the new filter.

1. Inspect the gel seal of the filter being inserted, to ensure adequate gel material is present and within 1/16" from the top of the gel track.
2. Before inserting the filter, ensure the frame is flat, level, and centered to the housing with equal clearance on all four sides.
3. Position your new filter carefully before pushing into place; the knife-edge of the fan module should be centered in the channel (equal amounts of gel on both sides). Figure 10 shows the gel-filled channel of the RSR filter.
4. Lift the filter by the frame with one person on each end. Carefully lift the fan filter in unison.
5. DO NOT LET GO OF THE FILTER UNTIL SECURED.
6. Hold the filter in place while the second person tightens the filter clamps.
7. To secure the filter clamps, rotate the (4) filter clamps back to the original position, then tighten with an appropriately sized wrench.
8. Reinstall the stainless steel screen by pushing up on the friction catches until it clicks into place.
9. To replace the pre-filter located at the top of the fan module, slide the old filter out of the two tracks holding it in place on top of the FFU and then slide in the new pre-filter.
10. HAND TIGHTEN ONLY. DO NOT OVERTIGHTEN.



Figure 15: Friction catches hold the screen to the fan module housing



Figure 16: Filter-face grille's metal tabs

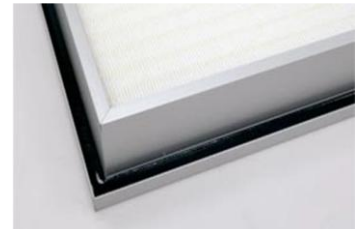
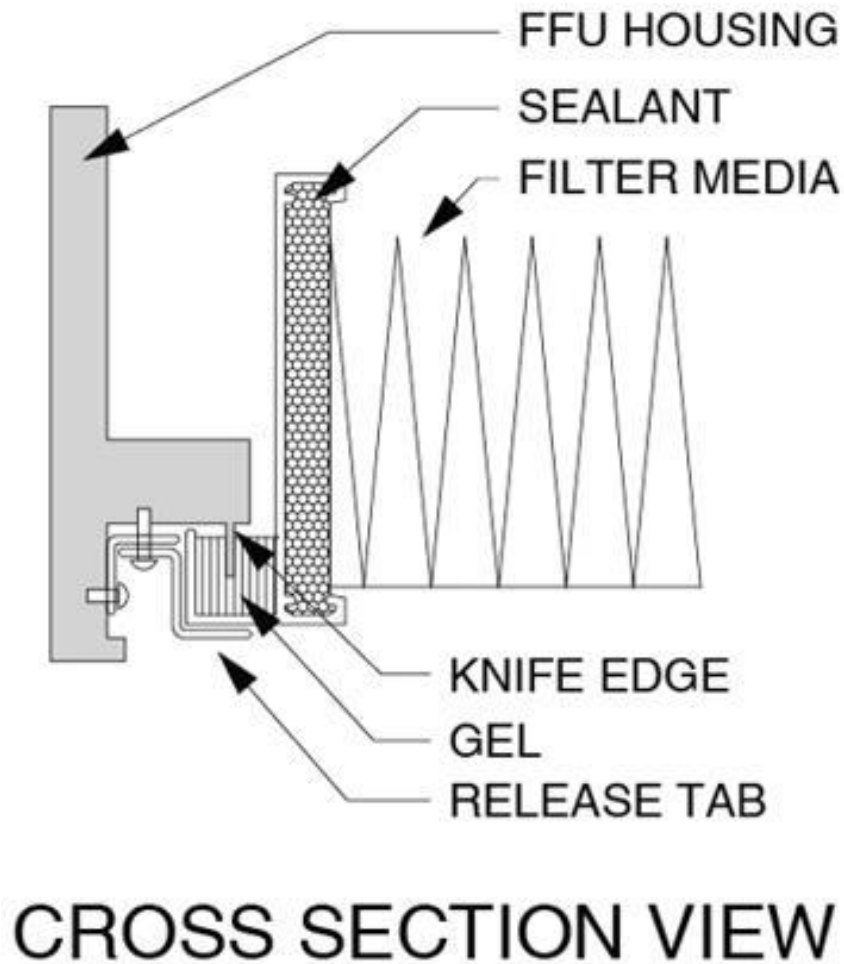

Figure 17: Gel-filled channel of RSR filter





### 4.3.1 Gel Seal Filter Damage Inspection

It is important to inspect the gel seal and handle it with care to avoid damage during installation. Damage can occur for numerous reasons including age, chemical exposure, excessive penetration, shearing, or tearing caused by removing the knife-edge too quickly from the gel channel. All Terra filters should be visually inspected for freight damage before installation.

#### **Gel Seal Chemical Damage**

Chemical damage is categorized into two groups; mild and severe. Chemical damage can occur to the gel seal when exposed to internal or external substances, or as the result of environmental conditions:

- Reversion (degradation or liquefaction) of the gel into a liquid state.
- Chemical attack, typically caused by oxidizing cleaning agents, may incur a loss of surface tack, blisters, or skin formulation on the surface of the gel.
- Ultraviolet (UV) light degradation may cause the gel surface to craze, crack, or liquify.
- Thermal degradation results in a loss of elasticity and surface tack that results in a gel that becomes hard and less malleable.

#### **Mild Chemical Damage**

Mild chemical damage results in slight changes to the physical characteristics of the gel, but are not considered severe enough to damage the fit and function of the gel seal including:

- Change or loss of color that does not have any measurable effect on the elasticity or hardness of the gel.
- Formation of a slight exterior skin only noticeable when the gel is “pinched” between the fingers.
- Minor reduction in surface tackiness.

**Filters that exhibit only mild signs of chemical damage are likely to continue to seal and perform without issue.**

#### **Severe Chemical Damage**

Severe chemical damage occurs when chemical substances cause major and significant changes in gels’ physical characteristics.

- Significant changes in hardness or elasticity
- Complete loss of surface tack
- Formation of thick skin on gel surface layer
- Formation of wet areas on the gel, or liquefaction that results in gel drip.

**If gel seal filter leaks are detected upon installation, remove the filter and replace it with a new one before reinstalling and testing.**



## Gel Seal Physical Damage

Physical damage to the gel seals or HEPA/ULPA media are the most common archetypes for filter damage. Because damage can occur at any stage of the storage, handling, shipping, and installation phase, all filters and gel seals should be visually inspected for freight damage before installation.

Damage to the filter media or gel seal can range from very mild to unrecoverable. The most common form of physical damage is caused by removing the knife edge from the gel too quickly.

The most common causes of gel seal filter include:

- The knife-edge is removed too quickly from the gel, which causes shearing.
- Knife edge is inserted too deeply into the gel channel, which can cause the gel to split in half and compromise the seal. The maximum recommended penetration of the knife-edge should be no greater than 70% of the inside channel gel width.
- Abrasion caused by friction between the gel seal and the housing, tools, packaging material, or hands.
- Packaging materials such as films and plastics readily stick to gel materials; this may cause damage if hastily removed while in contact with the gel.
- Knife edge seal is too sharp, which can cause over-penetration of the gel.

## Mild Physical Damage

Mild physical damage is considered superficial and will not interfere with the proper sealing of the fan filter unit. Lines, ripples, and rough spots that penetrate the gel no further than 0.25 inches (6 mm) are not expected to compromise the fit and function of the gel seal.

**Filters that exhibit only mild signs of chemical damage are likely to continue to seal and perform without issue.**

## Severe Physical Damage

Severe damage occurs when tears, flaws, or cuts penetrate beyond the first 0.25 inches of the gel seal. The most common causes of severe damage include:

- Shearing occurs when the knife edge is removed too quickly from the gel.
- The knife edge is too sharp and cuts through the gel seal.

**Gel seals with severe physical damage will have a higher probability of failure.**



## Gel Seal Housing and Cross Section

The below figures illustrate examples of gel seals that incurred shearing or cut-throughs. In both scenarios, there is a high probability that the seal is compromised and will require replacement.

The ideal outcome for gel filters is for them to be carefully removed and reinstalled on one or more instances. When installed with care, gel seals will accommodate multiple re-installations. If necessary, a scan test can verify and confirm the integrity of the filter and seal system upon re-installation.

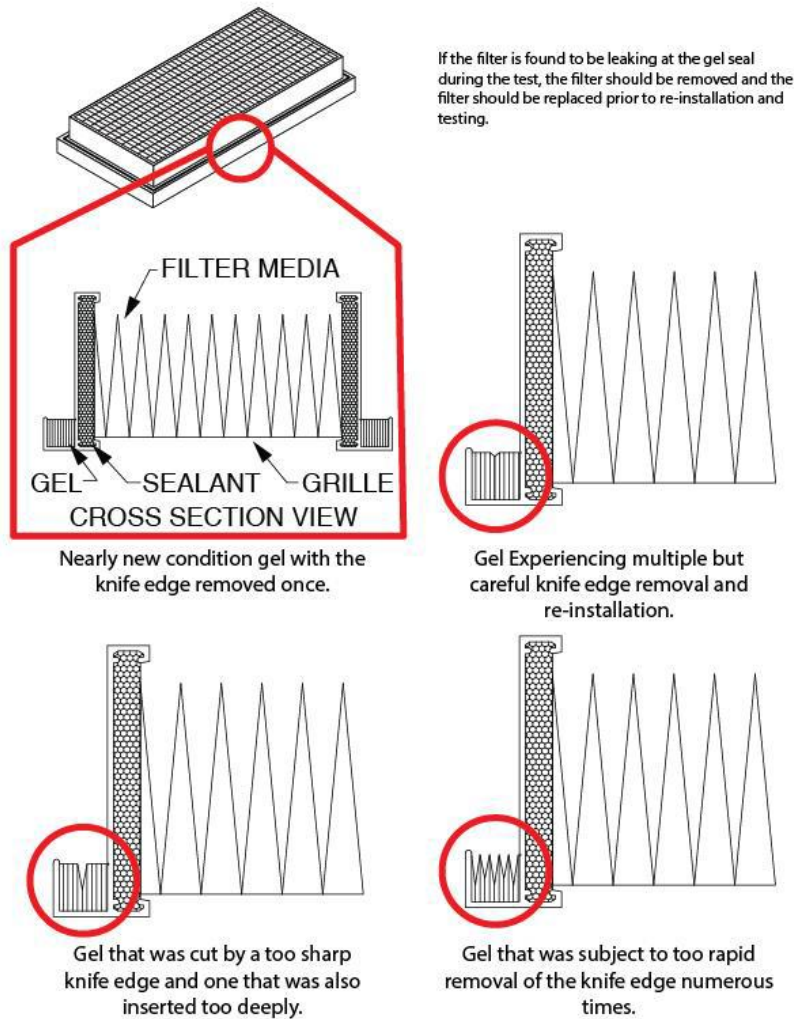



## 4.4 WhisperFlow® Portable FFU Filter Replacement (6601-66)

The WhisperFlow® Portable Filtration System (Cat. No. 6601-66) is a freestanding, mobile fan filter unit designed for portable cleanroom and critical environment applications. It features a stainless steel enclosure (ULPA models) or powder-coated steel enclosure (HEPA models) mounted on locking casters, a ULPA or HEPA filter, an EC motor (ULPA models) or AC motor (HEPA models) control panel accessible from the front face of the unit, a variable speed dial, a filter back pressure monitor gauge, adjustable air outlet vent, and a duct flange. The following instructions describe how to safely remove and replace the HEPA/ULPA filter.



Figure 18: WhisperFlow® Portable FFU (6601-66) — front view



**Before performing any filter replacement, disconnect all power to the unit and lock out/tag out the power source.**



**DO NOT touch the filter media surface with bare hands, tools, or other objects. Handle the filter only by its frame. Damage to the filter media voids the warranty.**

### Overview

The Portable FFU uses a rear-access panel design for the main HEPA/ULPA filter. The back panel of the unit is removable, providing direct access to the HEPA/ULPA filter installed inside the housing. The pre-filter is accessible from the front of the unit.



Figure 19: Portable FFU with rear access panel removed, showing filter access



## Step 1: Access the Filter — Remove the Rear Panel

1. Ensure the unit is powered OFF and all power has been disconnected. Lock out / tag out if required by your facility.
2. Position the unit so the rear face is accessible. Apply the wheel locks (casters) to prevent the unit from rolling.
3. Locate the rear panel. The panel is secured by friction catches, clips, or fasteners along its perimeter.
4. Release the catches or unfasten the panel hardware.
5. Carefully lift the rear access panel away from the unit and set it aside on a clean, flat surface.



Figure 20: Rear panel clip detail — release clips to remove panel

## Step 2: Remove the Existing Filter

1. Visually inspect the filter and its surrounding frame before handling.
2. Grasp the filter only by its rigid frame. Do NOT touch the filter face or media.
3. Carefully slide or lift the filter straight out of its mounting track.
4. If the filter does not release easily, check for any retaining clips or tabs and release them.
5. Carefully lower the used filter and place it in a sealed disposal bag. Follow your facility's filter disposal protocol.
6. Inspect the filter track and housing interior for debris. Wipe clean with a damp, lint-free cloth if necessary and allow to dry.

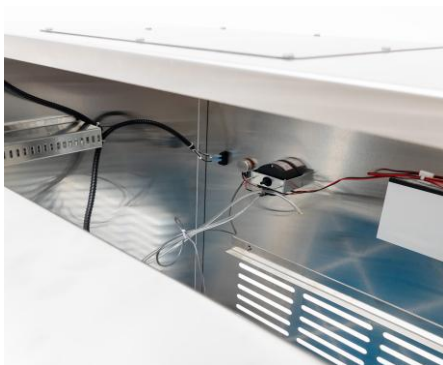

Figure 21: Internal housing with filter removed



Figure 22: Filter track — ready for new filter

## Step 3: Install the New HEPA/ULPA Filter

1. Verify the replacement filter is the correct part number, size, and filter grade for the unit.
2. Inspect the new filter's frame and gasket/seal for any damage before installation.
3. Orient the filter correctly — check for an airflow direction arrow on the filter frame.



4. Carefully align the filter with the mounting track inside the housing. Insert the filter frame into the track evenly on all four sides.
5. Gently push the filter flush against the housing gasket to form a complete seal.
6. If retaining clips or tabs are present, re-engage them to secure the filter.



Figure 23: FFU with ULPA filter — filter seating reference

#### Step 4: Reinstall the Rear Access Panel

1. Verify the new filter is fully seated and secured before replacing the rear panel.
2. Align the rear access panel with the panel opening on the unit housing.
3. Press the panel firmly into place until all catches, clips, or fasteners engage securely.
4. If fastener hardware was removed, reinstall and tighten appropriately. Do not overtighten.
5. Perform a visual inspection to confirm the panel is flush and the unit housing is fully closed.



Figure 24: Reconnecting cables after panel reinstall



Figure 25: Challenge port — verify connections before power-on

#### Step 5: Post-Replacement Startup and Verification

1. Remove all lock-out / tag-out devices and reconnect power to the unit.
2. Power on the unit and observe operation. The fan should start and produce airflow.
3. Verify there are no unusual noises, vibrations, or visible air leakage.
4. Allow the unit to run for a minimum of 5 minutes and verify airflow at the filter face.
5. Terra Universal recommends validation by a third-party testing service (HEPA filter integrity leak test).



## Pre-Filter Replacement

The portable FFU includes a MERV 7 or charcoal pre-filter, depending on the model, that should be inspected monthly and replaced when visibly loaded or when airflow performance decreases.

1. Power off the unit and disconnect power.
2. Locate the pre-filter slot on the front of the unit.
3. Slide the used pre-filter out of its retaining track.
4. Insert a new MERV 7 or charcoal pre-filter (per your model) oriented correctly per the airflow direction arrow.
5. Slide the new pre-filter fully into the track until it seats completely.
6. Restore power and verify operation.

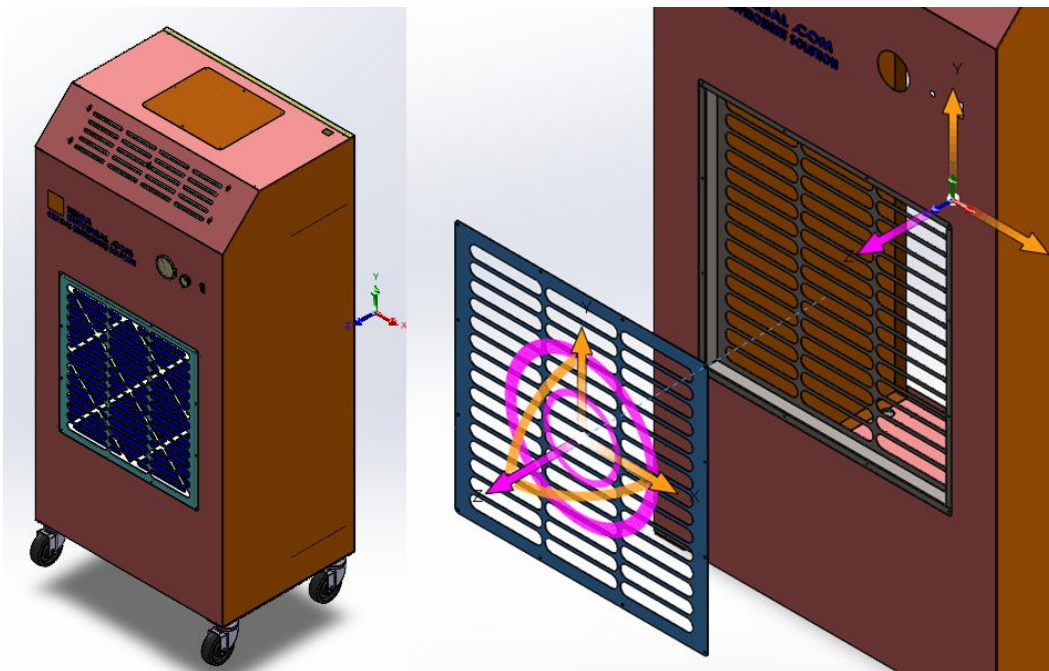
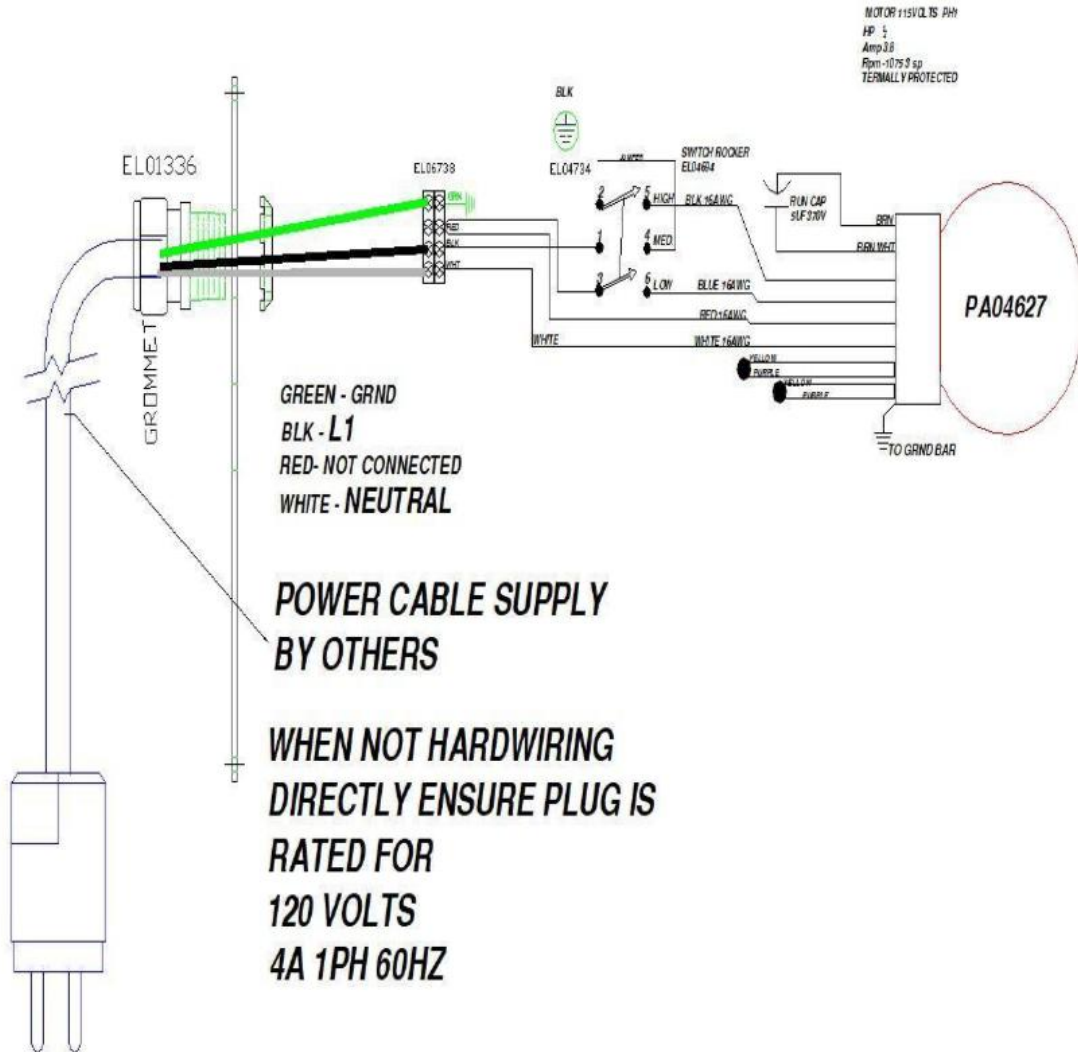

Figure 26: Pre-filter removal from front panel



## 5. Wiring Diagrams

- Smart@WhisperFlow®
- WhisperFlow®





# WhisperFlow® Fan Filter Units

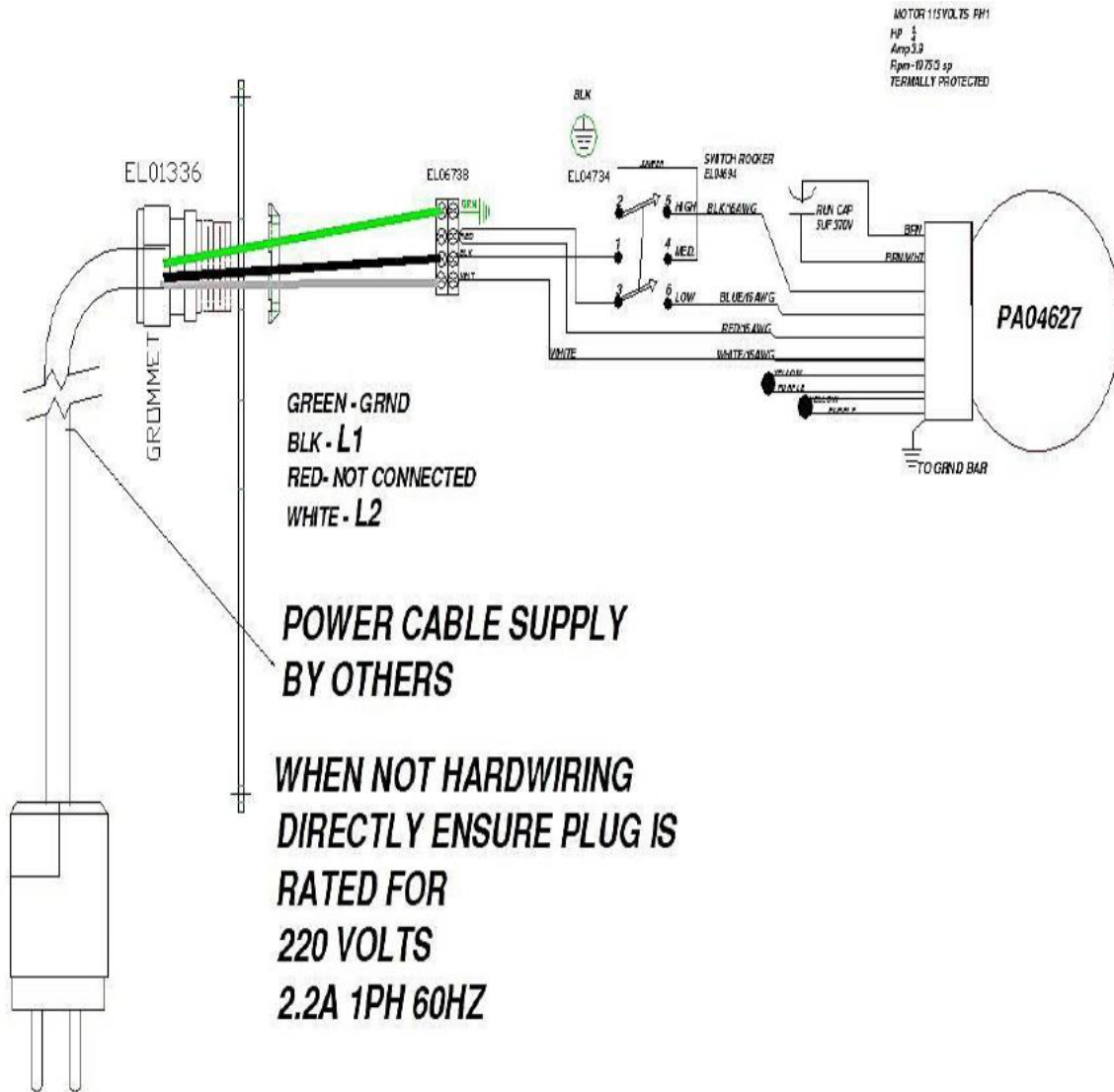



## 6. Speed Configuration with Power Distribution Module (PDM)

The electric circuit design of the PDM limits speed configurations of FFU's with PSC motors. All FFU's with PSC motors should be switched to MEDIUM or HIGH speed setting when connected to a PDM. Thermal overload can occur when one FFU is set to LOW, and the others are set to MEDIUM or HIGH speed settings. The FFU motor set to LOW can draw excess current from the PDM which can lead to thermal overload on the motor, motor failure, and/or electrical hazards.

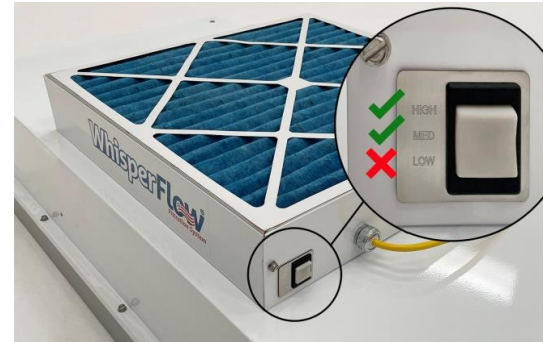

### NOTES:

- Setting all FFU's with PSC motors to LOW does not cause an immediate problem. However, it is not advised as there is a risk of accidentally adjusting one FFU's speed setting to HIGH or MEDIUM, which could lead to thermal overload on a FFU motor that is still on LOW speed.
- "Night service" mode from the control panel is unaffected and operates correctly when all individual FFU's are switched to HIGH or MEDIUM speed settings.
- This limitation does not apply if the FFU with PSC motor is used individually without a PDM, and powered directly from a standard wall outlet.
- This limitation does not apply to Smart® FFU's with Electronically Commutated (EC) motors. Smart® FFU's do not use PSC motors.

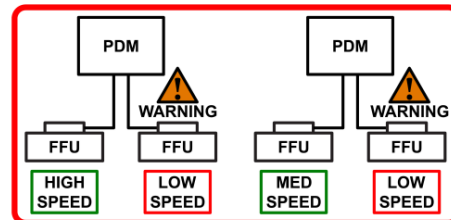
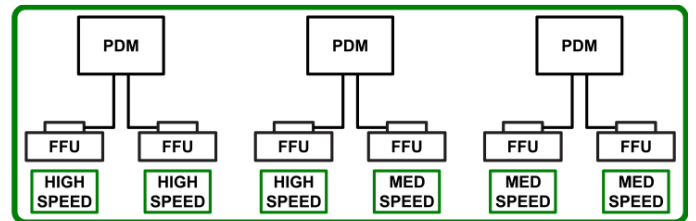

SEE NOTE #1

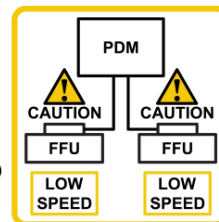



## 6.1 How to Connect Low Mode for Standalone Fan Filter Units

- FFUs default to night mode for use in our cleanrooms
- To enable low air flow setting on a standalone 3-speed FFU (non-EC motor), perform the following instruction:

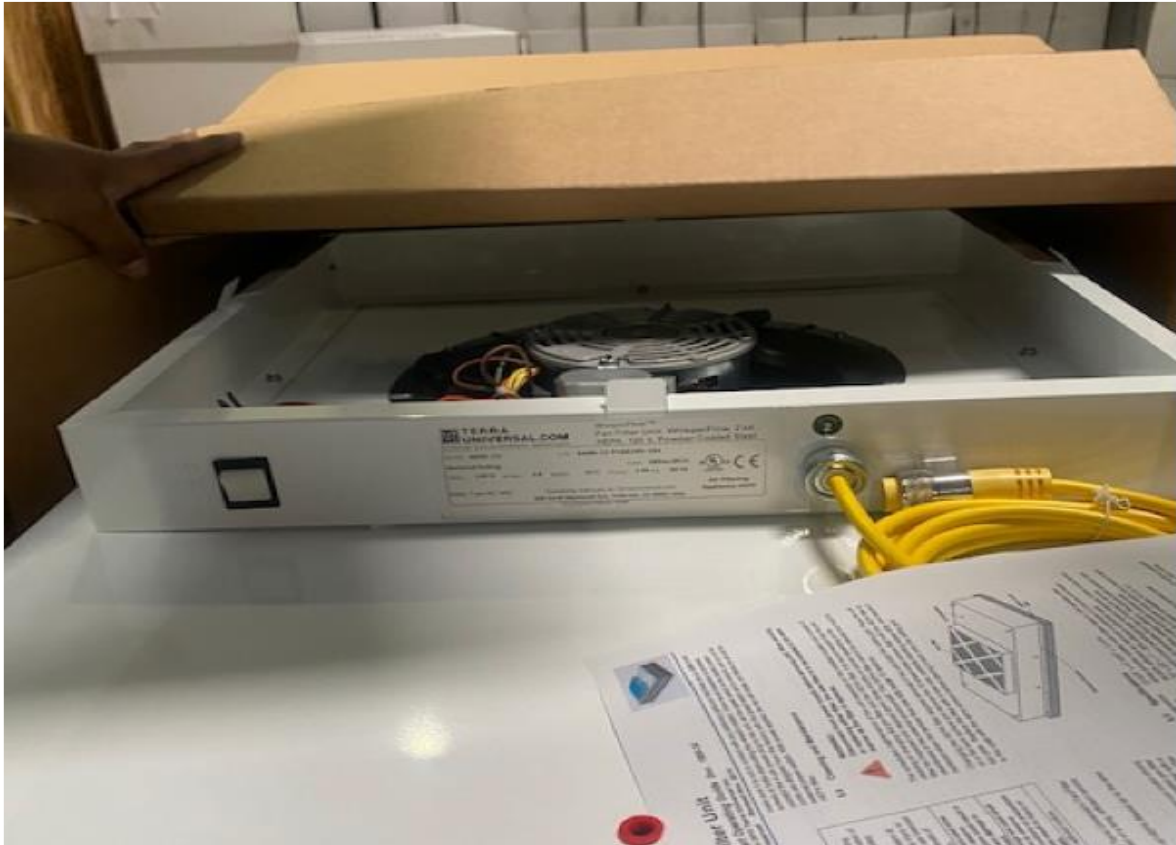

Figure 27: Overall picture of FFU



Figure 28: Red wire comes disconnected



Figure 29: Take red cable and insert into empty slot on connector



Figure 30: Low mode is activated



## 7. Testing

WhisperFlow® fan filter units are thoroughly tested at the factory before shipment. However, because of the “rigors” of shipping, Terra Universal encourages re-test after installation.

Terra Universal recommends that the customer contact an independent organization, with technicians trained and experienced in performance evaluation and maintenance of clean air equipment.

All filters are tested with properly calibrated equipment to IEST-RP-00034 and all filters are UL 900 recognized. If your filters have special requirements, please see original engineering specifications for your specific project.

## 8. Troubleshooting

### Low Air Velocity

1. Check the prefilter; clean or replace if dirty.
2. Adjust the fan speed to a higher output.
3. Verify the power output for voltage, amperage, and distribution frequency.
4. Replace HEPA/ULPA filter if air velocity does not change.

### High Air Velocity

1. Adjust the fan speed to a lower output.

### Non-Laminar Flow and/or Excessive Contamination

1. Verify that no obstructions are upstream of airflow pattern.
2. Ensure that no other air-moving devices are operating in or around cleanroom.
3. Confirm the air velocity is properly working, and, if low, follow the “Low Air Velocity” procedure.
4. Run a smoke and photometer test on HEPA filter. Seal or replace HEPA filter if needed.

Contact Technical Support at:

Terra Universal Inc.

714-578-6100

## 9. Replacement Parts

Replacement parts apply for the following models:

- Standard WhisperFlow®
- Smart® WhisperFlow® EC (Electronically Commutated) Motor
- Narrow WhisperFlow®
- WhisperFlow® Reverse-Flow
- Ducted Filter Module WhisperFlow®
- WhisperFlow® Portable FFU (6601-66, 6601-66A)

Please contact us for information on replacement parts. Provide sales associate with pertinent information, such as serial number, model number and date. Information located on the FFU label on the lower part of the assembly.

Order Number \_\_\_\_\_

Serial Number \_\_\_\_\_

Unit Model Number \_\_\_\_\_

Date \_\_\_\_\_

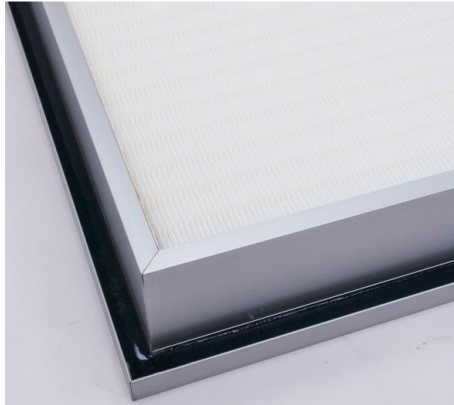

Room-side Replaceable Filters			
Nominal Unit Size (ft.)	Filter	Frame Material	Part Number
2' x 4' (RSR)	HEPA	Aluminum	6601-25-R
2' x 3' (RSR)	HEPA	Aluminum	6601-26-R
2' x 2' (RSR)	HEPA	Aluminum	6601-27-R
2' x 4' (RSR)	ULPA	Aluminum	6601-28-R
2' x 3' (RSR)	ULPA	Aluminum	6601-29-R
2' x 2' (RSR)	ULPA	Aluminum	6601-30-R

Top Side Replaceable Filters			
Nominal Unit Size (ft.)	Filter	Frame Material	Part Number
2' x 4' (Top Side Replaceable)	HEPA	Aluminum	6601-25
2' x 3' (Top Side Replaceable)	HEPA	Aluminum	6601-26
2' x 2' (Top Side Replaceable)	HEPA	Aluminum	6601-27
2' x 4' (Top Side Replaceable)	ULPA	Aluminum	6601-28
2' x 3' (Top Side Replaceable)	ULPA	Aluminum	6601-29
2' x 2' (Top Side Replaceable)	ULPA	Aluminum	6601-30

## 10. Accessories



Ionizing Bar		
Length	Voltage	Part Number
44"	240 V	2005-49-220
44"	120 V	2005-49
33"	240 V	2005-48-220
33"	120 V	2005-48
22"	240 V	2005-47-220
22"	120 V	2005-47



<b>Challenge Port Kit</b>	<b>6601-99</b>
---------------------------	----------------



Power Distribution Modules (PDM's)		
PDM Type	Voltage	Part Number
Primary	120 V	6600-29B-T
Secondary	240 V	6600-29B-S-220
Secondary	120 V	6600-29B-S
Primary	240 V	6600-29B-P-220
Primary	120 V	6600-29B-P
Booster	240 V	6600-29B-B-220
Booster	120 V	6600-29B-B
Wireless Control, Primary	240 V	6600-29A-WL-P-220
Wireless Control, Primary	120 V	6600-29A-WL-P
Power Outlet	240 V	6600-27-220
Power Outlet	120 V	6600-27

**Power Cord Adapter** 6601-13



**Filter Replacement Alarm** 2625-54B-SS

Note: PDMs require a control panel

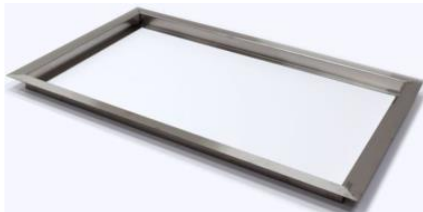

**Eyebolt Package** 6601-02

Mounting Frames		
Material	Size	Part Number
Stainless Steel	2'x4'	6604-02
Stainless Steel	2'x3'	6604-01
Stainless Steel	2'x2'	6604-00



## **11. Warranty**

For more information about our warranty system, please visit our company's warranty website.

For warranty service, technical support, or replacement parts, contact Terra Universal:

- Phone: (714) 578-6000
- Email: [sales@terrauniversal.com](mailto:sales@terrauniversal.com)
- Web: [TerraUniversal.com](http://TerraUniversal.com)
- Address: 800 S. Raymond Ave., Fullerton, CA 92831



***Thank you for ordering from  
Terra Universal!***