

Instruction book

Oil-injected screw compressors

G 2 VSD, G 3 VSD, G 4 VSD, G 5 VSD,
G 7 VSD

Atlas Copco

Oil-injected screw compressors

G 2 VSD, G 3 VSD, G 4 VSD, G 5 VSD, G 7 VSD

Instruction book

Original instructions

WARNING



Read all safety warnings, instructions, illustrations and specifications provided with this product. Failure to follow all instructions listed in this instruction book may result in personal injury, death and/or property damage.

COPYRIGHT NOTICE

Any unauthorized use or copying of the contents or any part thereof is prohibited.

This applies in particular to trademarks, model denominations, part numbers and drawings.

This instruction book is valid for CE, non-CE as well as UKCA labelled machines. It meets the requirements for instructions specified by the applicable European directives or UK statutory instruments as identified in the Declaration of Conformity.

This product is intended for marketing in the United States and Canada.

November 2023

No. 2920 7219 30

www.atlascopco.com

Atlas Copco

Table of contents

1	Safety precautions.....	6
1.1	SAFETY ICONS.....	6
1.2	GENERAL SAFETY PRECAUTIONS.....	6
1.3	SAFETY PRECAUTIONS DURING INSTALLATION.....	7
1.4	SAFETY PRECAUTIONS DURING OPERATION.....	9
1.5	SAFETY PRECAUTIONS DURING MAINTENANCE OR REPAIR.....	10
1.6	DISMANTLING AND DISPOSAL.....	11
2	General description.....	13
2.1	INTRODUCTION.....	13
2.2	AIR FLOW.....	17
2.3	OIL SYSTEM.....	20
2.4	COOLING SYSTEM.....	22
2.5	REGULATING SYSTEM.....	23
2.6	CONTROL PANEL	24
2.7	ELECTRICAL SYSTEM.....	25
2.8	PROTECTION OF THE COMPRESSOR.....	26
2.9	AIR DRYER.....	27
3	Controller.....	28
3.1	CONTROLLER FUNCTIONS.....	28
3.2	CONTROL PANEL.....	31
3.3	ICONS USED.....	32
3.4	MAIN SCREEN.....	34

3.5	WARNING.....	34
3.6	SHUTDOWN.....	35
3.7	SERVICE WARNING.....	40
3.8	REMOTE CONTROL.....	41
3.9	SCROLLING THROUGH SCREENS.....	41
3.10	CALLING UP MAIN SCREEN.....	42
3.11	CALLING UP/MODIFYING PRESSURE BAND SETTINGS.....	43
3.12	CALLING UP RUNNING HOURS.....	46
3.13	CALLING UP SOFTWARE RELEASE.....	47
3.14	CALLING UP BLUETOOTH PAIRING/ DISCOVERY MODE.....	47
3.15	ADVANCED MENU.....	48
3.16	SERVICE MODE.....	48
3.17	SCREEN TEST.....	49
3.18	CALLING UP FACTORY RESET.....	49
3.19	CONNECTIVITY-SMARTPHONE APP.....	50
4	Installation.....	54
4.1	INSTALLATION PROPOSAL.....	54
4.2	DIMENSION DRAWINGS.....	57
4.3	ELECTRICAL CONNECTIONS	57
4.4	PICTOGRAPHS.....	58
5	Operating instructions.....	60
5.1	INITIAL START-UP.....	60
5.2	STARTING.....	64
5.3	STOPPING.....	66

5.4	TAKING OUT OF OPERATION.....	68
6	Maintenance.....	71
6.1	PREVENTIVE MAINTENANCE SCHEDULE.....	71
6.2	DRIVE MOTOR	73
6.3	OIL SPECIFICATIONS.....	73
6.4	OIL, FILTER AND SEPARATOR CHANGE	74
6.5	STORAGE AFTER INSTALLATION.....	76
6.6	SERVICE KITS.....	76
7	Adjustments and servicing procedures.....	77
7.1	AIR FILTER.....	77
7.2	COOLERS.....	77
7.3	DRAIN VALVE	78
7.4	BELT SET EXCHANGE AND TENSIONING	79
8	Problem solving.....	81
9	Technical data.....	83
9.1	ELECTRIC CABLE SIZE.....	83
9.2	SIZES OF FUSES.....	83
9.3	REFERENCE CONDITIONS AND LIMITATIONS.....	84
9.4	COMPRESSOR DATA.....	84

10	Instructions for use.....	88
11	Guidelines for inspection.....	89
12	Pressure equipment directives.....	90
13	Declaration of conformity.....	91

1 Safety precautions

1.1 Safety icons



DANGER

Indicates an imminently hazardous situation which, if not avoided, will result in death or serious injury.



WARNING

Indicates a potentially hazardous situation which, if not avoided, could result in death or serious injury.



NOTICE

Indicates a potential situation which, if not avoided, might result in property damage or in an undesirable result or state.



NOTE

Indicates important information.

1.2 General safety precautions

- The operator must employ safe working practices and observe all related work safety requirements and regulations.
- If any of the following statements does not comply with the applicable legislation, the stricter of the two shall apply.
- Installation, operation, maintenance and repair work must only be performed by authorized, trained, specialized personnel. The personnel should apply safe working practices by use of personal protection equipment, appropriate tools and defined procedures.
- The compressor is not considered capable of producing air of breathing quality. For air of breathing quality, the compressed air must be adequately purified according to the applicable legislation and standards.
- Before any maintenance, repair work, adjustment or any other non-routine checks, switch the controller in service mode (see section *Service mode*), stop the compressor, press the emergency stop button, switch off the voltage and depressurize the compressor. In addition, the power isolating switch must be opened and locked. The process of locking, tagging and trying to turn on the equipment to confirm it cannot operate is called Lock Out, Tag Out (LOTO).

DANGER



If the machine is equipped with an automatic restart after voltage failure function and if this function is active, be aware that the machine will restart automatically when the power is restored if it was running when the power was interrupted!

- Never play with compressed air. Do not apply the air to your skin or direct an air stream at people. Never use the air to clean dirt from your clothes. When using the air to clean equipment, do so with extreme caution and wear eye protection.
- The owner is responsible for maintaining the unit in safe operating condition. Parts and accessories shall be replaced if unsuitable for safe operation.
- It is not allowed to walk or stand on the unit or on its components.
- If compressed air is used in the food industry and more specifically for direct food contact, it is recommended, for optimal safety, to use certified Class 0 compressors in combination with appropriate filtration depending on the application. Please contact your customer center for advice on specific filtration.
- The service switch should only be operated by a trained service specialist from the manufacturer.

Safety precautions for the connectivity module

It is important to follow all regulations regarding the use of radio equipment, in particular regarding the possibility of radio frequency (RF) interference. Please follow the safety advice given below carefully.

- Respect restrictions on the use of radio equipment in fuel depots, chemical plants or other explosive environments.
- Avoid operation close to inadequately protected personal medical devices such as hearing aids and pacemakers. Consult the manufacturers of the medical device to determine if it is adequately protected.
- Avoid operation close to other electronic equipment which may also cause interference if the equipment is inadequately protected. Observe any warning signs and manufacturer recommendations.
- Respect a distance from the human body of at least 20 cm (8 inch) during operation.

1.3 Safety precautions during installation

WARNING



All responsibility for any damage or injury resulting from neglecting these precautions, or non-observance of the normal caution and care required for installation, operation, maintenance and repair, even if not expressly stated, will be disclaimed by the manufacturer.

- The machine must only be lifted using suitable equipment in accordance with the applicable safety regulations. Loose or pivoting parts must be securely fastened before lifting. It is strictly forbidden to dwell or stay in the risk zone under a lifted load. Lifting acceleration and deceleration must be kept within safe limits. Wear a safety helmet when working in the area of overhead or lifting equipment.
- The unit is designed for indoor use. If the unit is installed outdoors, special precautions must be taken. Consult your supplier.
- Place the machine where the ambient air is as cool and clean as possible. If necessary, install a suction duct. Never obstruct the air inlet. Care must be taken to minimize the entry of moisture at the inlet air.
- Any blanking flanges, plugs, caps and desiccant bags must be removed before connecting the pipes.

- Air hoses must be of correct size and suitable for the working pressure. Never use frayed, damaged or worn hoses. Distribution pipes and connections must be of the correct size and suitable for the working pressure.
- The aspirated air must be free of flammable fumes, vapors and particles, e.g. paint solvents, that can lead to internal fire or explosion.
- Arrange the air intake so that loose clothing worn by people cannot be drawn in.
- Ensure that the discharge pipe from the compressor to the after-cooler or air net is free to expand under heat and that it is not in contact with or close to flammable materials.
- No external force may be exerted on the air outlet valve; the connected pipe must be free of strain.
- If remote control is installed, the machine must bear a clear sign stating: DANGER: This machine is remotely controlled and may start without warning.

The operator has to make sure that the machine is stopped and depressurized and that the electrical isolating switch is open, locked and labelled with a temporary warning before any maintenance or repair. As a further safeguard, persons switching on or off remotely controlled machines shall take adequate precautions to ensure that there is no one checking or working on the machine. To this end, a suitable notice shall be affixed to the start equipment.

- Air-cooled machines must be installed in such a way that an adequate flow of cooling air is available and that the exhausted air does not recirculate to the compressor air inlet or cooling air inlet.
- The electrical connections must correspond to the applicable codes. The machines must be earthed and protected against short circuits by fuses in all phases. A lockable power isolating switch must be installed near the compressor.
- On machines with automatic start/stop system or if the automatic restart function after voltage failure is activated, a sign stating "This machine may start without warning" must be affixed near the instrument panel.
- In multiple compressor systems, manual valves must be installed to isolate each compressor. Non-return valves (check valves) must not be relied upon for isolating pressure systems.
- Never remove or tamper with the safety devices, guards or insulation fitted on the machine. Every pressure vessel or auxiliary installed outside the machine to contain air above atmospheric pressure must be protected by a pressure relieving device or devices as required.
- Piping or other parts with a temperature in excess of 70°C (158°F) and which may be accidentally touched by personnel in normal operation must be guarded or insulated. Other high temperature piping must be clearly marked.
- If the ground is not level or can be subject to variable inclination, consult the manufacturer.
- In an installation with multiple compressors, the outlet piping must be installed in such a way that condensate cannot flow back into the compressor. See section *Installation proposal*.

NOTE



Also consult the following safety precautions: *Safety precautions during operation* and *Safety precautions during maintenance or repair*.

These precautions apply to machinery processing or consuming air or inert gas. Processing of any other gas requires additional safety precautions typical to the application which are not included herein.

Some precautions are general and cover several machine types and equipment; hence some statements may not apply to your machine.

1.4 Safety precautions during operation

WARNING



All responsibility for any damage or injury resulting from neglecting these precautions, or non-observance of the normal caution and care required for installation, operation, maintenance and repair, even if not expressly stated, will be disclaimed by the manufacturer.

- Never touch any piping or components of the machine during operation.
- Use only the correct type and size of hose end fittings and connections. When blowing through a hose or air line, ensure that the open end is held securely. A free end will whip and may cause injury. Make sure that a hose is fully depressurized before disconnecting it.
- Persons switching on remotely controlled machines shall take adequate precautions to ensure that there is no one checking or working on the machine. To this end, a suitable notice shall be affixed to the remote start equipment.
- Never operate the machine when there is a possibility of taking in flammable or toxic fumes, vapors or particles.
- Never operate the machine below or in excess of its limit ratings.
- Keep all bodywork doors shut during operation. The doors may be opened for short periods only, e.g. to carry out routine checks. Wear ear and eye protection when opening a door.

On machines without bodywork, wear ear protection in the vicinity of the machine.

- People staying in environments or rooms where the sound pressure level reaches or exceeds 80 dB(A) shall wear ear protectors.
- Periodically check that:
 - All guards are in place and securely fastened
 - All hoses and/or pipes inside the machine are in good condition, secure and not rubbing
 - No leaks occur
 - All fasteners are tight
 - All electrical leads are secure and in good order
 - Safety valves and other pressure relief devices are not obstructed by dirt or paint
 - Air outlet valve and air net, i.e. pipes, couplings, manifolds, valves, hoses, etc. are in good repair, free of wear or abuse
 - All pre-filters are not clogged
- If warm cooling air from compressors is used in air heating systems, e.g. to warm up a workroom, take precautions against air pollution and possible contamination of the breathing air.
- Do not remove any of, or tamper with, the sound-damping material.
- Never remove or tamper with the safety devices, guards or insulations fitted on the machine. Every pressure vessel or auxiliary installed outside the machine to contain air above atmospheric pressure shall be protected by a pressure relieving device or devices as required.
- Yearly inspect the air receiver. Minimum wall thickness as specified in the instruction book must be respected. Local regulations remain applicable if they are more strict.



NOTE

Also consult the following safety precautions: *Safety precautions during operation* and *Safety precautions during maintenance or repair*.

These precautions apply to machinery processing or consuming air or inert gas. Processing of any other gas requires additional safety precautions typical to the application which are not included herein.

Some precautions are general and cover several machine types and equipment; hence some statements may not apply to your machine.

1.5 Safety precautions during maintenance or repair

WARNING



All responsibility for any damage or injury resulting from neglecting these precautions, or non-observance of the normal caution and care required for installation, operation, maintenance and repair, even if not expressly stated, will be disclaimed by the manufacturer.

- Always use the correct safety equipment (such as safety glasses, gloves, safety shoes, etc.).
- Use only the correct tools for maintenance and repair work.
- Use only genuine spare parts for maintenance or repair. The manufacturer will disclaim all damage or injuries caused by the use of non-genuine spare parts.
- All maintenance work shall only be undertaken when the machine has cooled down.
- A warning sign bearing a legend such as "Work in progress; do not start" shall be attached to the starting equipment.
- Persons switching on remotely controlled machines shall take adequate precautions to ensure that there is no one checking or working on the machine. To this end, a suitable notice shall be affixed to the remote start equipment.
- Close the compressor air outlet valve and depressurize the compressor before connecting or disconnecting a pipe.
- Before removing any pressurized component, effectively isolate the machine from all sources of pressure and relieve the entire system of pressure. See section *Maintenance*.
- Never use flammable solvents or carbon tetrachloride for cleaning parts. Take safety precautions against toxic vapors of cleaning liquids.
- Scrupulously observe cleanliness during maintenance and repair. Keep dirt away by covering the parts and exposed openings with a clean cloth, paper or tape.
- Never weld or perform any operation involving heat near the oil system. Oil tanks must be completely purged, e.g. by steam cleaning, before carrying out such operations. Never weld on, or in any way modify, pressure vessels.
- Whenever there is an indication or any suspicion that an internal part of a machine is overheated, the machine shall be stopped but no inspection covers shall be opened before sufficient cooling time has elapsed; this to avoid the risk of spontaneous ignition of the oil vapor when air is admitted.
- Never use a light source with open flame for inspecting the interior of a machine, pressure vessel, etc.
- Make sure that no tools, loose parts or rags are left in or on the machine.
- When replacing the air filter, make sure no dirt, dust, rags, tools or loose parts can fall in the air inlet.
- All regulating and safety devices shall be maintained with due care to ensure that they function properly. They may not be put out of action.

- Before clearing the machine for use after maintenance or overhaul, check that operating pressures, temperatures and time settings are correct. Check that all control and shut-down devices are fitted and that they function correctly. If removed, check that the coupling guard of the compressor drive shaft has been reinstalled.
- Every time the separator element is renewed, examine the discharge pipe and the inside of the oil separator vessel for carbon deposits; if excessive, the deposits should be removed.
- Protect the motor, air filter, electrical and regulating components, etc. to prevent moisture from entering them, e.g. when steam cleaning.
- Make sure that all sound-damping material and vibration dampers, e.g. damping material on the bodywork and in the air inlet and outlet systems of the compressor, is in good condition. If damaged, replace it by genuine material from the manufacturer to prevent the sound pressure level from increasing.
- Never use caustic solvents which can damage materials of the air net, e.g. polycarbonate bowls.
- **Only if applicable, the following safety precautions are stressed when handling refrigerant:**
 - Never inhale refrigerant vapors. Check that the working area is adequately ventilated; if required, use breathing protection.
 - Always wear special gloves. In case of refrigerant contact with the skin, rinse the skin with water. If liquid refrigerant contacts the skin through clothing, never tear off or remove the latter; flush abundantly with fresh water over the clothing until all refrigerant is flushed away; then seek medical first aid.
- Protect hands to avoid injury from hot machine parts, e.g. during draining of oil.
- Be aware of eventual sharp edges on certain parts of the machine.

NOTE

Also consult the following safety precautions: *Safety precautions during operation* and *Safety precautions during maintenance or repair*.



These precautions apply to machinery processing or consuming air or inert gas. Processing of any other gas requires additional safety precautions typical to the application which are not included herein.

Some precautions are general and cover several machine types and equipment; hence some statements may not apply to your machine.

1.6 Dismantling and disposal

The device must be disposed according to local regulations. The product is not designed for refurbishing after finished lifecycle.

Dismantling

Once the end of life of the machine is reached, please follow next steps:

1. Stop the machine.
2. Check all safety precautions mentioned in the previous chapters to secure safe handling (e.g. LOTO, cool-down, depressurize, discharge, etc.).
3. Have trained personnel dismantle the installation.
4. Separate the harmful from the safe components (e.g. drain oil from parts containing oil).

5. Refer to the disposal topic below.

Disposal of electrical and electronic appliances (WEEE)

This equipment falls under the provisions of the European Directive 2012/19/EU on waste electrical and electronic appliances (WEEE) as well as under the UKCA Waste Electrical and Electronic Equipment regulations 2013 and may not be disposed as unsorted waste.



The equipment is labelled in accordance with the European Directive 2012/19/EU and the UKCA Waste Electrical and Electronic Equipment regulations 2013 with the crossed-out wheellie bin symbol.

At the end of life-time of the electric and electronic equipment (EEE) it must be taken to separate collection.

For more information check with your local waste authority, customer center or distributor.

Disposal of other used material

Used filters or any other used material (e.g. filter bags, filter media, desiccant, lubricants, cleaning rags, machine parts, etc.) must be disposed of in an environmentally friendly and safe manner, and in line with the local recommendations and environmental legislation.

2 General description

2.1 Introduction

Introduction

G 2 VSD, G 3 VSD, G 4 VSD, G 5 VSD and G 7 VSD are air-cooled, single-stage, oil-injected screw compressors, driven by an electric motor.

The compressors are belt driven and use Variable Speed Drive (VSD) technology that adjusts the motor speed automatically depending on the compressed air demand.

The compressors are enclosed in sound-insulating bodywork.

An easy-to-operate control panel is provided, including the electronic controller and the emergency stop button. A cabinet housing the controller, pressure sensor and motor starter is integrated into the bodywork.

Pack versions do not include an air dryer.

Full-Feature versions are fitted with an air dryer (DR). The dryer removes moisture from the compressed air by cooling the air to near the freezing point and automatically draining the condensate.

Floor-mounted model

Floor-mounted units are installed directly on the floor and are available as a Pack and Full-Feature version.



Figure 1: Floor-mounted, Pack

Reference	Description
1	Electrical cabinet
ER	Controller
S3	Emergency stop button



Figure 2: Floor-mounted, Full-Feature

Reference	Description
1	Electrical cabinet
ER	Controller
S3	Emergency stop button

Tank-mounted model

Tank-mounted units are supplied with an air receiver of 200 l (52.80 US gal / 44 Imp gal / 7 cu.ft) and are available as a Pack and Full-Feature version.



Figure 3: Tank-mounted, Pack

Ref.	Description
1	Electrical cabinet
ER	Controller
S3	Emergency stop button
AO	Air outlet
AR	Air receiver
Dm2	Manual condensate drain valve, air receiver
SV	Safety valve

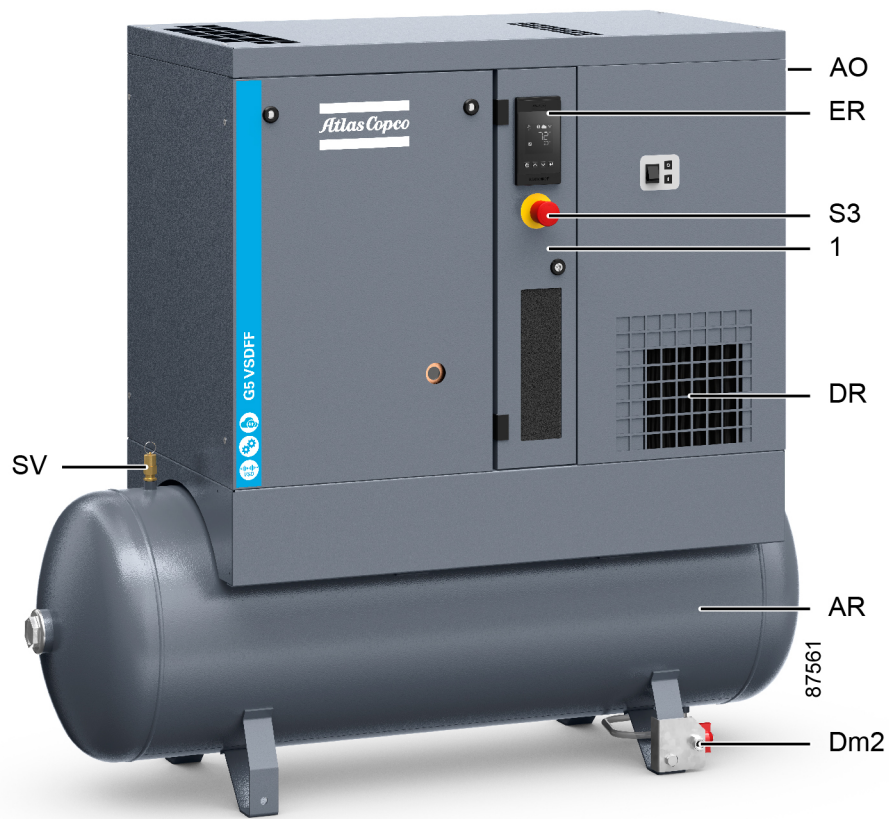

Figure 4: Tank-mounted, Full-Feature

Ref.	Description
1	Electrical cabinet
ER	Controller
S3	Emergency stop button
AO	Air outlet
AR	Air receiver
Dm2	Manual condensate drain valve, air receiver
SV	Safety valve
DR	Integrated dryer

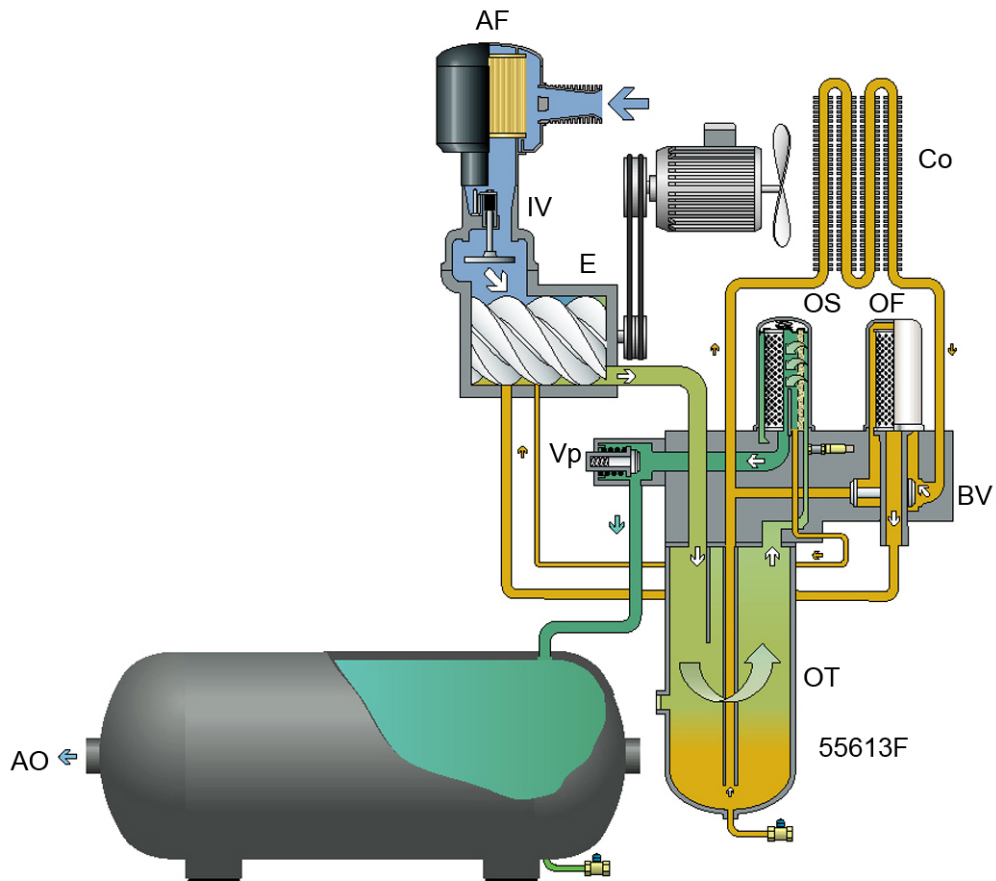

Figure 6: Tank-mounted, Pack units

Air drawn in through the air filter (AF) and the open inlet valve (IV) is compressed in the compressor element (E). Compressed air and oil flow into the oil separator/tank (OT) where most of the oil is removed by centrifugal action. The remaining oil is removed by the oil separator (OS). The air flows to the outlet (AO) via the minimum pressure valve (Vp).

Full-Feature

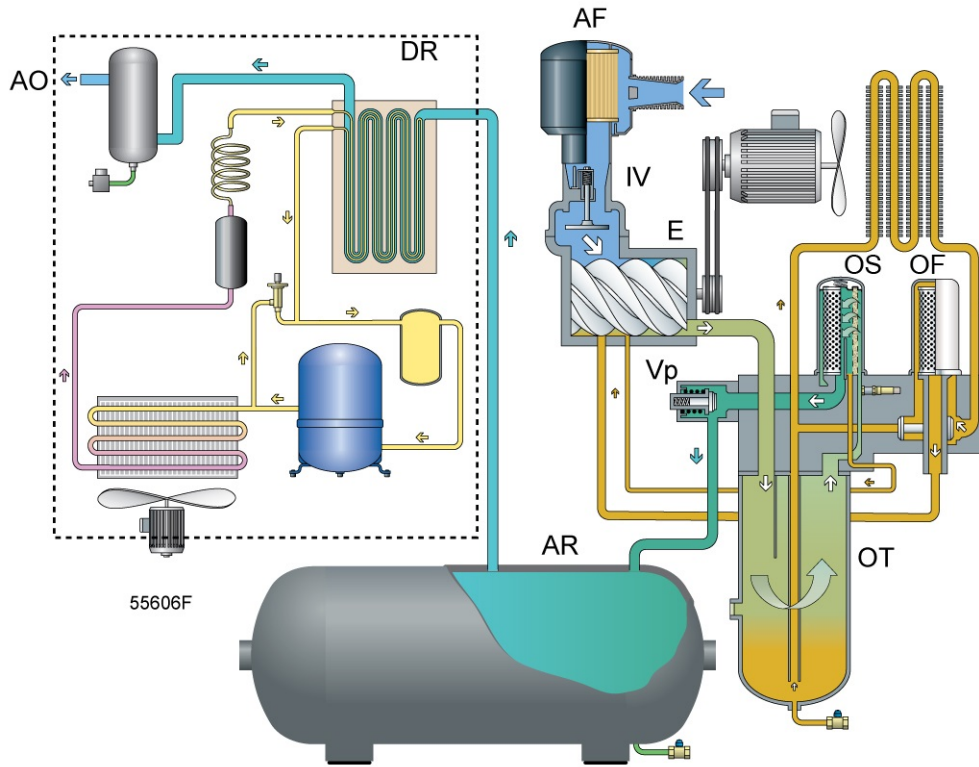

Figure 7: Tank-mounted, Full-Feature units

Air drawn in through the air filter (AF) and the open inlet valve (IV) is compressed in the compressor element (E). Compressed air and oil flow into the oil separator/tank (OT) where most of the oil is removed by centrifugal action. The remaining oil is removed by the oil separator (OS). The air is discharged via the minimum pressure valve (Vp), the air receiver (AR) and the dryer (DR) towards the air outlet (AO).

2.3 Oil system

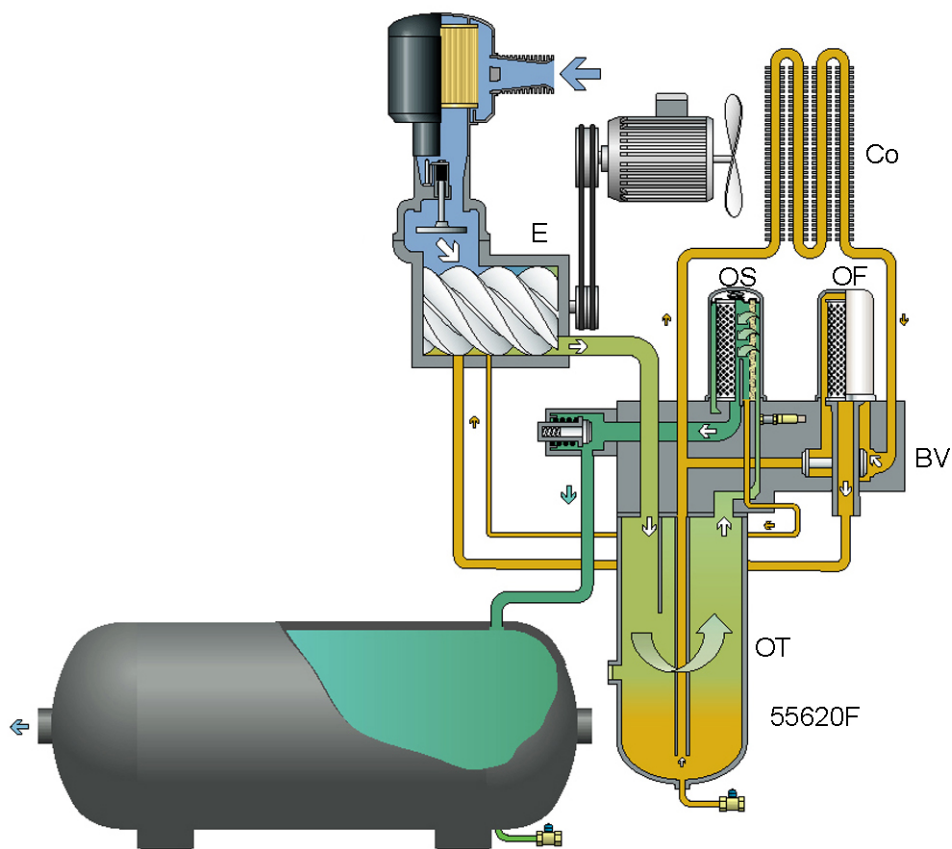

Figure 8: Pack

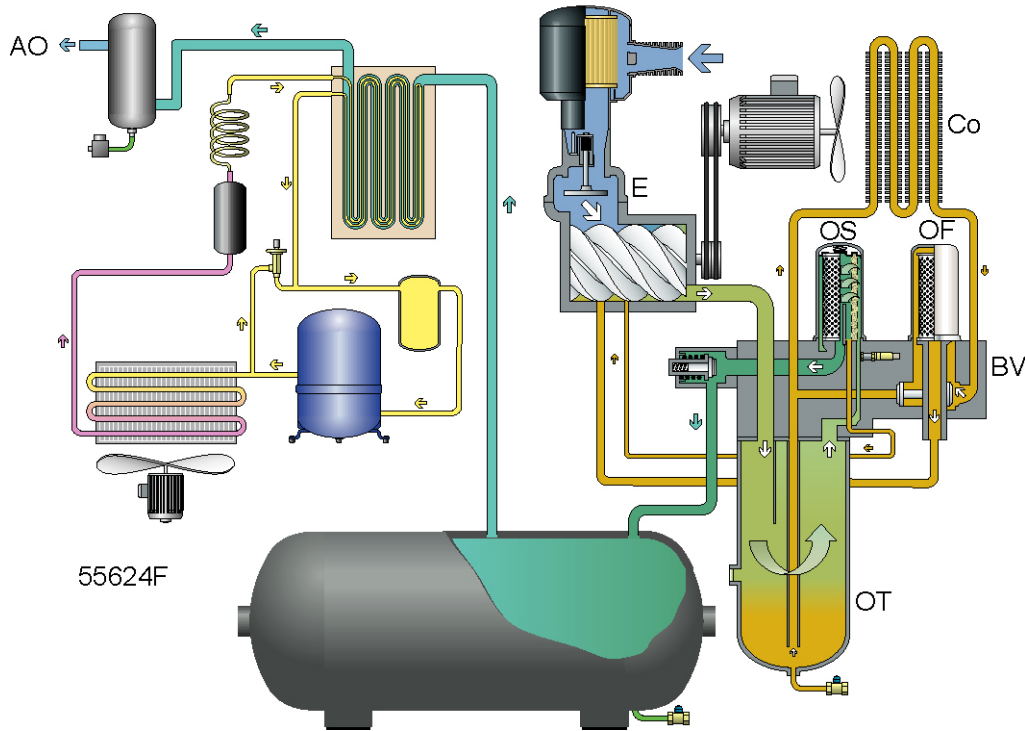

Figure 9: Full-Feature

The air pressure in the oil separator tank (OT) forces the oil from the tank to the compressor element (E) via the oil cooler (Co) and the oil filter (OF). Compressed air and oil flow into the oil separator/tank (OT) where most of the oil is separated from the air by centrifugal action. The remaining oil is removed by the oil separator (OS) and returns to the oil circuit via a separate line. The minimum pressure valve ensures a minimal pressure in the tank, required for oil circulation under all circumstances. See section *Air flow*.

The oil circuit has a thermostatic bypass valve (BV). When the oil temperature is below the set point of the valve, the bypass valve shuts off the oil supply from the oil cooler. The bypass valve starts opening the supply from the cooler (Co) when the oil temperature exceeds the setting of the valve. The setting of the bypass valve depends on the model. See section *Compressor data*.

There might be formation of condensation in the oil separator vessel, especially if the unit is oversized or in an environment with high relative humidity. If necessary, the condensation must be checked and removed on a regular basis through the manual drain valve to prevent water-related damage on the components of the oil circuit. See section *Preventive maintenance schedule*.

2.4 Cooling system

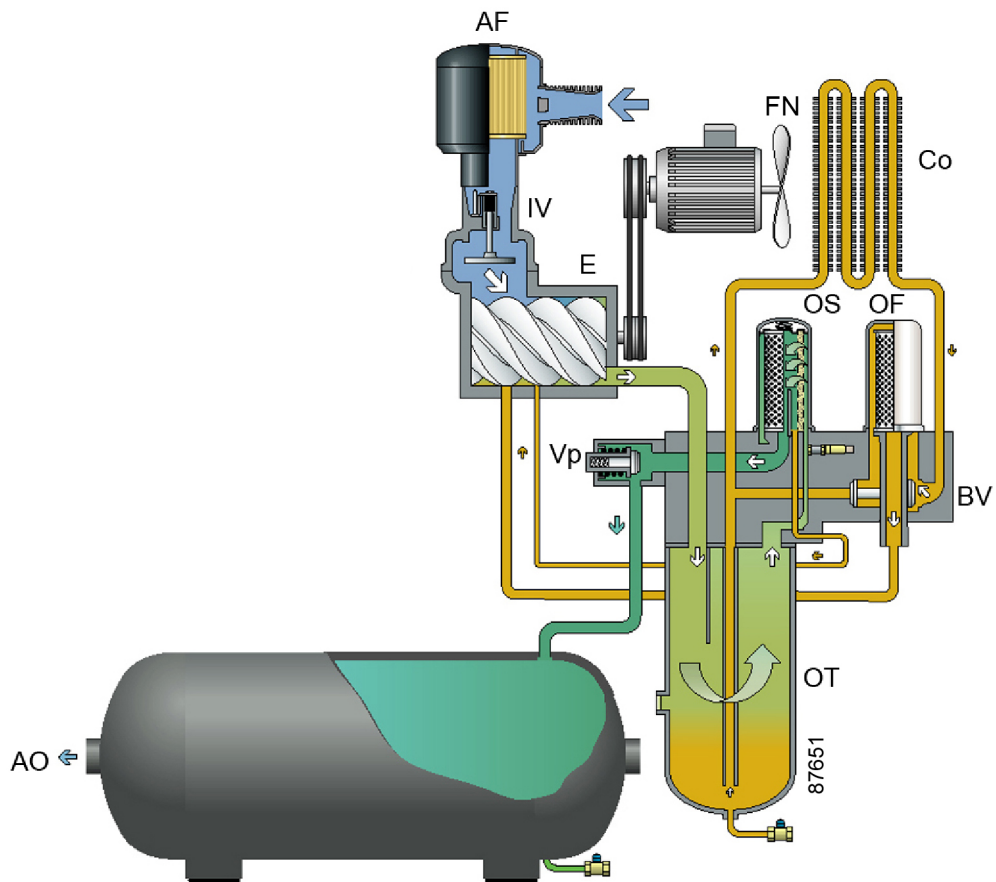

Figure 10: Pack

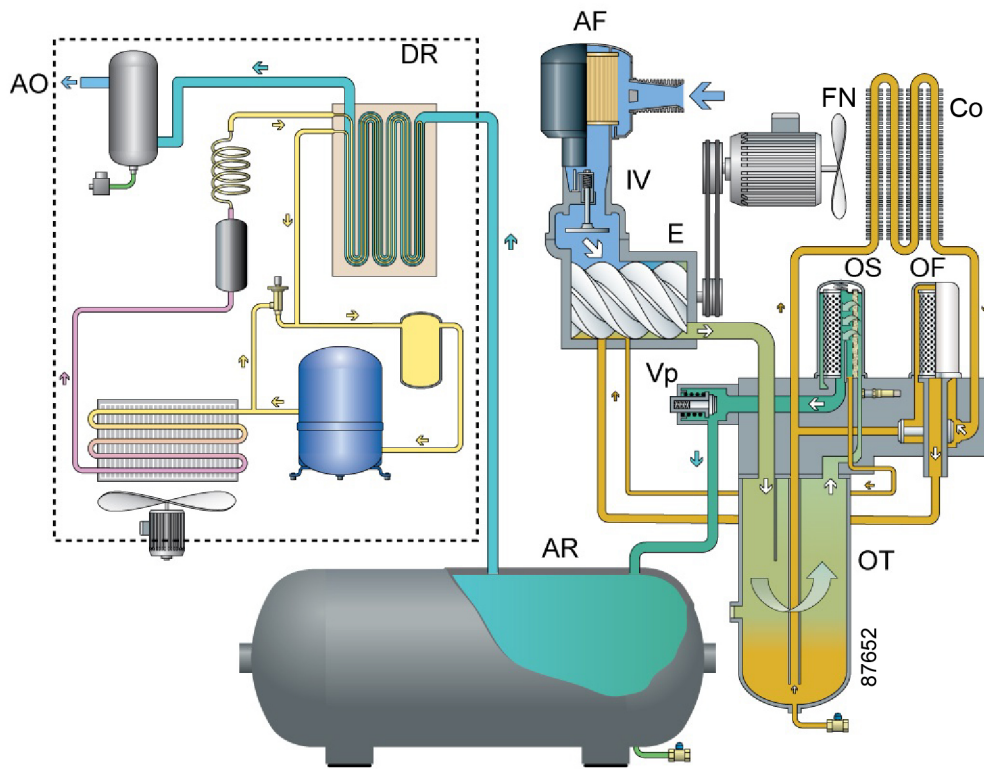
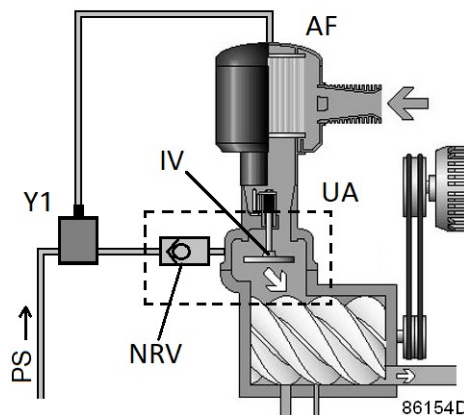

Figure 11: Full-Feature

The cooling system of the Pack version comprises the oil cooler (Co) and fan (FN). The fan, mounted directly onto the motor shaft, generates the air that cools the oil and the internal parts of the compressor. On tank-mounted compressors, the air receiver is used as air cooler. The condensate must be drained manually on a regular basis, see section *Preventive maintenance schedule*.

The dryer (DR) of Full-Feature versions has a separate cooling fan and an automatic condensate drain. See section *Air dryer*.

2.5 Regulating system



The main components of the regulating system are:

- The unloader (UA), including the inlet valve (IV) and the non-return valve (NRV).

- The loading solenoid valve (Y1), normally open.
- The pressure signal (PS) from the instrument block.
- The controller that regulates the compressor based on the pressure settings and readings of the pressure sensor.

Description

When the compressor is started and the net pressure is below the set point (desired net pressure), the motor speed increases until the net pressure reaches the set point or until the maximum motor speed is reached. If the air consumption is less than the air delivery of the compressor, the net pressure increases further.

When the net pressure reaches the set point and continues to rise, the regulator decreases the motor speed. When the pressure continues to increase, even though the motor already operates at minimum speed, the regulator will close the inlet valve (IV) and the compressor will run in unloading condition as soon as the net pressure reaches a value equal to the set point plus the indirect stop level (typically 0.5 bar above the set point). If the pressure does not drop below the set point after 30 seconds of running unloaded, the regulator will stop the main motor.

If the compressor was stopped in automatic operation and the net pressure approaches the set point, the regulator starts the motor again. The quicker the net pressure drops, the quicker the compressor will restart. Should the net pressure rise very quickly to a value equal to the set point plus the direct stop level (typically 1 bar above the set point), the compressor is stopped immediately (without first decreasing the motor speed). See section *Calling up/ modifying pressure band settings*.

2.6 Control panel



Figure 12: Electrical cabinet

Reference	Description
1	Electrical cabinet
ER	Controller

Reference	Description
S3	Emergency stop button

2.7 Electrical system

Electrical components

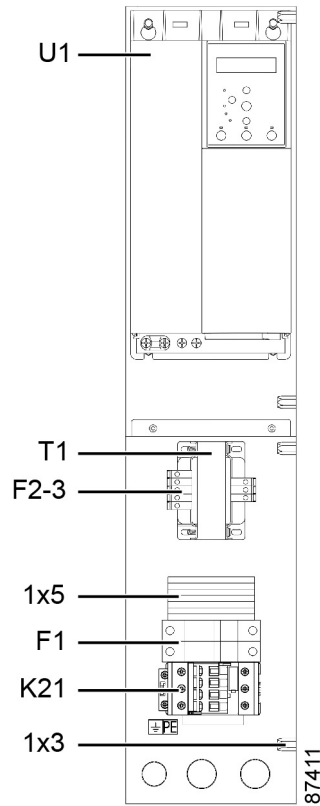

Figure 13: Electrical cabinet

Reference	Description
F1-3	Fuses
U1	Frequency converter
K21	Line contactor
T1	Transformer
1x3	Terminal block of the earth protection
1x5	Terminal block of the control unit

Electrical diagram

Diagram number	Description
2205 0188 00	G 2-7 VSD IEC
2205 0372 00	G 2-7 VSD UL

The complete electrical diagram can be found in the technical documentation supplied with the machine.

2.8 Protection of the compressor

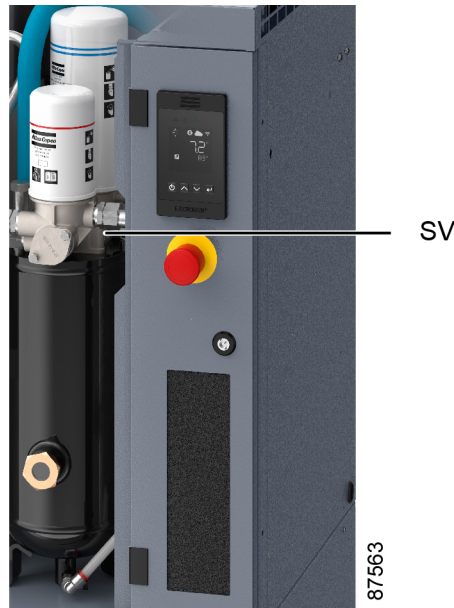

Figure 14: Safety valve on the compressor

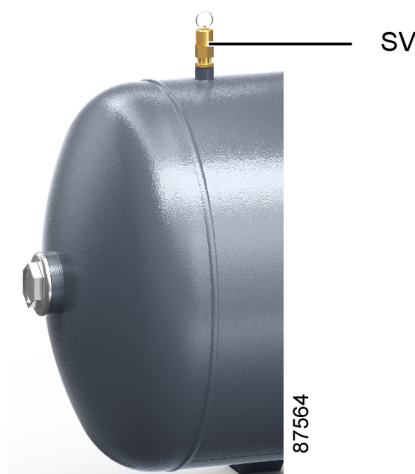
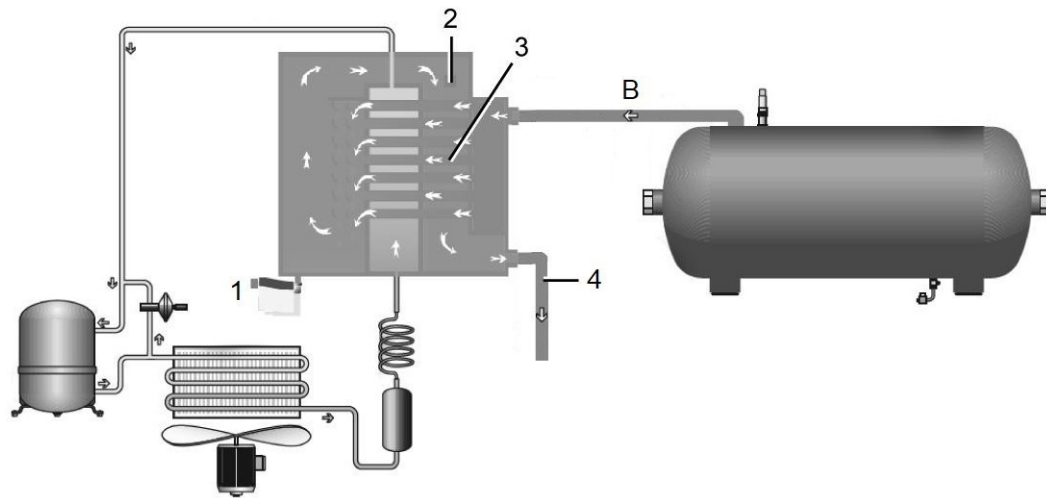

Figure 15: Safety valve on the air receiver, tank-mounted units

Reference	Description	Function
SV	Safety valve	Protects the air outlet system if the outlet pressure exceeds the opening pressure of the valve.

2.9 Air dryer



86127D

Figure 16: Air Dryer

Wet compressed air (B) enters the dryer. The air then flows through the heat exchanger (2) where the refrigerant evaporates, withdrawing heat from the air. The cold air then flows through a condensate trap (1) which separates the condensate from the air. The condensate is drained automatically. The cold, dried air then flows through the heat exchanger (3), where it is warmed up by the incoming air, and finally discharged from the dryer outlet (4).

3 Controller

3.1 Controller functions



Figure 17: Elektronikon® Nano™ controller

Introduction

The controller has the following functions:

- Controlling the unit
- Protecting the unit
- Monitoring components subject to service
- Automatic restart after voltage failure (ARAVF)
- Integrated connectivity (Bluetooth 4.2, Wi-Fi 802.11 b/g/n or Ethernet RJ45)

Automatic control of the unit

The controller maintains the net pressure at the programmable set point by adapting the motor speed and automatically loading and unloading the unit.

A number of programmable settings, e.g. the unloading and loading pressures, the minimum stop time and the maximum number of motor starts are taken into account.

The controller stops the unit whenever possible to reduce the power consumption and restarts it automatically when the net pressure decreases. If the expected unloading period is too short, the unit is kept running to prevent too short standstill periods.

WARNING

A number of time-based automatic start/stop commands may be programmed. Take into account that a start command will be executed (if programmed and activated), even after manually stopping the unit.

Protecting the unit**Shutdown**

If the outlet element temperature exceeds the programmed shutdown level, the unit will be stopped. This will be indicated on the display of the controller.

The unit will also be stopped in case of overload of the drive motor.

WARNING

Before remedying, consult the safety precautions.

Before resetting a warning or shutdown message, an authorized technician should solve the problem. If a warning or alarm persists to occur, consult your supplier. Frequently resetting these messages without remedying may damage the unit.

Warning

A warning level is a level below the shutdown level.

If one of the measurements exceeds the programmed warning level, a message will appear on the display and the general alarm LED will light up to warn the operator before the shutdown level is reached.

The message disappears as soon as the warning condition disappears.

Service warning

If the service timer exceeds a programmed value, this will be indicated on the display to warn the operator to carry out the service actions.

WARNING

Ignoring this service warning could severely damage your machine in the long term. The supplier is not liable for failures caused by neglecting service interval timings.

Automatic restart after voltage failure (ARAVF)

The machine is designed to not lead to hazardous situations after a power voltage failure (according to safety standards). However, if required, the ARAVF function can be activated in the Smartphone App (see section *Connectivity-Smartphone App*).

This function, when enabled, will automatically restart the unit when the voltage is restored after voltage failure. This function is deactivated in the unit before leaving the factory.

The activation of ARAF function at customer side, will automatically release your supplier from any legal responsibility related to damages or injuries related to things and persons related to its activation and use. For this reason due to the safety implications of this function it will be required that, before activating it, every responsible of the machine signs a declaration, which exempts your

supplier from every liability. The danger is due to the fact that the machine is remote controlled and could start running without any notice. This could lead to eventual damage of the electrical plant and personal damage.

Please make sure to train adequately, the personnel in charge of the unit start up, in order to be sure that before starting the unit, nobody is working close to the machine. And if maintenance is necessary that the proper Lock out, tag out (LOTO) procedure is followed (see section *General safety precautions*).

WARNING



If the function is activated and provided the regulator was in the automatic operation mode, the unit will automatically restart if the supply voltage to the module is restored. The ARAVF label shall be attached near to the controller.

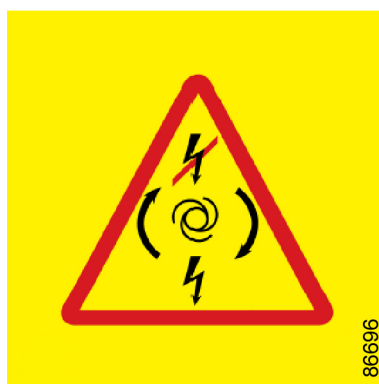

Figure 18: ARAVF label

The ARAVF label is attached on the side panel, next to the controller, with the goal of warning users of the risks linked to the function.

Integrated connectivity

Integrated connectivity allows you to monitor and control the unit by using just your smartphone. Use the application to check the real-time performance indicator like pressure, temperature, running hours and operation mode. Receive real time notification of warnings and shutdown.

Control the unit remotely with following functions:

- Start and stop the unit
- Set unload and load pressure
- Select your required pressure bands to enhance performance and save energy
- Set up your week timer

WARNING



As a further safeguard, persons switching on or off remotely controlled machines shall take adequate precautions to ensure that there is no one checking or working on the machine. To this end, a suitable notice shall be affixed to the start equipment. See section *Service mode*.

3.2 Control panel

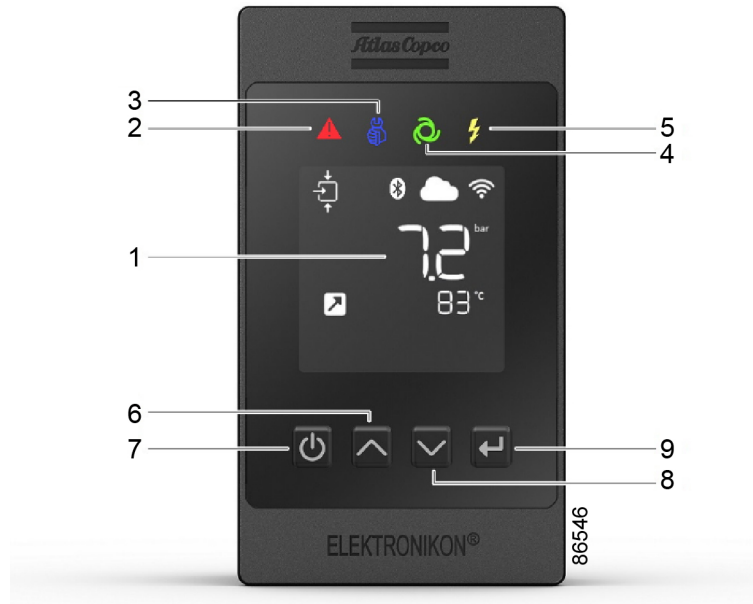

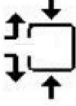
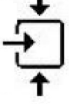





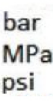

















Figure 19: Control panel

Reference	Designation	Function
1	Display	Shows the unit operating condition and a number of icons to navigate through the menu.
2	Warning sign	Flashes in case of a shutdown, is lit in case of a warning condition.
3	Service sign	Is lit when service is needed and flashing when the unit is in service mode.
4	Operation sign	Is lit when the unit is running in automatic operation.
5	Voltage sign	Indicates that the voltage is switched on.
6	Up button	Use these buttons to scroll through the menu.
7	Start/stop button	This button starts the unit. The operation sign (4) lights up. The controller is operative. This button also stops the unit at next pressing.
8	Down button	Use these buttons to scroll through the menu.
9	Enter button	Use this button to confirm the last action or reset the alarm.

3.3 Icons used

Status icons

Icon	Description
 86547	Motor stopped
 86548	Running unloaded
 86549	Running loaded
 86550	On: Remote Machine Control Mode, active: compressor can start from Bluetooth or via external switch if wired.
 86551	Automatic Restart After Voltage Failure, active
 86552	Emergency stop
 86553	Main motor
 86554	Element outlet temperature
 86555	Units of pressure, outlet
 86556	Units of temperature, outlet
 86557	Dryer
 86558	Units of dryer LAT temperature (Low ambient temperature)

Icon	Description
 86559	Multiply value x1000
 86560	Value in hours
 86561	Value in seconds
 86562	Fixed: Week timer, active Blinking: Waiting
 86563	Fixed: LAN cable connected Blinking: LAN cable not connected
 86564	Bluetooth connection: appears only when controller is paired to the app through Bluetooth.
 86565	Wi-Fi signal 100%
 86566	Wi-Fi signal 75%
 86567	Wi-Fi signal 50%
 86568	Wi-Fi signal 25%
 86569	Cloud connected
 86570	Fixed: Over-the-air (OTA) update available Blinking: Over-the-air (OTA) update in progress



NOTE

This chapter gives a general survey of available icons. Not all icons mentioned in this chapter are applicable to every machine.

3.4 Main screen

When the voltage is switched on, the first screen is a test screen. The next screen is the Main screen, shown automatically:



The Main screen shows:

- The unit status by means of pictographs
- The air outlet pressure
- The element outlet temperature

The screen backlight stays on for 2 minutes (default setting), to turn on the backlight again, press any key on the controller.

The screen reactivates when you approach the unit with a connected smartphone.

In case of warning or shutdown the backlight will light up automatically.

3.5 Warning

Description

A warning will appear in the following circumstances:

- The temperature is too high at the outlet of the compressor's element (TT11).
- The temperature is too low at the outlet of the compressor's element (TT11).

If the unit is connected to the Cloud (internet connection), you will receive a real-time warning notification.

Compressor element outlet temperature (TT11)

If the outlet temperature of the compressor's element exceeds the warning level warning (factory setting 110 °C / 230 °F) LED (2) will light up red:



Figure 20: Main screen with temperature outlet warning

The related pictograph



will appear flashing with the temperature unit °C / °F icon.

- It remains possible to scroll through other screens, using the scroll buttons up and down (6 and 8) to check the actual status of other parameters.
- Press the button (7) to stop the compressor and wait until the compressor has stopped.
- Switch off the voltage, inspect the compressor and troubleshoot. Before solving the issue, consult section *Safety precautions*.
- The warning message will disappear as soon as the warning condition disappears.

3.6 Shutdown

Description

The unit will be shut down in the following circumstances:

- The outlet temperature exceeds the shutdown level detected by temperature sensor (TT11) or temperature switches (TSHH11- TSHH21).
- There is an error of the outlet pressure (PT20) /temperature sensor (TT11).
- The outlet pressure too high.
- Frequency converter (U1) fault.

If the unit is connect to the Cloud, you will receive a real-time shutdown notification.

Compressor element outlet temperature

If the outlet temperature of the compressor element exceeds the shutdown level (factory setting 115 °C / 239 °F), the compressor will shut down, the alarm LED (2) will flash, the automatic operation LED (4) will go out and the following screen will appear:



Figure 21: Main screen with temperature outlet shutdown

The related pictograph



will appear flashing with temperature unit °C / °F icon.

Press the scroll buttons (6-8) until the actual compressor element temperature appears.

The screen shows that the temperature at the outlet of the compressor element is 117 °C.

- Switch off the voltage and troubleshoot. Before solving the issue, consult section *Safety precautions*.
- When the issue is solved and the shutdown condition has disappeared, switch on the voltage and restart the unit.

Compressor element outlet temperature by temperature switch (TSHH11 / TSHH21)

If the outlet temperature of the compressor element triggers the temperature switch, the compressor will shut down, the alarm LED (2) will flash, the automatic operation LED (4) will go out and the following screen will appear:



Figure 22: Main screen with temperature switch shutdown

The related pictograph



will appear flashing.

Error pressure/temperature sensor

In case of an error of the outlet pressure sensor (PT20) or temperature sensor (TT11), the compressor will shut down. The following screen will appear:



Figure 23: Error on pressure and temperature sensor

Compressor outlet pressure too high

If the outlet pressure of the compressor exceeds the shutdown level (factory setting 1.5 bar / 22 psi over the maximum pressure of compressor) the compressor will be shutdown, the alarm LED (2) will flash, the automatic operation LED (4) will go out and the following screen will appear:



Figure 24: High outlet pressure

The unit of pressure bar/psi/MPa will appear flashing.

- Switch off the voltage and remedy the trouble. Before remedying, consult section *Safety precautions*.
- After remedying and when the shutdown condition has disappeared, switch on the voltage and restart the unit.

Frequency converter fault

In the event of a frequency converter fault, the compressor will shut down, the alarm LED (2) will flash, the automatic operation LED (4) will go out and the following screen will appear:



Figure 25: Main screen with shutdown indication, frequency converter fault

- Switch off the voltage and troubleshoot. Before solving the issue, consult section *Safety precautions*.
- When the issue is solved and the shutdown condition has disappeared, switch on the voltage and restart the unit.

If the frequency converter alarm reset does not work:

- Disconnect the unit from the power supply for 15 minutes.
- After the power is restored, reset the frequency converter alarm on the controller. If the problem is not solved, please contact the manufacturer's technical support.

Frequency converter fault number	Control alarm code	Fault text	Warning	Alarm	Trip locked	Cause
2	2	Live zero error	X	X		Signal on terminal 53 is too low.
4	4	Line power ph. loss	X	X	X	Missing phase on supply side or voltage imbalance too high. Check supply voltage.
7	80	DC over volt	X	X		Intermediate circuit voltage exceeds the limit.
8	100	DC under volt	X	X		Intermediate circuit voltage drops below the "voltage warning low" limit.
9	200	Inverter overload	X	X		More than 100% load for too long.
10	400	Motor ETR over	X	X		Motor is too hot due to more than 100% load for too long.

Frequency converter fault number	Control alarm code	Fault text	Warning	Alarm	Trip locked	Cause
11	800	Motor th over	X	X		The thermistor or the thermistor connection is disconnected. (Where thermistors are present.)
13	1000	Overcurrent	X	X	X	Inverter peak current limit is exceeded.
14	4000	Ground Fault		X	X	Discharge from output phases to ground.
16	10000	Short-circuit		X	X	Short-circuit in the motor or on the motor terminals.
17	20000	Ctrl. word TO	X	X		No communication to the adjustable frequency drive.
24	1000000	Fan fault	X	X		The fan is not working (only on 400 V 40–1 25 hp [30–90 kW] units).
30	40000000	U phase loss		X	X	Motor phase U is missing. Check the phase.
31		V phase loss		X	X	Motor phase V is missing. Check the phase.
32		W phase loss		X	X	Motor phase W is missing. Check the phase.
38		Internal fault		X	X	Contact compressor service.
44		Ground fault		X	X	Discharge from output phases to ground.
47		Control voltage fault	X	X	X	24 V DC may be overloaded.
48		VDD1 supply low		X	X	Control voltage low. Contact compressor service.
50		Calibration failed		X		Contact compressor service.
51		Unom, inom		X		The setting of motor voltage, motor current and motor power is presumably wrong.
52		low inom		X		The motor current is too low.
53		Big motor		X		The motor is too big for the reset to be carried out.
54		Small mot		X		The motor is too small for the reset to be carried out.
55		Par. range		X		The parameter values found from the motor are outside acceptable range.
56		User interrupt		X		The running has been interrupted by the user.

Frequency converter fault number	Control alarm code	Fault text	Warning	Alarm	Trip locked	Cause
57		Timeout		X		Try to start the unit again a number of times. NOTE! Repeated runs may heat the motor to a level where the resistance Rs and Rr are increased. In most cases, however, this is not critical.
58		Internal	X	X		Contact compressor service.
59		Current limit	X			The current is higher than the value in the current limit.
60		External interlock		X		External interlock has been activated. To resume normal operation, apply 24 V DC to the terminal programmed for external interlock and reset the adjustable frequency drive (via serial communication, digital I/O, or by pressing reset button on keypad).
66		Heat sink temperature low	X			This warning is based on the temperature sensor in the IGBT module (only on 400 V 40–125 hp [30–90 kW] units).
69		Pwr. card temp	X	X	X	The temperature sensor on the power card is either too hot or too cold. In case that it is too hot, clean the filter on the cubicle door.
79		Illegal power section configuration	X	X		Internal fault. Contact your supplier.
80		Drive initialized		X		All parameter settings are initialized to default settings.
87		Auto DC braking	X			The drive is auto DC braking.

3.7 Service warning

A service warning will appear when the service timer has reached the programmed time interval. If the service timer exceeds the programmed time interval, alarm LED (3) will light up.

- Stop the unit, switch off the voltage and carry out the required service actions (see section *Preventive Maintenance*). Before proceeding with service, activate Service mode (see section *Service mode*).

WARNING



The longer interval service actions must also include the shorter interval actions. In the example above, carry out all service operations belonging to the 8000 running hours interval as well as those belonging to the 4000 running hours interval. The setting of the service

timer can be changed in function of the operating conditions. See section *Preventive maintenance schedule*.

- After servicing, reset the service timer. See section *Calling up/resetting the service timer*.

3.8 Remote control

The unit can be commanded via external switches, this function is always activated. The unit can be commanded to start/stop via digital inputs.



NOTE

Have the modifications checked by your supplier. Stop the unit and switch off the voltage before connecting external equipment. Only potential-free contacts are allowed.

WARNING



Persons switching on remotely controlled machines shall take adequate precautions to ensure that there is no one checking or working on the machine. To this end, a suitable notice shall be affixed to the remote start equipment.

3.9 Scrolling through screens

The scroll buttons (6-8) can be used to scroll through all screens. For most screens, the unit of measurement and the related pictograph are shown together with the screen number.

Example:

The screen shows the screen number (**P.SEt**), the unit used (**bar**) and the related pictograph for pressure unit.

Press the enter key (9) to call up the actual running hours.

Controller screens	Designation	Function
Main screen	Main with element outlet temperature	
Main screen	Main with rpm speed read from frequency converter	See section <i>Calling up/modifying main screen</i>
P.SEt	Pressure settings	See section <i>Calling up/modifying pressure band settings</i>
HoUr	Running hours	See section <i>Calling-up running hours</i>
SoFt	Software release version	See section <i>Calling Software release</i>
PAIr	Bluetooth pairing	See section <i>Calling-up Bluetooth pairing/ Discovery mode</i>

3.10 Calling up main screen

Starting from the Main screen:

- Press the scroll buttons (6-8) until the speed screen is shown.

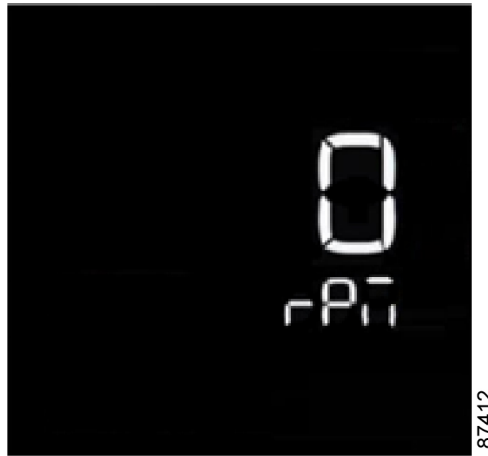

Figure 26: Speed screen

- Press the enter button (9) to see converter fault code 1.



Figure 27: Er1 screen

- Press the scroll buttons (6-8) to see converter fault code 2.



Figure 28: Er2 screen

3.11 Calling up/modifying pressure band settings

Set point pressure

Starting from the Main screen:

- Press the scroll buttons (6-8) until **P.SET** is shown.



Figure 29: Pressure setting screen

- Press the enter button (9) to modify.



Figure 30: Set point pressure changing

- Press the enter button (9) again to modify. The set point value starts blinking.
- Press the scroll buttons (6-8) to modify the set point pressure and press the enter button (9) to confirm.

Indirect stop level pressure

Starting from the Main screen:

- Press the scroll buttons (6-8) until **Indo** is shown.



Figure 31: Indirect stop level setting screen

- Press the enter button (9) to modify.



Figure 32: Indirect stop level pressure changing

- Press the enter button (9) again to modify. The indirect stop level value starts blinking.
- Press the scroll buttons (6-8) to modify the indirect stop level pressure and press the enter button (9) to confirm.

Direct stop level pressure

Starting from the Main screen:

- Press the scroll buttons (6-8) until **dlro** is shown.



Figure 33: Direct stop level setting screen

- Press the enter button (9) to modify.



Figure 34: Direct stop level pressure changing

- Press the enter button (9) again to modify. The direct stop level value starts blinking.
- Press the scroll buttons (6-8) to modify the direct stop level pressure and press the enter button (9) to confirm.

3.12 Calling up running hours

Starting from the Main screen:

- Press Scroll button (6-8) until **HoUr** is shown on the display.



Figure 35: Running hours screen

- Press Enter button (9).



Figure 36: Running hours value

The screen shows the unit used (x1000 hrs) and the value (11.25): the running hours of the unit are 11250 hours.

3.13 Calling up Software release

Starting from the Main screen:

- Press Scroll button (6-8) until **SoFt** is shown on the display.



Figure 37: Software release screen

- Press Enter button (9) to show the software release version.

3.14 Calling up Bluetooth pairing/ discovery mode

For Bluetooth connectivity a pairing with the device is necessary, see section *Connectivity*. This function is also a way to select the pair to the correct unit when multiple units are in the proximity. During the Bluetooth pairing, the controller generates and stores a random code.

This code is displayed on the controller screen and the app user must enter this code in the AirLink app.

The user enters this code to connect for the first time, after this the application allow automatic Bluetooth connection when the unit is in the range.

A short video instruction will guide you through the Smartphone App while proceeding with pairing.

Starting from the Main screen:

- Press Scroll button (6-8) until **PAIr** is shown on the display.



Figure 38: Bluetooth pairing screen/ discovery mode

- Press Enter button (9) to show Bluetooth PIN code. Attention, PIN code is composed by 6 sliding numbers.
- To exit from pairing, press Enter button (9) again.

3.15 Advanced menu

To enter inside the advanced menu Press buttons (6) and (8) together.

Advanced menu consists by following functions:

Controller screens	Designation	Function
SEru	Service mode	See section <i>Calling-up Service mode</i>
tEst	Screen Test	See section <i>Calling-up Screen Test</i>
FACT	Factory reset	See section <i>Calling-up Factory reset</i>

3.16 Service mode

Service mode can be only enabled/disabled physically on the controller, this function will allow to notify "in real time" the customer on the App that the service has been started on the machine and when it will be finished. It will also prevent remote start/stop when a service technician is working on a machine.

Once Service mode is active, it will not be possible to use any of the remote control functionalities like:

- Remote control with digital input

- Start/stop from Smartphone App
- Timer Schedule
- Controller firmware over-the-air (OTA) updates

When service mode is active, the service icon (3) is blinking. The only available command during Service Mode is from start/stop button (7) to start the unit.

Starting from the Main screen:

- Press buttons (6) and (8) together to enter inside advanced menu
- **SEru** is shown on the display.
- Press enter button (9) to change status.
- Use scroll button (6-8) to set “on” or “off”.
- Use enter button (9) to confirm the status.

3.17 Screen test

Starting from the Main screen:

- Press buttons (6) and (8) together to enter inside advanced menu.
- Press Scroll button (6-8) until **tEst** is shown on the display.
- Use enter button (9) to confirm the screen test.

The display now shows all icons that can be displayed:



Figure 39: Test screen

3.18 Calling up factory reset

This function restores the controller to original machine settings for pressure settings/units/starting. This parameter can only be modified after entering a password. Consult your supplier to use this function.

Starting from the Main screen:

- Press buttons (6) and (8) together to enter inside advanced menu
- Press Scroll button (6-8) until **FACT** is shown on the display.
- Press Scroll button (6-8) to enter a password.

3.19 Connectivity-Smartphone App

The controller has been designed as a standalone Internet of Things (IoT) solution. As such it includes integrated connectivity, which allows you to monitor and control your unit by using just your smartphone.

To enable this you just need the SMARTLINK application and an internet connection for your unit.

Download the SMARTLINK application from the Play Store and App Store to get the full functionality of the unit.

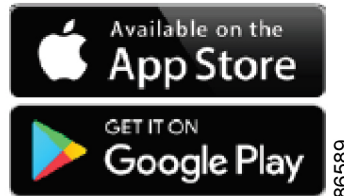

In order to have an overview of all the features available in the App we refer to the APP guidelines document which can be found in the media section of the App.

Unit configuration and control are made possible by Bluetooth communication with digital signature. To connect the unit to the cloud for monitoring purposes, a Wi-Fi connection or alternatively an Ethernet network with access to Internet is required.

The network settings can also be changed after the Wizard, the change is only available with a Bluetooth connection. Wi-Fi 802.11 b/g/n 2.4Ghz connection supported. For the Ethernet, use a UTP cable (CAT 5e) to connect the controller, the position of RJ45 connector is in the bottom side of the controller inside the electrical cubicle.

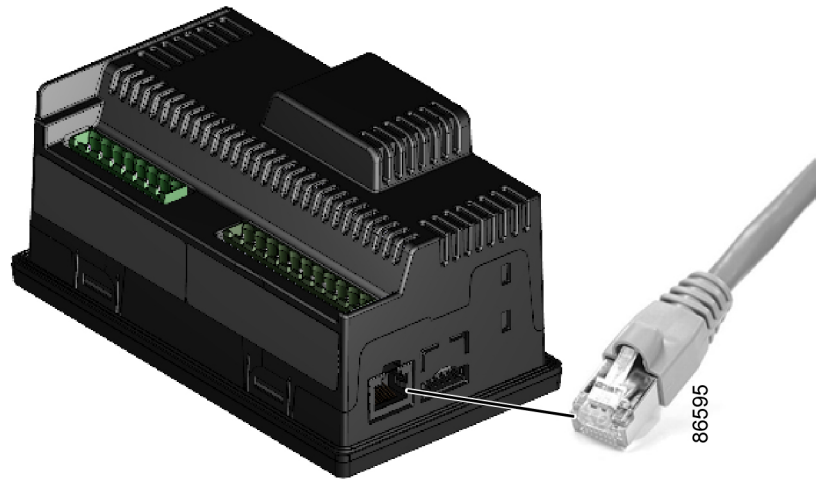

NOTE

Have the modifications checked by your supplier. Stop the unit and switch off the voltage before connecting external equipment. Only potential-free contacts are allowed.

In the App you will be able to change the settings of **“Wi-Fi”** or **“Ethernet”**, see App guidelines document.

When the unit is connected to the Wi-Fi network, the following icon



lights up on the controller. Otherwise for Ethernet, when the cable is plugged the following icon



lights up. If the internet is active and the unit is connected to the cloud, then the following icon



is on.

Machine events and notification

The smartphone application sends real time push notifications in case of alarms or shutdown. This allows you to always be up to date on the status of the machine. In case you want more information, you can always press on the pop-up message in your Smartphone and you will be redirected to the App.

Please look at the App guidelines document for a detailed explanation of this feature

OTA firmware update

Over-the-air (OTA) firmware updates are remote updates that do not require a direct connection to the unit. These are only possible if the controller of the machine is connected to the internet, so make sure to connect your machine to be able to use this feature. The benefits of this feature are to keep a product updated with the latest software to ensure optimal functionality, add the ability to receive new firmware to support additional features. Reduces time response to errors, bugs and security update without the need to physically service the unit.

When a firmware update is available, the following icon



appears on the unit's screen and a message is shown in your App

- Before starting the update, press the emergency stop button on the controller.
- Open your App to start the update procedure.
- Follow the instructions in the application.
- At the start of the update the following icon on the controller screen starts blinking



WARNING



Do not turn off the power of the unit during the firmware update or interrupt this procedure. During the update the machine will be stopped; THE SCREEN AND LEDS WILL BE OFF.

- The firmware update loads the new firmware on your Compressor. This process can take a few minutes. Once the firmware update is complete, the controller will reboot.
- Reset the emergency stop alarm and manual start is required after the update.

Pressure settings

Changing pressure settings is one of the useful features only available in the App, when the smartphone is connected via Bluetooth to the unit.

Please look at the App guidelines document for a detailed explanation of this feature.



WARNING

If the unit is in standby and the loading pressure is set above the current pressure shown on the controller, the unit will start.

Timer schedule

With a timer schedule, you will not need to go every day to your unit to start and stop it. You will just need to specify a start and stop hour in the App. To activate the function and set the timers, you will need Bluetooth pairing with the unit and an internet connection. This is needed to send the information from the phone to the controller. Then the information will be stored in the controller itself.

Please look at the App guidelines document for a detailed explanation of this feature.

When the Timer schedule is active, the related pictograph



will be shown on the controller display.



Figure 40: Main screen with timer schedule active

4 Installation

4.1 Installation proposal

Outdoor/altitude operation

If the compressor is installed outdoors or if the ambient temperature can be below 0 °C (32 °F), precautions must be taken. In this case, and also if operating at high altitude, consult your supplier.

Moving/lifting

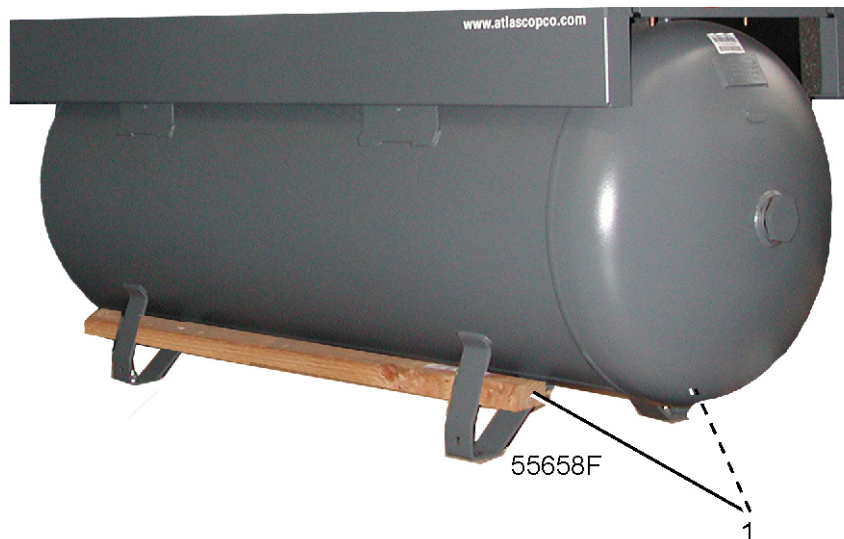

Figure 41: Transport by a pallet truck

WARNING



To prevent a tank-mounted model from falling over during transport by a pallet truck: push the forks underneath the air receiver and place a wooden beam (1) (cross-section approx. 4 x 6 cm / 1.6 x 2.4 in) through the supports on both sides of the receiver. While holding the compressor, slowly lift the forks until the receiver is secured between the beams.

Installation proposal

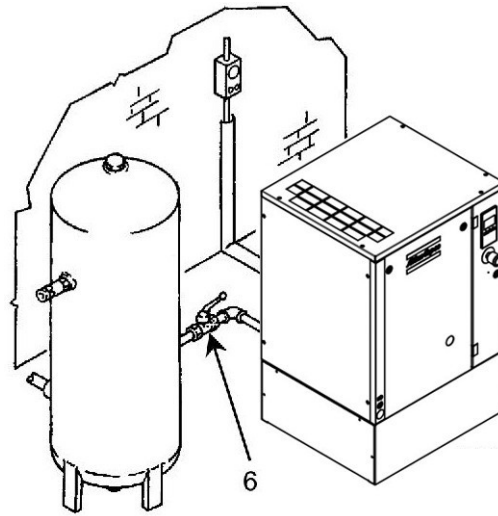

86128D

Figure 42: Installation proposal, floor-mounted

Reference	Description
6	Outlet valve

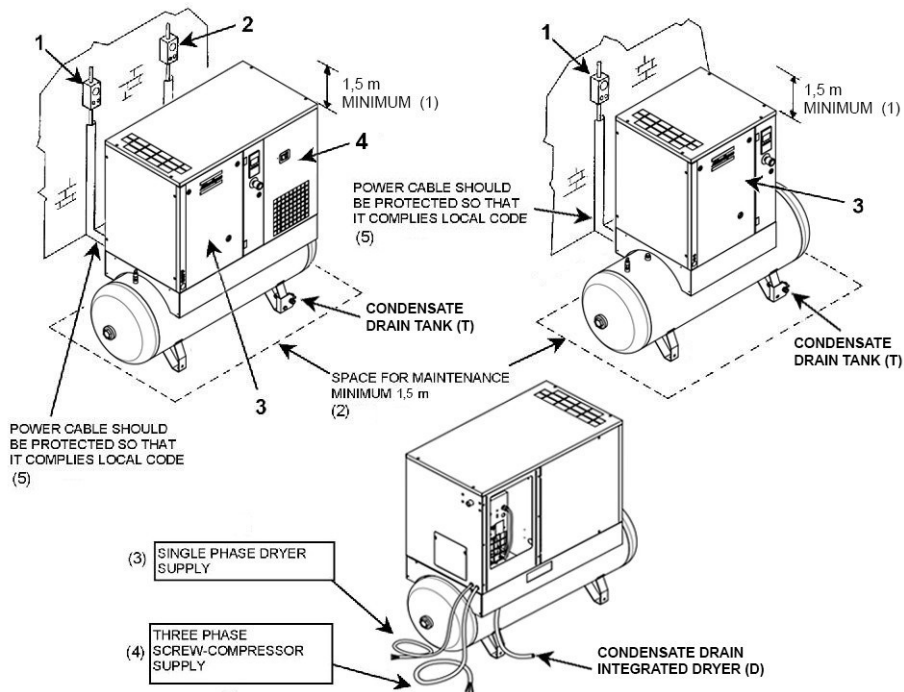

86129D

Figure 43: Installation proposal, tank-mounted

Reference	Description
1	Isolating switch and fuses, compressor
2	Isolating switch and fuses, dryer

Reference	Description
3	Front panel, compressor
4	Dryer
(1)	Minimum 1.5 m (59 in)
(2)	Space for maintenance, minimum 1.5 m (59 in)
(3)	Single-phase dryer supply
(4)	Three-phase screw compressor supply
(5)	The power cable should be protected so that it complies with local regulations
D	Condensate drain integrated dryer
T	Condensate drain tank

1. Install the compressor on a solid, level floor suitable for taking the weight.

The recommended minimum distance between the top of the unit and the ceiling is 1.5 m (58.5 in).

The minimum distance between the wall and the back of the compressor must be 300 mm (19.5 in).

Floor-mounted versions must be installed with a suitable air receiver with a minimum capacity of 200 l (60 US gal), if the compressor is not equipped with an unloader valve (i.e. G2-4).

The air receiver should not be bolted to the floor.



DANGER

The pipes between a floor-mounted compressor and the air receiver are hot.

2. Close the outlet valve of the compressed air.

Connect the air net to the valve.

3. Calculate the pressure drop over the air delivery pipe as follows:

$$\Delta p = (L \times 450 \times Q_c^{1.85}) / (d^5 \times P), \text{ with}$$

d = Inner diameter of the pipe in mm

Δp = Pressure drop in bar (recommended maximum: 0.1 bar (1.5 psi))

L = Length of the pipe in m

P = Absolute pressure at the compressor outlet in bar

Q_c = Free air delivery of the compressor in l/s

4. Install the inlet grids and ventilation fan in such a way that any recirculation of cooling air to the compressor or dryer is avoided.

The air velocity to the grids must be limited to 5 m/s (200 in/s).

The required ventilation capacity to limit the temperature of the compressor room can be calculated from the following formula:

$$Q_v = 0.92 N / \Delta T$$

Q_v = Required ventilation capacity in m³/s

N = Shaft input of compressor in kW

ΔT = Temperature increase in the compressor room in °C

5. Direct the condensate drain pipe from the automatic drain of the dryer (D) towards a drain collector and do the same for the pipe from the manual drain valve underneath the tank (T). The drain pipes to the drain collector must not dip into the water of the drain collector. See section *Starting* for the location of the components.

4.2 Dimension drawings

The dimension drawing can be found in the technical documentation supplied with the unit.

Drawing number	Model description
9828 0850 44	Pack, floor-mounted
9828 0850 46	Pack, tank-mounted
9828 0850 45	Full-Feature, floor-mounted
9828 0850 47	Full-Feature, tank-mounted

Text on drawings	Translation or explanation
Emergency stop switch	Emergency stop switch button (only compressor)
Main power supply	Compressor power supply (supply cable)
Cooling air and compressor inlet	Cooling air and compressor inlet
Cooling air outlet of compressor and motor	Cooling air outlet of compressor and motor
Air inlet filter	Air inlet filter (only floor-mounted)
Service panel	Compressor service panel
External box	External box on back panel (depends on model)
Extra venting	Extra openings for venting on back panel (depends on model)
Compressor controller	Compressor controller
Oil level indicator	Oil level indicator
Compressed air outlet	Compressed air outlet
Air delivery	Compressed air outlet delivery line
Forklift openings	Forklift openings (only floor-mounted, Full-Feature)
Valve (supplied loose)	Valve air outlet (only air receiver)
Center of gravity	Center of gravity
Cubicle door fully open	Cubicle door fully open
Air receiver manual drain	Air receiver manual drain
Condensate drain dryer	Condensate drain from integrated dryer
Dryer inlet cooling air	Dryer inlet cooling air
Dryer outlet cooling air	Dryer outlet cooling air
Dryer switch	Dryer switch ON/OFF
Dryer service panel	Dryer service panel for maintenance
Dryer power supply	Dryer power supply (supply cable)

4.3 Electrical connections



DANGER

Always disconnect the power supply before working on the electrical circuit!

General instructions

1. Install an isolating (disconnector) switch near the compressor.

2. Install fuse, see section *Sizes of fuses*.
3. Check transformers for correct connection, if fitted.
4. For selection of power supply line cable, see section *Electric cable size*.

Connect the power supply cables to terminals L1, L2 and L3 and the neutral conductor (if applicable) to terminal (N). Connect the earth conductor to terminal PE/GND.

4.4 Pictographs

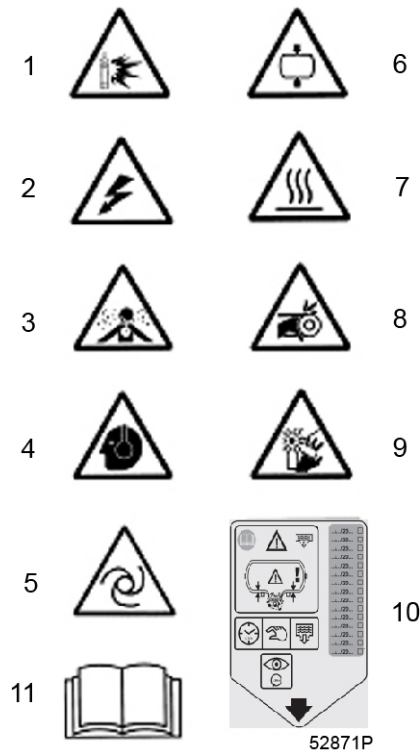

Reference	Description
1	Warning: possible air/fluid discharge
2	Warning: voltage
3	Warning: air must not be inhaled
4	Warning: wear ear protectors
5	Warning: machine may start automatically
6	Warning: pressure
7	Warning: hot parts
8	Warning: moving parts
9	Warning: rotating fan
10	Drain the condensate daily and inspect the vessel yearly. Write down the inspection dates.
11	Read the instruction manual

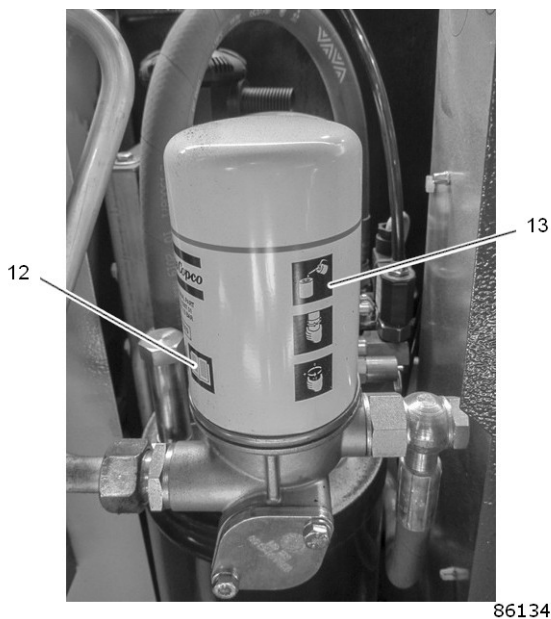

86134D

Reference	Description
12	Read the instruction manual before carrying out any maintenance or repair work.
13	Lightly oil the gasket of the oil filter, screw the filter on and tighten by hand.

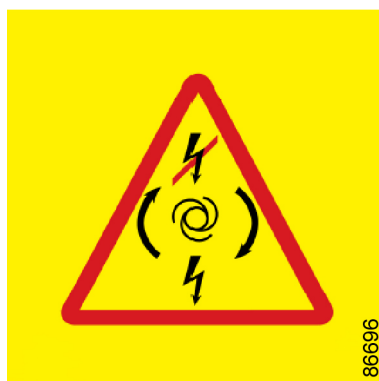

Figure 44: ARAVF label

Reference	Description
ARAVF	Automatic restart after voltage failure

5 Operating instructions

5.1 Initial start-up

Safety



WARNING

The operator must apply all relevant safety precautions.

General preparation

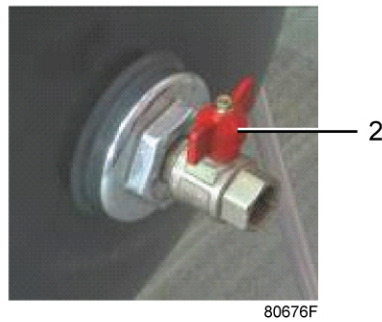

Figure 45: Air outlet valve on air receiver



Figure 46: Condensate drain valve on air receiver



Figure 47: Automatic condensate drain

1. Consult the installation instructions (see section *Installation proposal*).
2. Check that the electrical connections correspond to the local codes. The installation must be earthed and protected against short circuits by fuses in all phases. An isolating switch must be installed near the compressor.
3. Fit the outlet valve (2), close it and connect the air net to the valve.

Connect the condensate drain valve (4) of the air receiver and, in case of a Full-Feature version, the automatic drain outlet (Da) to a drain collector. Close the valve.

Oil system



NOTE

If more than 3 months have passed between assembly and installation, make sure to lubricate the compressor before starting up.

1. Remove the front panel.
2. Unscrew the fixing bolts on the top and remove the panel.
3. Unscrew the cover of the air filter (AF) and remove the filter element.
4. Open the valve (7) and drain approximately 0.2 l (0.05 US gal/0.04 Imp gal) of oil into a clean receptacle. Carefully pour this oil through the filter housing into the compressor element.
5. Fit the air filter and screw on the filter cover.
6. Refit the top and front panels.

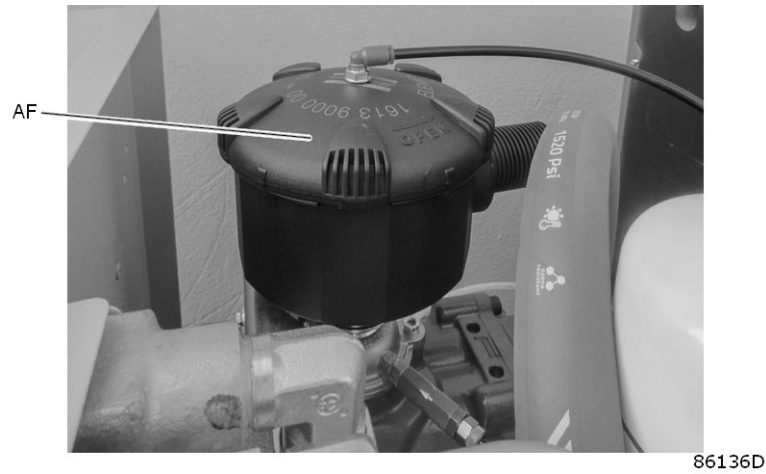

Figure 48: Air filter

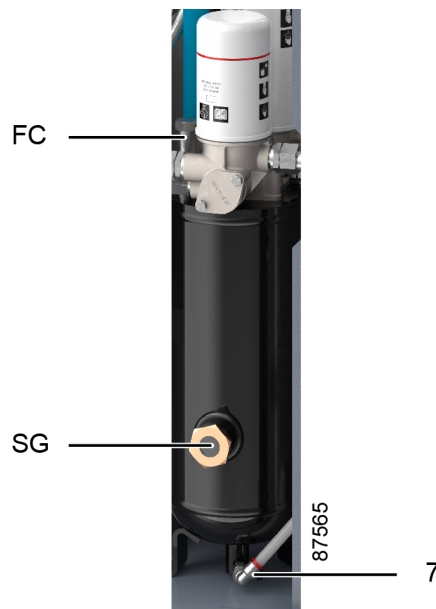
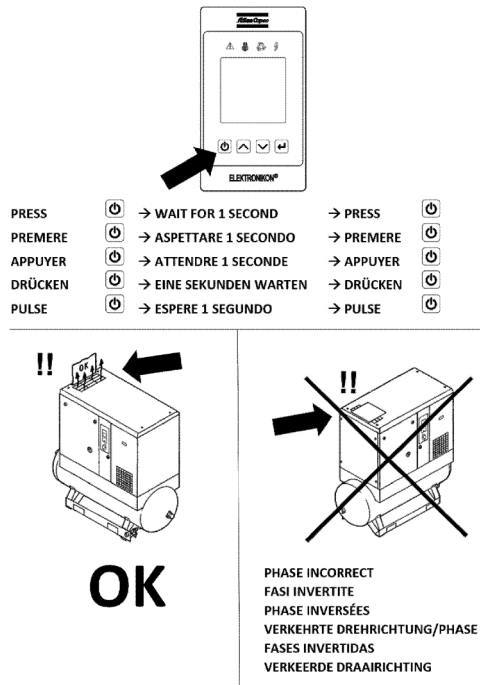

Figure 49: Oil level sight-glass

1. Check the oil level.
2. Stop the unit and wait for the foam to disappear (normally about 3 minutes). The oil level should be visible on the sight glass (SG). Never measure the oil level on a unit that has been stopped for more than 10 minutes. Do not overfill. Always use the same type of oil.

Start-up



87262

Figure 50: Start-up sheet

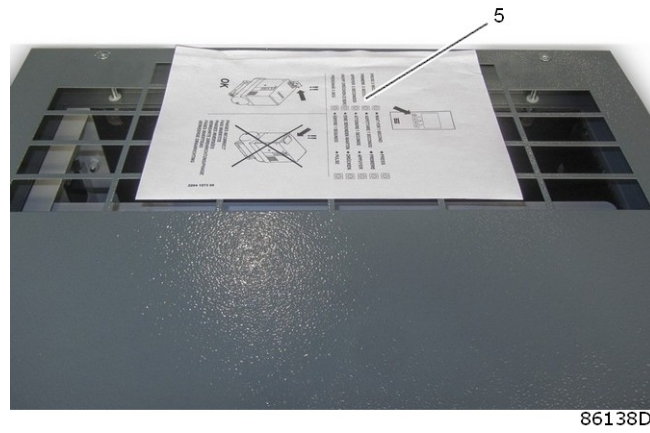

86138D

Figure 51: Label on the top

WARNING



All electrical work should be carried out by professionally qualified people.

1. Check that all bodywork panels are fitted.
2. Check that the sheet (5) explaining the procedure for checking the motor rotation direction is affixed to the cooling air outlet of the compressor (grating on the compressor top). Consult section *Dimension drawings*.
3. Switch on the voltage. Press the start button and after 1 second press the stop button.

4. Check the rotation direction of the motor. If the motor rotation direction is correct, the sheet on the top grating will be blown upwards. If the sheet remains in place, the rotation direction is incorrect. If the rotation direction is incorrect, switch off the voltage, open the isolating (disconnecter) switch (IG) and contact your supplier.
5. Start and run the compressor for a few minutes. Check that the compressor is operating normally.

5.2 Starting

Starting the compressor

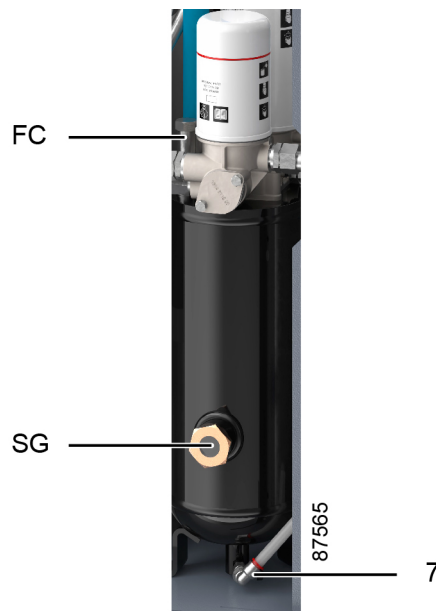

Figure 52: Position of oil sight glass and filler plug

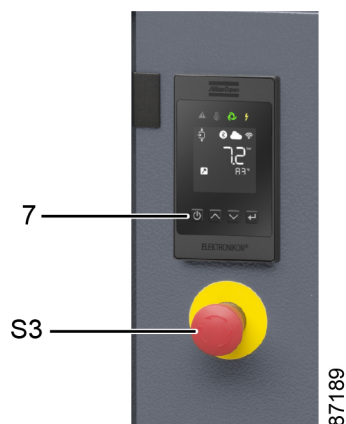

Figure 53: Control panel

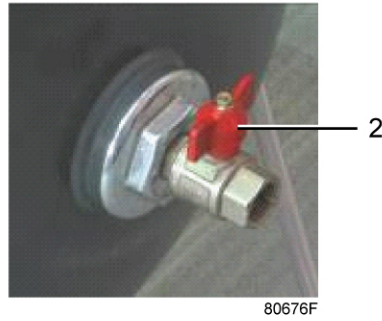

Figure 54: Air outlet valve on air receiver



Figure 55: Condensate drain valve on air receiver

1. Before starting, check the oil level in accordance with step 5 of these steps.
2. Switch on the voltage.
3. Open the air outlet valve (2).
4. Push the start button (7).

WARNING



The maximum number of starts is limited at 10 per hour. It is strongly recommended to operate the compressor with a load factor of more than 10% to avoid condensate in the oil.

5. Regularly check the oil level. 10 to 15 minutes after stopping, the sight glass (SG) should be between 1/4 and 3/4 full.

If the oil level is too low, stop the compressor, depressurize the oil system by unscrewing the oil filler plug (FC) one turn and wait a few minutes. Remove the plug and top up the oil until the sight glass is 3/4 full. Do not overfill. Fit and tighten the plug (FC).

In automatic operation, the regulator is automatically controlling the compressor, i.e. loading, unloading, stopping of the motors and restarting.

6. Regularly check the working pressure and the dew point (Full-Feature units).
7. Regularly check that condensate is drained (Da) during operation.

Starting the dryer

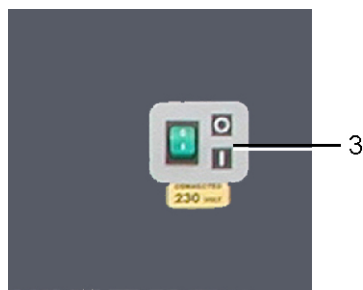

52885F

Figure 56: Dryer on/off switch

1. Switch on the voltage to the dryer and start it by moving the switch (3) to position I.

WARNING



Switch on the dryer before starting the compressor. The dryer must remain switched on when the compressor is operating to ensure that the air piping remains condensate-free.

WARNING



If the dryer is switched off, wait at least 5 seconds before restarting the dryer. This allows balancing the internal pressure of the dryer.

5.3 Stopping

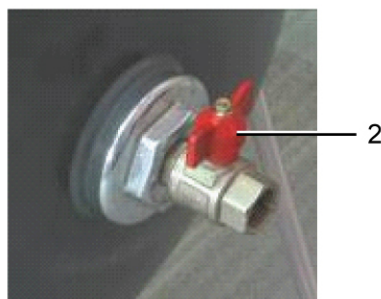

80676F

Figure 57: Air outlet valve

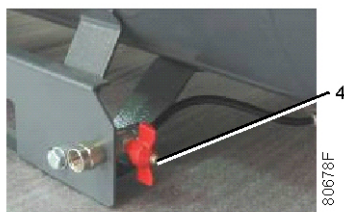

80678F

Figure 58: Condensate drain valve on air receiver

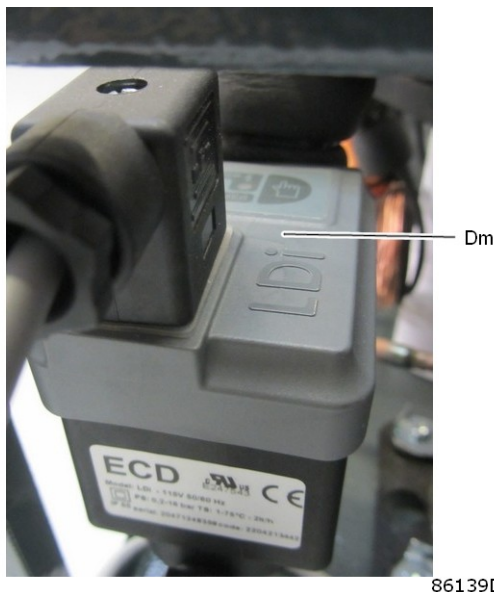

Figure 59: Dryer manual drain

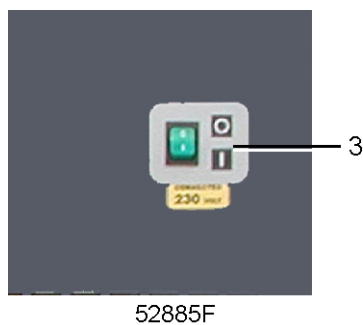

Figure 60: Dryer on/off switch



Figure 61: Control panel

1. On Full-Feature units: move the switch (3) of the dryer to position 0.
Push the start/stop button (7) on the controller. The compressor will unload. When the unload time has elapsed, the compressor is stopped and the controller goes back to the main screen.

To stop the compressor immediately in the event of an emergency, press the emergency stop button (S3), see section *Control panel*. After remedying the fault, unlock the button by rotating it.

**NOTE**

Only use the emergency stop button in the event of an emergency. Avoid using the button for normal stopping of the compressor.

2. Close the air outlet valve (2) and switch off the voltage to the compressor.
3. Push the condensate manual drain (Dm) for a few seconds to release any condensate from the dryer.
4. Open the condensate drain valve (4) of the air receiver for a few seconds to drain any condensate and then close the valve.

**DANGER**

The air dryer and air receiver remain under pressure.

**DANGER**

The integrated filter (if installed) remains pressurized.

**DANGER**

If maintenance or repair work is necessary, consult section *Problem solving* for all relevant safety precautions.

5.4 Taking out of operation

Location of parts

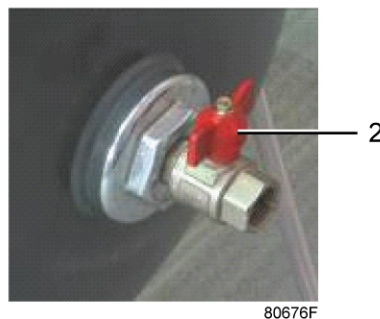

Figure 62: Air outlet valve

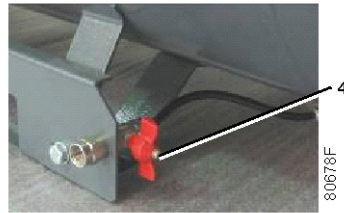

Figure 63: Condensate drain valve on air receiver

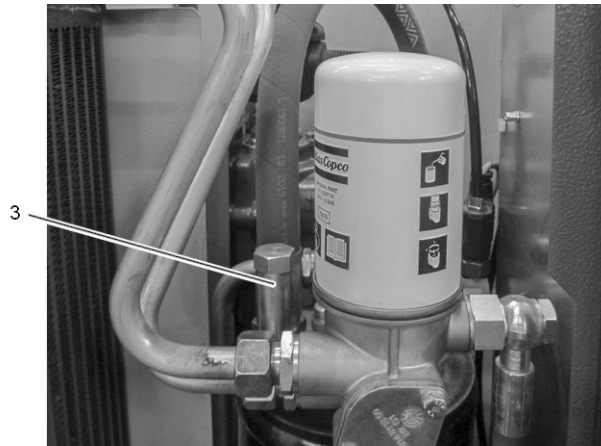

Figure 64: Oil filler plug

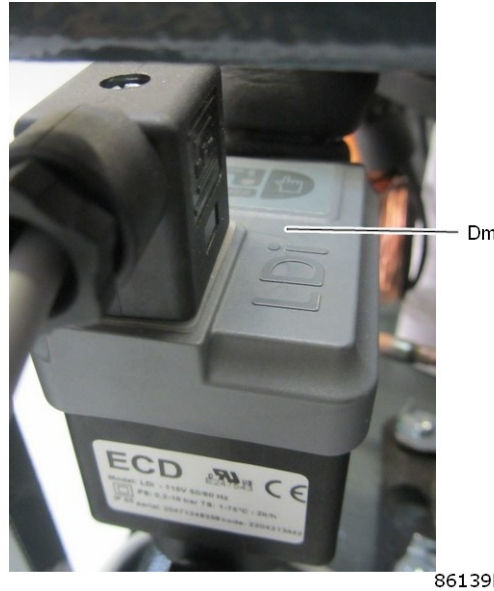

Figure 65: Dryer manual drain

Procedure

This procedure should be carried out at the end of the compressor's service life.

1. On Full-Feature units: move the switch (3) of the dryer to position 0.

Stop the compressor and close the air outlet valve (2).

2. Switch off the voltage and disconnect the compressor from the mains.
3. Depressurize the compressor by opening plug (3) one turn.

Push the condensate manual drain (Dm) for a few seconds to release any condensate from the dryer.

Open the condensate drain valve (4) of the air receiver.

4. Shut off and depressurize the part of the air net which is connected to the outlet valve. Disconnect the compressor from the air net.
5. Drain the oil and condensate circuits.
6. Disconnect the compressor condensate outlet and valve from the condensate net.

6 Maintenance

6.1 Preventive maintenance schedule

Warning

WARNING

Before carrying out any maintenance, repair work or adjustments, proceed as follows:



- Stop the compressor.
- Close the air outlet valve.
- Open the condensate drain valve to depressurize the air system between air receiver and outlet valve.
- Press the emergency stop button.
- Switch off the voltage. Lock Out and Tag Out (LOTO).
- Wait 5 minutes for the vessel to depressurize.
- Wait 10 minutes for the converter capacitors to discharge before starting any electrical checks, work and/or repair.

For detailed instructions, see the next sections.

The operator must apply all relevant *Safety precautions during maintenance or repair.*

Warranty-Product Liability

Use only authorized parts. Any damage or malfunction caused by the use of unauthorized parts is not covered by Warranty or Product Liability.

General

When servicing, replace all removed gaskets, O-rings and washers.

Intervals

Carry out maintenance at the interval which comes first. The local Atlas Copco Customer Center may overrule the maintenance schedule, especially the service intervals, depending on the environmental and working conditions of the compressor.

The "longer interval" checks must also include the "shorter interval" checks.

Preventive maintenance schedule

Period (1)	Running hours (1)	Action
Daily	--	Check the oil level. After stopping, drain the condensate from the air receiver by means of the manual drain valve (4), see section <i>Stopping</i> .
--	50	Check belt tension. Adjust if necessary.
Weekly	50	Drain condensate from the oil separator vessel.

Period (1)	Running hours (1)	Action
		Check the filtering panels of the cubicle door and air inlet. Clean if necessary.
3-monthly	--	For compressors with PDX filter: check the service indicator; replace the filter if necessary.
	500 (2)	Inspect the air filter and the electrical cabinet filter. Clean if necessary.
	1000	Check the tension and the condition of the belts. Adjust if necessary.
	1000 (2)	Inspect the oil cooler; clean if necessary.
"	1000 (2)	For Full-Feature versions: inspect the condenser of the dryer; clean if necessary.
Yearly	4000	Replace the oil filter.
		Clean the condenser of the dryer and apply the drain wear kit.
		Clean the finned surface of the air-oil cooler.
		Change the filter panel.
		For compressors with an inline filter, replace the filter.
	--	Check and, if needed, replace the belts.
		Safety valves: follow the applicable national legislation.
		Have the operation of sensors, electrical interlockings and components checked.
		Retighten all the power cable connections.
		Inspect the air receiver. The air receiver must no longer be used and must be replaced if the wall thickness is less than the minimum value, specified in the technical documentation of the air receiver.
	4000 (2)	Replace the air filter.
	4000 (3)	If Roto-Inject Fluid Ndurance is used, change the oil.
2-yearly	4000 (2)	Replace the oil separator.
	8000	Service the instrument block: thermostatic and MPV kit.
		Check and clean the inlet valve. Use the unloader kit.
		Replace the belts.
		Check the status of the oil return valve and oil pipes.
	Replace the non-return valve of the scavenge line.	
8000 (3)	If Roto Synthetic Fluid Xtend Duty is used, change the oil.	

(1): whichever comes first

(2): more frequently in a dusty environment

(3): The indicated oil exchange intervals are valid for standard operating conditions (see section *Reference conditions and limitations*) and nominal operating pressure (see section *Compressor data*). Exposure of the compressor to external pollutants or operation at high humidity combined with low duty cycles may require a shorter oil exchange interval. Contact your supplier if in doubt.

Important



DANGER

Always consult your supplier if a timer setting has to be changed.



DANGER

For the change interval of oil and oil filter in extreme conditions of temperature, humidity or cooling air, consult your supplier.



DANGER

Any leakage should be attended to immediately. Damaged hoses or flexible joints must be replaced.

6.2 Drive motor

General

Keep the outside of the electric motor clean for efficient cooling. If necessary, remove dust with a brush and/or compressed air jet.

Description

The motor bearings are greased for life.

6.3 Oil specifications



WARNING

Avoid mixing lubricants of different brands or types as they may not be compatible and the oil mix may have inferior properties. A label, indicating the type of oil filled ex factory, is stuck on the air receiver/oil tank.

It is strongly advised to use the recommended lubricants. See section *Preventive maintenance schedule* for the recommended oil change intervals.

For part numbers, consult the Spare Parts List.

Roto-Inject Fluid NDURANCE

Exchange interval for Roto-Inject Fluid Ndurance

Ambient temperature	Element outlet temperature	Exchange interval *	Maximum time interval *
up to 30 °C (86 °F)	up to 95 °C (203 °F)	4000	1 year
from 30 °C (86 °F) up to 35 °C (95 °F) (see note)	from 95 °C (203 °F) up to 100 °C (212 °F)	3000	1 year
from 35 °C (95 °F) up to 40 °C (104 °F) (see note)	from 100 °C (212 °F) up to 105 °C (221 °F)	2000	1 year
above 40 °C (104 °F)	above 105 °C (221 °F)	use Roto Synthetic Fluid XTEND DUTY	

Note: the presence of dust and/or high humidity may require a shorter exchange interval. Consult Atlas Copco.

Atlas Copco's Roto-Inject Fluid Ndurance is a premium mineral oil-based lubricant for 4000 running hours, specifically developed for use in single-stage oil-injected screw compressors running in mild conditions. Its specific formulation keeps the compressor in excellent condition. Roto-Inject Fluid Ndurance can be used for compressors operating at ambient temperatures between 0 °C (32 °F) and 40 °C (104 °F). If the compressor is regularly operating in ambient temperatures between 40 °C and 46 °C (115 °F), it is recommended to use Roto Synthetic Fluid ULTRA or Roto Synthetic Fluid XTEND DUTY.

Roto Synthetic Fluid XTEND DUTY

Exchange interval for Roto Synthetic Xtend Duty

Ambient temperature	Element outlet temperature	Exchange interval *	Maximum time interval *
up to 35 °C (95 °F)	up to 100 °C (212 °F)	8000	2 years
from 35 °C (95 °F) up to 40 °C (104 °F) (see note)	from 100 °C (212 °F) up to 105 °C (221 °F)	6000	2 years
above 40 °C (104 °F)	above 105 °C (221 °F)	5000	2 years

Note: the presence of dust and/or high humidity may require a shorter exchange interval. Consult Atlas Copco.

Atlas Copco's Roto Synthetic Fluid XTEND DUTY is a high-quality synthetic lubricant for 8000 running hours for oil-injected screw compressors which keeps the compressor in excellent condition. Because of its excellent oxidation stability, Roto Synthetic Fluid XTEND DUTY can be used for compressors operating at ambient temperatures between 0 °C (32 °F) and 46 °C (115 °F). Roto Synthetic Fluid XTEND DUTY is the standard lubricant for oil-injected screw compressors equipped with freeze protection or Energy Recovery.

Roto Synthetic Foodgrade Ultra

Special oil, delivered as an option.

Atlas Copco's Roto Synthetic Foodgrade Ultra is a unique high-quality synthetic lubricant, specifically created for oil-injected screw compressors that provide air for the food industry. This lubricant keeps the compressor in excellent condition. Roto Synthetic Foodgrade Ultra can be used for compressors operating at ambient temperatures between 0 °C (32 °F) and 46 °C (115 °F).

Roto Synthetic Foodgrade Ultra has all the required certification for use in the food & beverage industry: like NSFH1, Kosher, Halal and Allergen Free approvals.

If the compressor is regularly operating in ambient temperatures above 35 °C (95 °F), the oil lifetime is reduced. See section *Preventive maintenance schedule*.

6.4 Oil, filter and separator change

Important

NOTE

Never mix oils of different brands or types. A label, indicating the type of oil filled ex factory, is stuck on the air receiver/oil tank.



Always drain the compressor oil at all drain points. Used oil left in the compressor can shorten the lifetime of the new oil.

If the compressor is exposed to external pollutants, is being used at high temperatures (oil temperature above 90°C / 194°F) or is being used under severe conditions, it is advisable to change the oil more frequently. Consult your supplier.

Procedure

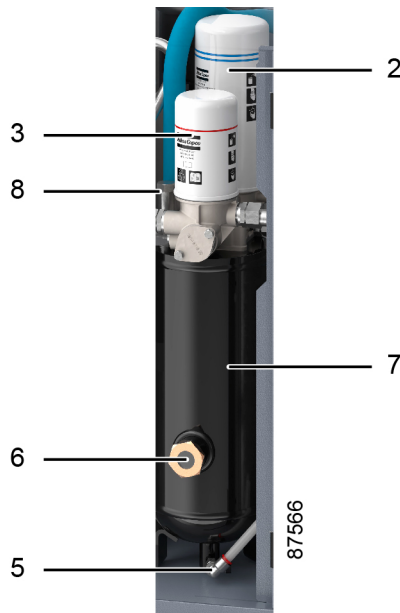

Figure 66: Location of oil filter and separator



Figure 67: Drain valve of air receiver

1. Run the compressor until warm. Stop the compressor, close the air outlet valve and switch off the voltage. See section *Stopping*.
2. Remove the front and top panels.
3. Depressurize the compressor by unscrewing the filler plug (8) one turn to permit any pressure in the system to escape.

Remove the plug after the system is depressurized.

4. Depressurize the air receiver by opening the drain valve (4).
5. Drain the oil by opening the drain valve (5). Close the valve after draining. Deliver the drained oil to the local oil collection service.
6. Remove the oil filter (3) and separator (2). Clean the seats on the manifold.
7. Oil the gaskets of the new filter and separator and screw them into place. Tighten firmly by hand.
8. Remove the filler plug (8) and fill the oil tank (7) with oil until the level reaches the top of sight-glass (6). Ensure no dirt gets into the system. Refit and tighten the filler plug (8).
9. Fit the bodywork panels.
10. Close the drain valve (4) of the air receiver.
11. Run the compressor for a few minutes.
12. Stop the compressor and wait a few minutes to allow the oil to settle and the foam to disappear.

13. If the oil level is too low, depressurize the system by unscrewing the filler plug (8) one turn to permit any pressure in the system to escape. Depressurize the air receiver by opening the drain valve (4).
14. Add oil as necessary. The sight-glass should be 3/4 full. Re-tighten the plug (8) and close the drain valve (4) of the air receiver.

6.5 Storage after installation

If the compressor is stored without running from time to time, consult your supplier as protective measures may be necessary.

6.6 Service kits

For overhauling and preventive maintenance, a wide range of service kits is available. Service kits comprise all parts required for servicing the component and offer the benefits of genuine Atlas Copco parts while keeping the maintenance budget low.

A full range of extensively tested lubricants, suitable for your specific needs, is also available to keep the compressor in excellent condition.

Consult the Spare Parts List for part numbers.

7 Adjustments and servicing procedures

7.1 Air filter

Replacing the air filter

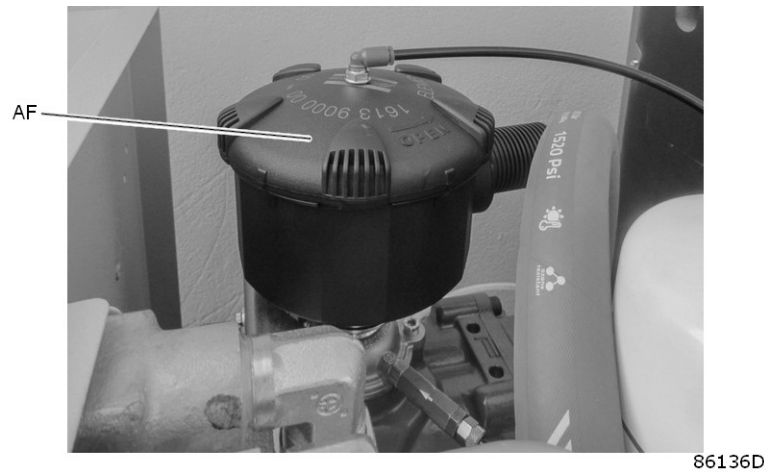

Figure 68: Air filter

1. Stop the compressor, close the air outlet valve and switch off the voltage.
2. Remove the front and top panel of the compressor housing.
3. Unscrew the filter cover (AF) and remove the filter element. Discard the air filter element.
4. Fit the new element and screw on the filter cover.
5. Refit the top and front panel.

7.2 Coolers

Cleaning the coolers

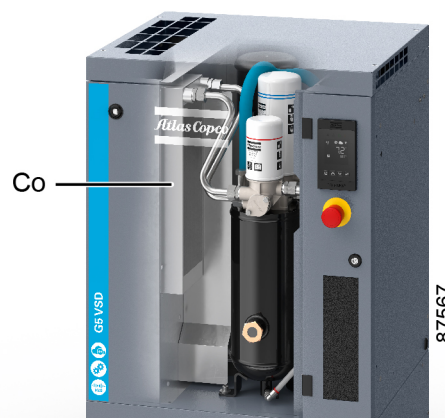

Figure 69: Oil cooler

1. Keep the oil cooler (Co) clean to maintain the cooling efficiency.

2. Stop the compressor, close the air outlet valve and switch off the voltage. Remove any dirt from the cooler with a fiber brush. Then clean using an air jet. Never use a wire brush or metal objects.

7.3 Drain valve

Location



Figure 70: Condensate drain valve on air receiver



86140D

Figure 71: Oil filler plug

Testing

1. Before removing the valve, stop the compressor (see section *Stopping*).
On a Full-Feature unit, also stop the dryer.
2. Close the air outlet valve and switch off the voltage.
3. Open the drain valves (4) (if applicable) and unscrew the filler plug (3) one turn to permit any pressure in the system to escape.

DANGER



If the valve does not open at the set pressure stamped on the valve, replace the valve. No adjustments are allowed. Never run the compressor without a safety valve.

7.4 Belt set exchange and tensioning

Location of parts

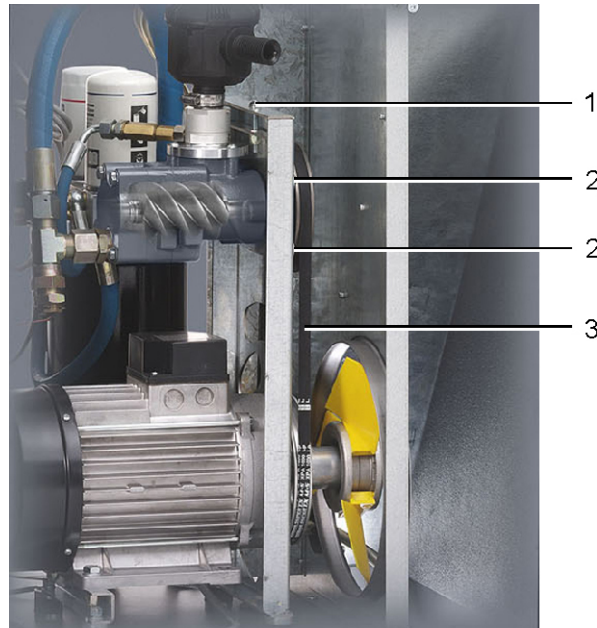

52880F



DANGER

Read the warning in section *Preventive maintenance*.

Belt tensioning procedure

1. Stop the compressor, close the air outlet valve and switch off the voltage.
For Full-Feature versions: also stop the dryer. (See section *Stopping*).
2. Remove the front panel of the compressor housing.
3. Remove the side, back and top panels of the compressor housing.
4. Loosen the 4 bolts (2) by one turn.
5. Adjust the belt tension by turning the tensioning nut (1).

Check belt tensioning with one of the following methods:

- Belt tension frequency meter Method

Turn the belts by hand. Push the belt inwards with a tool, for example a wrench, or with your fingers. Read the value on the instrument and compare it with the values written on the label attached to the element-motor frame. If the tension is not set correctly, adjust the belt tension and repeat the procedure.

- Forces Method

The tension is correct when a force of 50 N (11.25 lb-ft) applied at the midpoint of the belt causes a deflection of 6 mm (0.23 in).

6. Re-tighten the bolts (2).
7. Refit the bodywork panels.

Belt replacement procedure

1. Stop the compressor, close the air outlet valve and switch off the voltage.
For Full-Feature versions: also stop the dryer. (See section *Stopping*).
2. Remove the front panel of the compressor housing.
3. Remove the side, back and top panels of the compressor housing.
4. Loosen the 4 bolts (2) by one turn.
5. Release the belt tension by loosening the tensioning nut (1).
6. Remove the belt via the fan cowl opening. Install the new belt via the same opening.
7. Tension the belt (3) as described above.
8. Refit the bodywork panels.
9. Check the belt tension after 50 running hours.



DANGER

Tensioning of the belts must be performed with specific dedicated tooling.

8 Problem solving

For the location of the components, see sections:

- *Introduction*
- *Air dryer*
- *Operating instructions*

Attention

WARNING



Use only authorized parts. Any damage or malfunction caused by the use of unauthorized parts is not covered by Warranty or Product Liability.

Apply all relevant *Safety precautions during maintenance or repair.*

Before carrying out any maintenance or repair work on the compressor:

1. Push the stop button (7). Wait until the compressor has stopped and switch off the voltage. See section *Stopping*.
2. Open the isolating switch to prevent an accidental start.
3. Close the air outlet valve (2) and depressurize the compressor by opening the oil filler plug (3) one turn.
4. Open the manual condensate drain valves (4 and/or 5).

The air outlet valve (2) can be locked during maintenance or repair as follows:

1. Close the valve.
2. Remove the screw fixing the handle.
3. Remove the handle.
4. Fit the screw.

Faults and remedies

For all references given hereafter, see sections *Air flow diagram*, *Initial start-up*, *Regulating system*.

Condition	Fault	Remedy
The machine does not start	No power	Check power supply.
	Fuse blown	Replace fuse.
	The frequency converter alarm is triggered	Check the table in section <i>Shutdown</i> .
The machine does not start, high oil temperature lamp is on (temperature switch tripped)	Oil cooler is dirty	Clean cooler.
	Ambient temperature too high	Improve ventilation in compressor room.
	Oil level too low	Top up oil tank.
The compressor does not reach working pressure	Blow-off solenoid valve (Y1) remains open	Check; replace valve if necessary.
Excess oil consumption	Oil separator (OS) clogged	Replace oil separator.
	Oil level too high	Drain to correct level.

Table 1: Compressor

Condition	Fault	Remedy
No compressed air passes through the dryer	Pipes are frozen inside	Hot-gas by-pass valve malfunctioning; consult Atlas Copco.
Condensate in the piping	Insufficient condensate drain	Check the operation of timer (T).
	The dryer is working outside its rating	Check room temperature - air temperature at dryer. Clean the condenser and check operation of fan.
The compressor head is very hot (above 55 °C / 131 °F) - motor overload	The dryer is working outside its rating	Check room temperature - air temperature at dryer. Clean the condenser and check operation of fan.
	Insufficient refrigerant in dryer	Have system checked for leaks or refilled.
The motor hums and does not start	Line voltage too low	Check power supply.
	The machine was switched off and on again too rapidly (not enough time for the pressure equalization)	Wait a few minutes before starting the machine again.

Table 2: Air dryer

9 Technical data

9.1 Electric cable size

Attention

DANGER



Local regulations remain applicable if they are stricter than the values proposed below.

The voltage drop must not exceed 5 % of the nominal voltage. It may be necessary to use cables of a larger size than those stated to comply with this requirement.

Recommended cable size

Voltage (V)	Frequency (Hz)	Cable size				
		G 2 VSD	G 3 VSD	G 4 VSD	G 5 VSD	G 7 VSD
IEC						
400/3	50	1.5 mm ²	1.5 mm ²	1.5 mm ²	2.5 mm ²	4 mm ²

Table 3: Cable size, IEC

Voltage (V)	Frequency (Hz)	Cable size			
		G 2 VSD	G 4 VSD	G 5 VSD	G 7 VSD
UL/CSA					
460/3	60	AWG14	AWG14	AWG14	AWG12

Table 4: Cable size, UL/CSA

9.2 Sizes of fuses

Voltage (V)	Frequency (Hz)	Fuse size, Gg type				
		G 2 VSD	G 3 VSD	G 4 VSD	G 5 VSD	G 7 VSD
IEC						
400/3	50	10 A	12 A	16 A	20 A	25 A

Table 5: Fuse size, IEC

Voltage (V)	Frequency (Hz)	Fuse size, J, RK1 or RK5 type			
		G 2 VSD	G 4 VSD	G 5 VSD	G 7 VSD
UL/CSA					
460/3	60	JKS-8, KTS-8 or FRS-R-8	JKS-10, KTS-10 or FRS-R-10	JKS-12, KTS-12 or FRS-R-12	JKS-15, KTS-15 or FRS-R-15

Table 6: Fuse size, UL/CSA

9.3 Reference conditions and limitations

Reference conditions

Characteristic	Unit	Data
Air inlet pressure (absolute)	bar	1
Air inlet pressure (absolute)	psi	14.5
Air inlet temperature	°C	20
Air inlet temperature	°F	68
Relative humidity	%	0
Working pressure	bar(e)	See <i>Compressor data</i>
Working pressure	psi	See <i>Compressor data</i>

Limitations

Characteristic	Unit	Data
Maximum working pressure	bar(e)	See <i>Compressor data</i>
Maximum working pressure	psig	See <i>Compressor data</i>
Minimum working pressure	bar(e)	4
Minimum working pressure	psig	58
Maximum air inlet temperature	°C	46
Maximum air inlet temperature	°F	115
Maximum ambient temperature	°C	46
Maximum ambient temperature	°F	115
Minimum ambient temperature	°C	0
Minimum ambient temperature	°F	32

9.4 Compressor data



NOTE

The data is valid under the reference conditions. See section *Reference conditions and limitations*.

50 Hz 8 bar (116 psi)

Compressor type		G 2 VSD	G 3 VSD	G 4 VSD	G 5 VSD	G 7 VSD
Frequency	Hz	50	50	50	50	50
Maximum (unloading) pressure, Pack	bar(e)	8	8	8	8	8
Maximum (unloading) pressure, Pack	psig	116	116	116	116	116
Maximum (unloading) pressure, Full-Feature	bar(e)	7.75	7.75	7.75	7.75	7.75
Maximum (unloading) pressure, Full-Feature	psig	112	112	112	112	112
Nominal working pressure	bar(e)	7.5	7.5	7.5	7.5	7.5
Nominal working pressure	psig	108	108	108	108	108
Pressure drop over dryer	bar(e)	0.15	0.15	0.15	0.25	0.25
Pressure drop over dryer	psig	2.18	2.18	2.18	3.62	3.62
Maximum pressure	bar(e)	8	8	8	8	8
Maximum pressure	psig	116	116	116	116	116
Maximum motor shaft speed	rpm	3640	3680	3700	3620	3690
Minimum motor shaft speed	rpm	1680	1470	1700	1530	1450

Compressor type		G 2 VSD	G 3 VSD	G 4 VSD	G 5 VSD	G 7 VSD
Set point, thermostatic valve	°C	71	71	71	71	71
Set point, thermostatic valve	°F	160	160	160	160	160
Temperature of air leaving receiver (approx.), Pack	°C	33	33	33	33	33
Temperature of air leaving receiver (approx.), Pack	°F	91	91	91	91	91
Pressure dew-point, Full-Feature	°C	3	3	3	3	3
Pressure dew-point, Full-Feature	°F	37	37	37	37	37
Power input, Pack at maximum working pressure	kW	3.6	4.2	5.2	8	9.9
Power input, Pack at maximum working pressure	hp	4.8	5.6	7	10.7	13.3
Power consumption, dryer at full load	kW	0.24	0.24	0.24	0.26	0.47
Power consumption, dryer at full load	hp	0.32	0.32	0.32	0.35	0.63
Power consumption, dryer at no load	kW	0.16	0.16	0.16	0.19	0.29
Power consumption, dryer at no load	hp	0.22	0.22	0.22	0.26	0.39
Refrigerant type		R513A	R513A	R513A	R513A	R513A
Total amount, refrigerant	kg	0.17	0.17	0.17	0.29	0.35
Total amount, refrigerant	lb	0.37	0.37	0.37	0.64	0.77
Oil capacity	l	2.5	2.5	2.5	3.15	3.15
Oil capacity	US gal	0.66	0.66	0.66	0.83	0.83
Sound pressure level, tank-mounted units (according to ISO 2151 (2004)) at 70% of maximum speed.	dB(A)	59	59	62	62	63
Sound pressure level, tank-mounted units (according to ISO 2151 (2004)) at maximum speed.	dB(A)	67	67	68	70	71

50 Hz 10 bar (145 psi)

Compressor type		G 2 VSD	G 3 VSD	G 4 VSD	G 5 VSD	G 7 VSD
Frequency	Hz	50	50	50	50	50
Maximum (unloading) pressure, Pack	bar(e)	10	10	10	10	10
Maximum (unloading) pressure, Pack	psig	145	145	145	145	145
Maximum (unloading) pressure, Full-Feature	bar(e)	9.75	9.75	9.75	9.75	9.75
Maximum (unloading) pressure, Full-Feature	psig	141	141	141	141	141
Nominal working pressure	bar(e)	9.5	9.5	9.5	9.5	9.5
Nominal working pressure	psig	138	138	138	138	138
Pressure drop over dryer	bar(e)	0.15	0.15	0.15	0.25	0.25
Pressure drop over dryer	psig	2.18	2.18	2.18	3.62	3.62
Maximum pressure	bar(e)	10	10	10	10	10
Maximum pressure	psig	145	145	145	145	145
Maximum motor shaft speed	rpm	3660	3650	3580	3620	3670
Minimum motor shaft speed	rpm	2000	1710	2110	1710	1660
Set point, thermostatic valve	°C	71	71	71	71	71
Set point, thermostatic valve	°F	160	160	160	160	160
Temperature of air leaving receiver (approx.), Pack	°C	33	33	33	33	33
Temperature of air leaving receiver (approx.), Pack	°F	91	91	91	91	91
Pressure dew-point, Full-Feature	°C	3	3	3	3	3
Pressure dew-point, Full-Feature	°F	37	37	37	37	37
Power input, Pack at maximum working pressure	kW	3.7	4.3	5.5	7.7	9.9

Compressor type		G 2 VSD	G 3 VSD	G 4 VSD	G 5 VSD	G 7 VSD
Power input, Pack at maximum working pressure	hp	4.9	5.7	7.4	10.3	13.3
Power consumption, dryer at full load	kW	0.24	0.24	0.24	0.26	0.47
Power consumption, dryer at full load	hp	0.32	0.32	0.32	0.35	0.63
Power consumption, dryer at no load	kW	0.16	0.16	0.16	0.19	0.29
Power consumption, dryer at no load	hp	0.22	0.22	0.22	0.26	0.39
Refrigerant type		R513A	R513A	R513A	R513A	R513A
Total amount, refrigerant	kg	0.17	0.17	0.17	0.29	0.35
Total amount, refrigerant	lb	0.37	0.37	0.37	0.64	0.77
Oil capacity	l	2.5	2.5	2.5	3.15	3.15
Oil capacity	US gal	0.66	0.66	0.66	0.83	0.83
Sound pressure level, tank-mounted units (according to ISO 2151 (2004)) at 70% of maximum speed.	dB(A)	59	59	62	63	63
Sound pressure level, tank-mounted units (according to ISO 2151 (2004)) at maximum speed.	dB(A)	67	67	68	70	71

60 Hz 8 bar (116 psi)

Compressor type		G 2 VSD	G 4 VSD	G 5 VSD	G 7 VSD
Frequency	Hz	60	60	60	60
Maximum (unloading) pressure, Pack	bar(e)	8	8	8	8
Maximum (unloading) pressure, Pack	psig	116	116	116	116
Maximum (unloading) pressure, Full-Feature	bar(e)	7.75	7.75	7.75	7.75
Maximum (unloading) pressure, Full-Feature	psig	112	112	112	112
Nominal working pressure	bar(e)	7.5	7.5	7.5	7.5
Nominal working pressure	psig	108	108	108	108
Pressure drop over dryer	bar(e)	0.15	0.15	0.25	0.25
Pressure drop over dryer	psig	2.18	2.18	3.62	3.62
Maximum pressure	bar(e)	8	8	8	8
Maximum pressure	psig	116	116	116	116
Maximum motor shaft speed	rpm	3640	3700	3620	3690
Minimum motor shaft speed	rpm	1680	1700	1530	1450
Set point, thermostatic valve	°C	71	71	71	71
Set point, thermostatic valve	°F	160	160	160	160
Temperature of air leaving receiver (approx.), Pack	°C	33	33	33	33
Temperature of air leaving receiver (approx.), Pack	°F	91	91	91	91
Pressure dew-point, Full-Feature	°C	3	3	3	3
Pressure dew-point, Full-Feature	°F	37	37	37	37
Power input, Pack at maximum working pressure	kW	3.6	5.2	8	9.9
Power input, Pack at maximum working pressure	hp	4.8	7	10.7	13.3
Power consumption, dryer at full load	kW	0.24	0.24	0.26	0.47
Power consumption, dryer at full load	hp	0.32	0.32	0.35	0.63
Power consumption, dryer at no load	kW	0.16	0.16	0.19	0.29
Power consumption, dryer at no load	hp	0.22	0.22	0.26	0.39
Refrigerant type		R513A	R513A	R513A	R513A
Total amount, refrigerant	kg	See dataplate			
Total amount, refrigerant	lb	See dataplate			
Oil capacity	l	2.5	2.5	3.15	3.15
Oil capacity	US gal	0.66	0.66	0.83	0.83

Compressor type		G 2 VSD	G 4 VSD	G 5 VSD	G 7 VSD
Sound pressure level, tank-mounted units (according to ISO 2151 (2004)) at 70% of maximum speed.	dB(A)	59	62	62	63
Sound pressure level, tank-mounted units (according to ISO 2151 (2004)) at maximum speed.	dB(A)	67	68	70	71

60 Hz 10 bar (145 psi)

Compressor type		G 2 VSD	G 4 VSD	G 5 VSD	G 7 VSD
Frequency	Hz	60	60	60	60
Maximum (unloading) pressure, Pack	bar(e)	10	10	10	10
Maximum (unloading) pressure, Pack	psig	145	145	145	145
Maximum (unloading) pressure, Full-Feature	bar(e)	9.75	9.75	9.75	9.75
Maximum (unloading) pressure, Full-Feature	psig	141	141	141	141
Nominal working pressure	bar(e)	9.5	9.5	9.5	9.5
Nominal working pressure	psig	138	138	138	138
Pressure drop over dryer	bar(e)	0.15	0.15	0.25	0.25
Pressure drop over dryer	psig	2.18	2.18	3.62	3.62
Maximum pressure	bar(e)	10	10	10	10
Maximum pressure	psig	145	145	145	145
Maximum motor shaft speed	rpm	3660	3580	3620	3670
Minimum motor shaft speed	rpm	2000	2110	1710	1660
Set point, thermostatic valve	°C	71	71	71	71
Set point, thermostatic valve	°F	160	160	160	160
Temperature of air leaving receiver (approx.), Pack	°C	33	33	33	33
Temperature of air leaving receiver (approx.), Pack	°F	91	91	91	91
Pressure dew-point, Full-Feature	°C	3	3	3	3
Pressure dew-point, Full-Feature	°F	37	37	37	37
Power input, Pack at maximum working pressure	kW	3.7	5.5	7.7	9.9
Power input, Pack at maximum working pressure	hp	4.9	7.4	10.3	13.3
Power consumption, dryer at full load	kW	0.24	0.24	0.26	0.47
Power consumption, dryer at full load	hp	0.32	0.32	0.35	0.63
Power consumption, dryer at no load	kW	0.16	0.16	0.19	0.29
Power consumption, dryer at no load	hp	0.22	0.22	0.26	0.39
Refrigerant type		R513A	R513A	R513A	R513A
Total amount, refrigerant	kg	See dataplate			
Total amount, refrigerant	lb	See dataplate			
Oil capacity	l	2.5	2.5	3.15	3.15
Oil capacity	US gal	0.66	0.66	0.83	0.83
Sound pressure level, tank-mounted units (according to ISO 2151 (2004)) at 70% of maximum speed.	dB(A)	59	62	63	63
Sound pressure level, tank-mounted units (according to ISO 2151 (2004)) at maximum speed.	dB(A)	67	68	70	71

10 Instructions for use

Oil separator vessel

This vessel can contain pressurized air. This can be potentially dangerous if the equipment is misused.

This vessel must only be used as a compressed air/oil separator tank and must be operated within the limits specified on the data plate.

No alterations must be made to this vessel by welding, drilling or other mechanical methods without the written permission of the manufacturer.

The pressure and temperature of this vessel must be clearly indicated.

The safety valve must correspond with pressure surges of 1.1 times the maximum allowable operating pressure. It should guarantee that the pressure will not permanently exceed the maximum allowable operating pressure of the vessel.

Use only the oil as specified by the manufacturer.

In case of misuse of the units (very low oil temperature or a long shut down interval), a certain amount of condensate can gather in the oil separator vessel which must be properly drained. To do so, disconnect the unit from the power line, wait until it is cooled down and depressurized and drain the water via the oil drain valve, positioned at the bottom of the oil separator vessel.

Local legislation may require a periodic inspection.

Air receiver (tank-mounted units)

Corrosion must be prevented: depending on the conditions of use, condensate may accumulate inside the tank and must be drained every day. This may be done manually by opening the drain valve, or by means of the automatic drain, if fitted to the tank. Nevertheless, a weekly check of correct functioning of the automatic valve is needed. This has to be done by opening the manual drain valve and checking for condensate. Verify that no rust obstructions affect the drain system.

Yearly service inspection of the air receiver is needed, as internal corrosion can reduce the steel wall thickness with the consequent risk of bursting. Local rules need to be respected, if applicable. The use of the air receiver is forbidden once the wall thickness reaches the minimum value as indicated in the service manual of the air receiver (part of the documentation delivered with the unit).

Lifetime of the air receiver mainly depends on the working environment. Installing the compressor in a dirty and corrosive environment is not allowed, as this can reduce the vessel lifetime dramatically.

Do not anchor the vessel or attached components directly to the ground or fixed structures. Fit the pressure vessel with vibration dampers to avoid possible fatigue failure caused by vibration of the vessel during use.

Use the vessel within the pressure and temperature limits stated on the nameplate and the testing report.

No alterations must be made to this vessel by welding, drilling or other mechanical methods.

11 Guidelines for inspection

Guidelines

On the Declaration of Conformity / Declaration by the Manufacturer, the harmonised and/or other standards that have been used for the design are shown and/or referred to.

The Declaration of Conformity / Declaration by the Manufacturer is part of the documentation that is supplied with this compressor.

Local legal requirements and/or use outside the limits and/or conditions as specified by the manufacturer may require other inspection periods.

12 Pressure equipment directives

Components subject to Pressure Equipment Directive (PED)

Components subject to 2014/68/EU PED or Pressure Equipment (Safety) Regulations 2016 - S.I. 2016/1105 greater than or equal to category II:

- Safety valves.

See the spare parts book for part numbers.

Overall rating

The compressors conform to PED smaller than category I.

13 Declaration of conformity

Insert logo here

EU DECLARATION OF CONFORMITY

2 We, **(1)** declare under our sole responsibility, that the product
 3 Machine name :
 4 Machine type :
 5 Serial number :

6 Which falls under the provisions of article 12.2 of the EC Directive 2006/42/EC on the approximation of the laws of the Member States relating to machinery, is in conformity with the relevant Essential Health and Safety Requirements of this directive.

The machinery complies also with the requirements of the following directives and their amendments as indicated.

	Directive on the approximation of laws of the Member States relating to	Harmonized and/or Technical Standards used	Att'mnt
7	(2)	(3)	
a			X
b			
c			X
d			
e			
f			
g			X

8a The harmonized and the technical standards used are identified in the attachments hereafter

8b <1> is authorized to compile the technical file.

	Conformity of the specification to the directives	Conformity of the product to the specification and by implication to the directives
11 Issued by	Engineering	Manufacturing
12 Name		
13 Signature		
14 Date		
15 Place		

84390D

Figure 72: Typical example of a Declaration of Conformity document

- (1)** Contact address:
Atlas Copco Airpower n.v.
P.O. Box 100
B-2610 Wilrijk (Antwerp)
Belgium
- (2)** Applicable directives
- (3)** Standards used

On the Declaration of Conformity / Declaration by the Manufacturer, the harmonized and/or other standards that have been used for the design are shown and/or referred to.

The Declaration of Conformity / Declaration by the Manufacturer is part of the documentation that is supplied with this device.



atlascopco.com

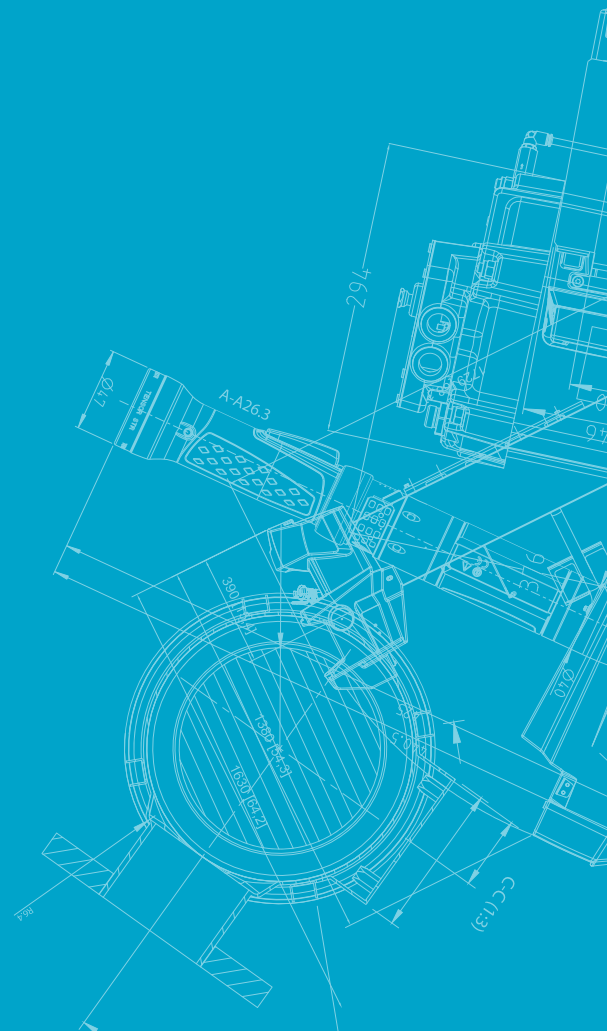

2920 7219 30 - EN © Printed in Atlas Copco Airpower N.V. All rights reserved. Designs and specifications are subject to change without notice or obligation ... November 2023