



**MODEL 1270 - Manual/1260 - Power**  
**Bi-Part Sliding Seamless Molded Fiberglass Door**

<b>GENERAL INFORMATION</b>	3-6
Safety Practices	4
Warranty Policy	5
Crates and Contents	6
<b>1270-1260 MANUAL INSTALLATION</b>	7-29
<b>1270 Manual</b>	
Door Measurements	7
Frame and Header Assembly	8
Panel Installation & Adjustment	10
Cable Reel Adjustment	12
Panel Open Position	13
<b>1260 Power</b>	
Door Measurements	14
Frame and Header Assembly	15
Panel Installation & Adjustment	17
Warning Label Installation	18
Electrical Controls	22
Electrical Equipment	23
Start-Up	26
Activator Signals	26
Programming Parameters	26
<b>MAINTENANCE</b>	30-33
Inspection	30
Preventative	30
Troubleshooting	31
Fault Diagnosis	31
General Fault Table	31
Electrical Fault Table	31
<b>REPLACEMENT PARTS</b>	34-56
Instructions for Ordering	34
Door Identification	35
ID Tag Location	35
Door Assembly	36
Operators	37
Header Assembly	38
Option - Lock	42
Shrouds	46
Molded Door Panel Assembly	48
Laminated Door Panel Assembly	49
Face Frame Assemblies	50
Option - Battery Backup	55
Option - Interlock Module	56

Manual last updated on: October 5, 2022 10:22 AM

## Safety Practices



This is a safety alert symbol. It is used to alert you to potential personal injury hazards. Obey all safety messages that follow this symbol to avoid possible injury or death.

### DANGER

**DANGER** indicates an imminently hazardous situation which, if not avoided, will result in death or serious injury.

### WARNING

**WARNING** indicates a potentially hazardous situation which, if not avoided, could result in death or serious injury.

### CAUTION

**CAUTION** indicates a potentially hazardous situation which, if not avoided, may result in minor or moderate injury.

### CAUTION

**CAUTION** used without a safety alert symbol indicates a potentially hazardous situation which, if not avoided, may result in property damage.

### NOTE

**NOTE** explains general information.

**⚠ WARNING**

**Warning** read these safety practices before installing, operating or servicing the SLIDING door. Failure to follow these safety practices could result in property damage, death or serious injury.

READ AND UNDERSTAND ALL WARNING LABELS AND OPERATING INSTRUCTIONS IN THIS MANUAL BEFORE OPERATING THE SLIDING DOOR. If you do not understand the instructions, ask your supervisor to teach you how to use the SLIDING door.

## Safety Practices (cont'd)

1. Do not operate the door while under the influence of drugs or alcohol.
2. Do not use the door if it looks broken or does not seem to work properly. Advise your supervisor at once.
3. Stay clear of the door when it is moving
4. Keep hands, feet and head clear of the door at all times.
5. Do not operate the door with equipment, material or people directly inside door opening.
6. Disconnect power before performing any electrical or mechanical service, cleaning or other maintenance on the door. OSHA requires disconnect to be properly tagged and locked out during all maintenance or service of equipment. With the power supply disconnected, always verify using a volt meter.
7. All electrical troubleshooting or service must be completed by a qualified electrician or service person and must meet all applicable local, state, federal, international and other governing agency codes.
8. When it is necessary to service the control box with power on, USE EXTREME CAUTION. Do not place fingers or uninsulated tools inside the control box. Touching wires or other parts inside the enclosure may cause electrical shock, serious injury or death.
9. It is your responsibility to keep all warning labels and instructional literature legible, intact and kept with the door. Replacement labels and literature are available from ASI Doors, Inc. or its representatives.
10. If you have any questions, contact your supervisor or your local ASI Doors, Inc. representative for assistance.
11. Train all service and personnel using or near door on intended use(s) and operation of the door.
12. Failure to operate the door as intended, as described, or heed any warning may result in equipment damage, property damage, serious bodily injury or death.

## Warranty Policy

ASI Doors (herein called “ASI”) warrants solely for the benefit of its customer that each door system manufactured by ASI (each a “Door System”) will be free from defects in material and manufacture for a period of one (1) year from the date of original shipment by ASI. The following models receive a similar two (2) years from date of shipment warranty: 109, 209, 120-125, 1240-125-, 1240SS-1250SS, 1260-1270, 1260SS-1270SS, 130-135, 140-150, 160-170, 220-225, 220SS-225SS, 230-235, 230SS-235SS. In all instances warranty labor is covered for a period of one (1) year from the date of original shipment.

The foregoing limited warranty shall not apply to defects that result from improper installation, abuse, misuse, alteration, modification, or failure to maintain the Door System in accordance with the ASI Owner’s Manual. Periodic maintenance and adjustment of the Door System as described in the ASI Owner’s Manual are the sole responsibility of the customer. All claims for defects must be made to ASI within thirty (30) days after the defect is discovered or should, with reasonable care, have been discovered. **THE FOREGOING LIMITED WARRANTY CONSTITUTES THE EXCLUSIVE WARRANTY OF ASI WITH RESPECT TO THE DOOR SYSTEM. ASI EXPRESSLY DISCLAIMS ALL OTHER GUARANTEES OR WARRANTIES—WHETHER EXPRESSED, IMPLIED, OR STATUTORY, INCLUDING BUT NOT LIMITED TO ANY IMPLIED WARRANTY OF MERCHANTABILITY AND FITNESS FOR A PARTICULAR PURPOSE.**

If a Door System does not comply with the foregoing limited warranty, and a claim is made by customer within the warranty period, ASI will, at the option of ASI, either repair or replace any defective equipment or parts free of charge and pay the reasonable labor costs to repair or replace the defective equipment or parts if within the defined warranty period. The remedy of repair or replacement shall be the exclusive and sole remedy for any breach of the foregoing limited warranty.

**ASI SHALL NOT IN ANY EVENT BE LIABLE FOR ANY INCIDENTAL, INDIRECT, SPECIAL, EXEMPLARY OR CONSEQUENTIAL DAMAGES OF ANY KIND, INCLUDING WITHOUT LIMITATION ANY LOST PROFITS, ARISING FROM THE SALE OR USE OF THE DOOR SYSTEM, OR FROM ANY OTHER CAUSE WHATSOEVER, WHETHER THE CLAIM GIVING RISE TO SUCH DAMAGES IS BASED UPON BREACH OF WARRANTY (EXPRESSED OR IMPLIED) BREACH OF CONTRACT, TORT, STRICT LIABILITY OR ANY OTHER THEORY OF LIABILITY, EVEN IF A PARTY HAS BEEN ADVISED OF THE POSSIBILITY THEREOF, AND REGARDLESS OF ANY ADVISE OR REPRESENTATION THAT MAY HAVE BEEN RENDERED BY ASI CONCERNING THE SALE OR USE OF THE DOOR SYSTEM.**

At ASI’s request, customer shall return to ASI for inspection any Door System for which a warranty claim has been made, F.O.B. ASI’s facility with freight prepaid. The customer is responsible for any removal costs.

The customer shall comply with the following procedures in filing a warranty claim with ASI:

1. Notify ASI of any and all defects in writing with photographic evidence. ASI will review the warranty request and issue a Returns Merchandise Authorization (RMA) form if the defective parts need to be returned to ASI for inspection and verification. The RMA form must accompany any materials returned for warranty consideration.
2. All replacement parts or equipment will be invoiced to the customer. Upon verification by ASI that the Door System is defective, ASI will issue a full credit to customer for the replacement parts or equipment.
3. If outside labor is needed to install the replacement parts or equipment, ASI requires a written estimate of the labor charges in advance so ASI may approve the labor charges and issue a purchase order. ASI will not accept any labor charges unless previously approved in writing and accompanied by the ASI purchase order number.

(Rev 12/21)

# Crates and Contents

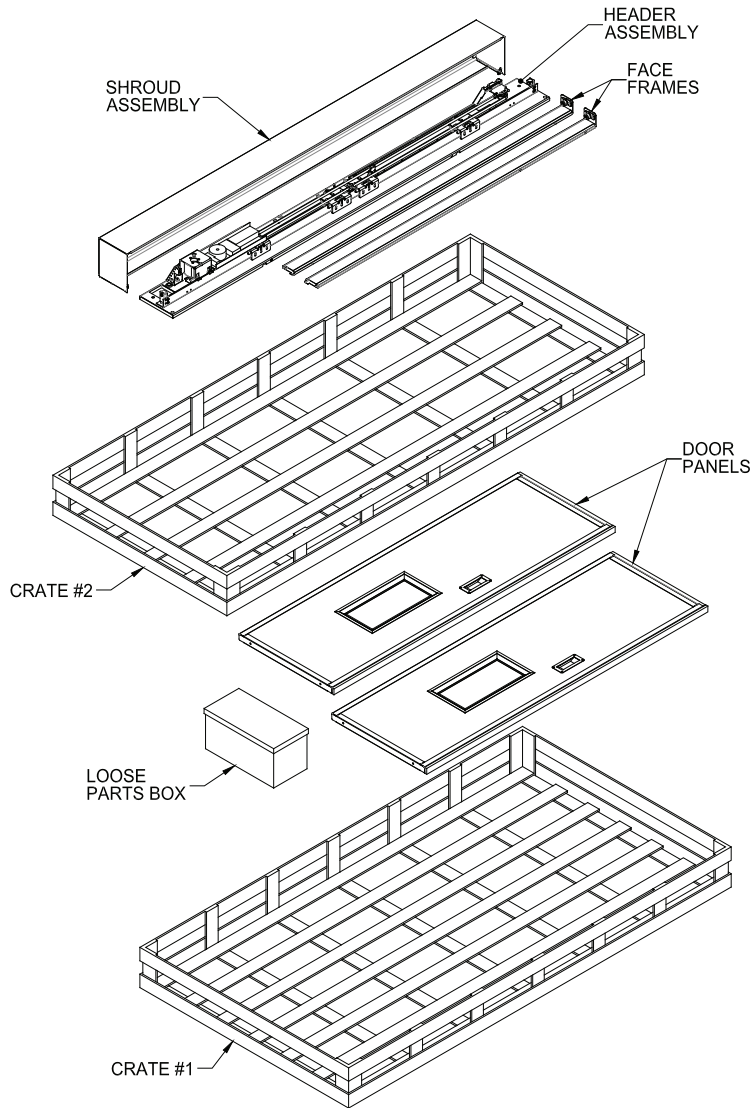

Upon receipt of the shipment, check that you have received the correct number of pieces as shown (figure 1). Crate will contain the side-covers, the header assembly, the loose parts box, and control box. For your protection, note any damages or shortages on the carrier’s bill of lading before signing the bill for receipt.

The installation of this door will require at least a two man crew and a fork-lift. Select a fork-lift with lifting height based upon the height of the door, plus a minimum additional two feet.

## NOTE

Because of variances in the construction of walls on which the door will be mounted, fasteners are not supplied. For proper anchoring of the door, we recommend the use of thru-bolts. **DO NOT** remove door sections from crate until you encounter the step in which they are to be installed.

## Loose Parts

Description	Qty.
Installation Instructions	1
Warning Nameplate Assembly	2
Misc. Hardware	-
Misc. Activation Devices	-

# Door Measurements

1. Measure door opening to verify door dimensions (Figure 3). Based upon dimensions in Figure 3, determine that door will have sufficient wall space to open. Locate side frames relative to the sides of the opening as shown in Figure 2.

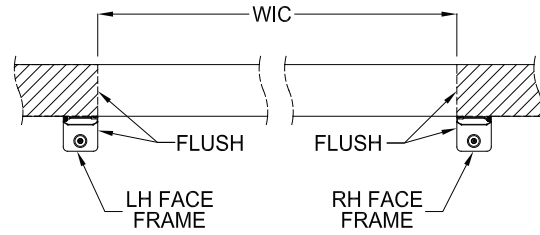

Figure 2: Wall Clip Position

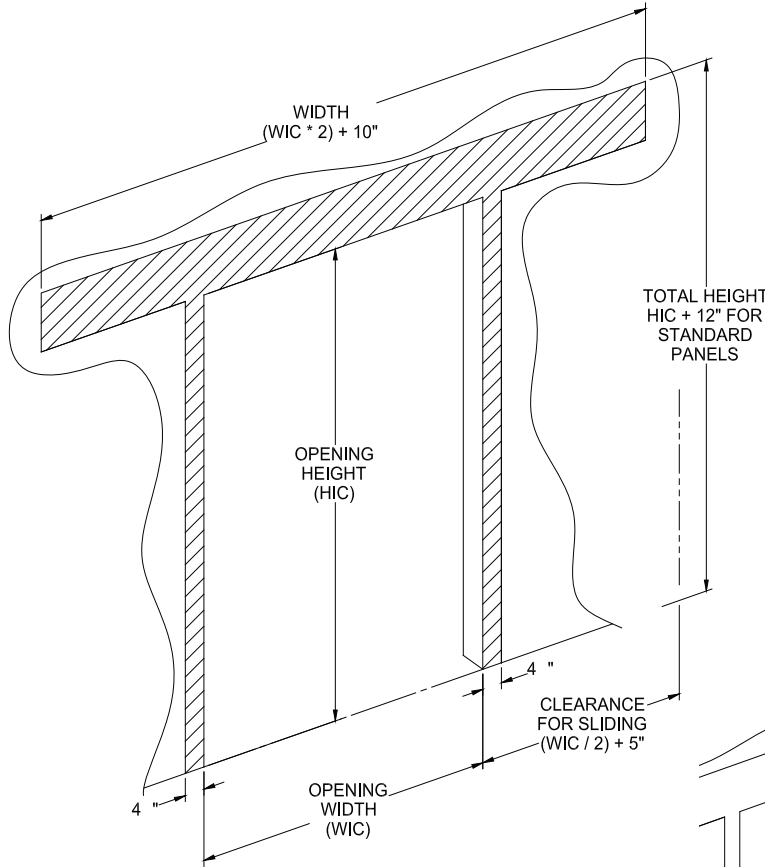

Figure 3: Door Measurements

## NOTE

**Note** illustrations on the following pages show installation for right hand slide doors. For left hand doors, components will be mounted opposite.

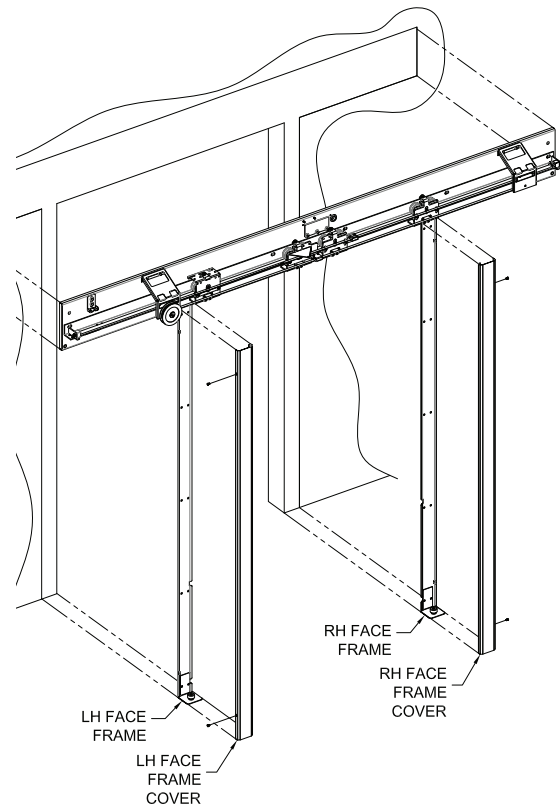

Figure 5: Mounting Header and Face Frames

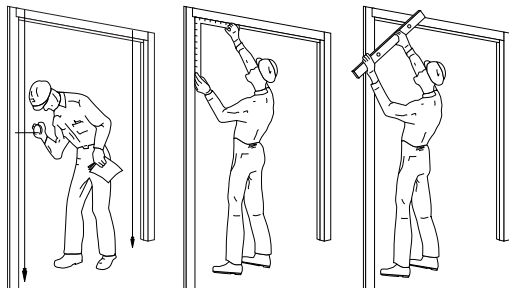

Figure 4: Checking Plumb and Square

# Face Frame Installation

## NOTE

**Note** determine if the floor is level. If the floor is not level, install the wall clip on the high side of the opening.

1. Attach the wall clips to the wall through the mounting holes provided (Figure 6). Be sure that the clips are plumb. This is critical for proper gasket seal (Figures 2 & 4).

## NOTE

**Note** recheck wall clips to be sure they are plumb and level. Make any necessary adjustments.

2. Attach the face frame covers to the face frame wall clips with screws at locations shown in Figure 6 & Figure 7.

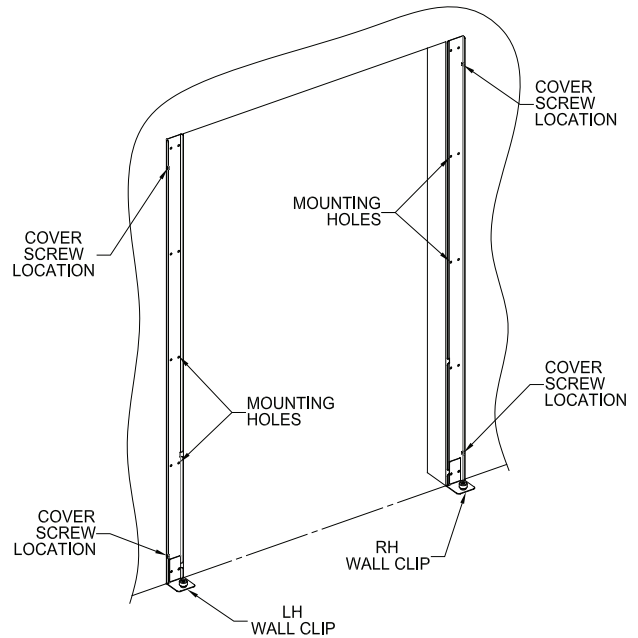

Figure 6: Installing Wall Clips to opening.

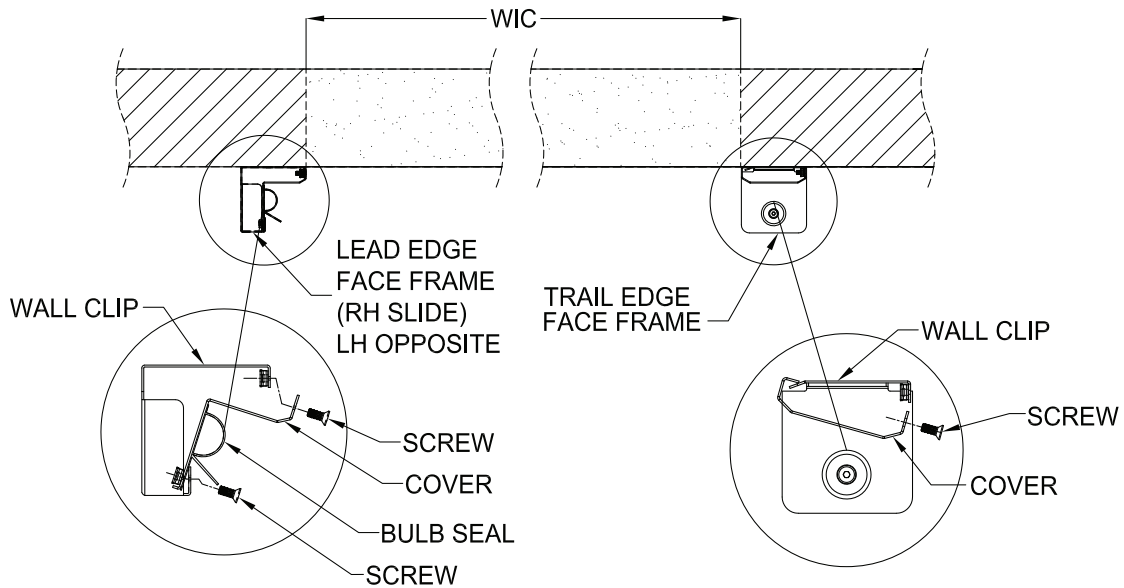

Figure 7: Fastening Face Frame Covers to Wall Clips

# Header Installation

## ⚠ WARNING

**Warning** when mounting rail, keep personnel out of the area below the header until the rail is secured to the wall. Failure to do so could result in property damage, death or serious injury.

3. Remove the shroud from the header by removing screws on the shroud and 4 screws on the bottom splice bracket.
4. Position the header on top of the wall clips, and center it on the door opening.
5. Mount the header to the wall. Use the holes provided in the header to mount it to the wall.

## NOTE

**Note** we strongly recommend that thru-holes be drilled for proper anchoring of the door to the wall.

## ⚠ CAUTION

**Caution** improper installation of anchoring devices, installation into aged or unsound concrete or mounting to a non-plumb wall without proper shimming; could result in premature product wear or product failure. Failure to properly install equipment could result in property damage.

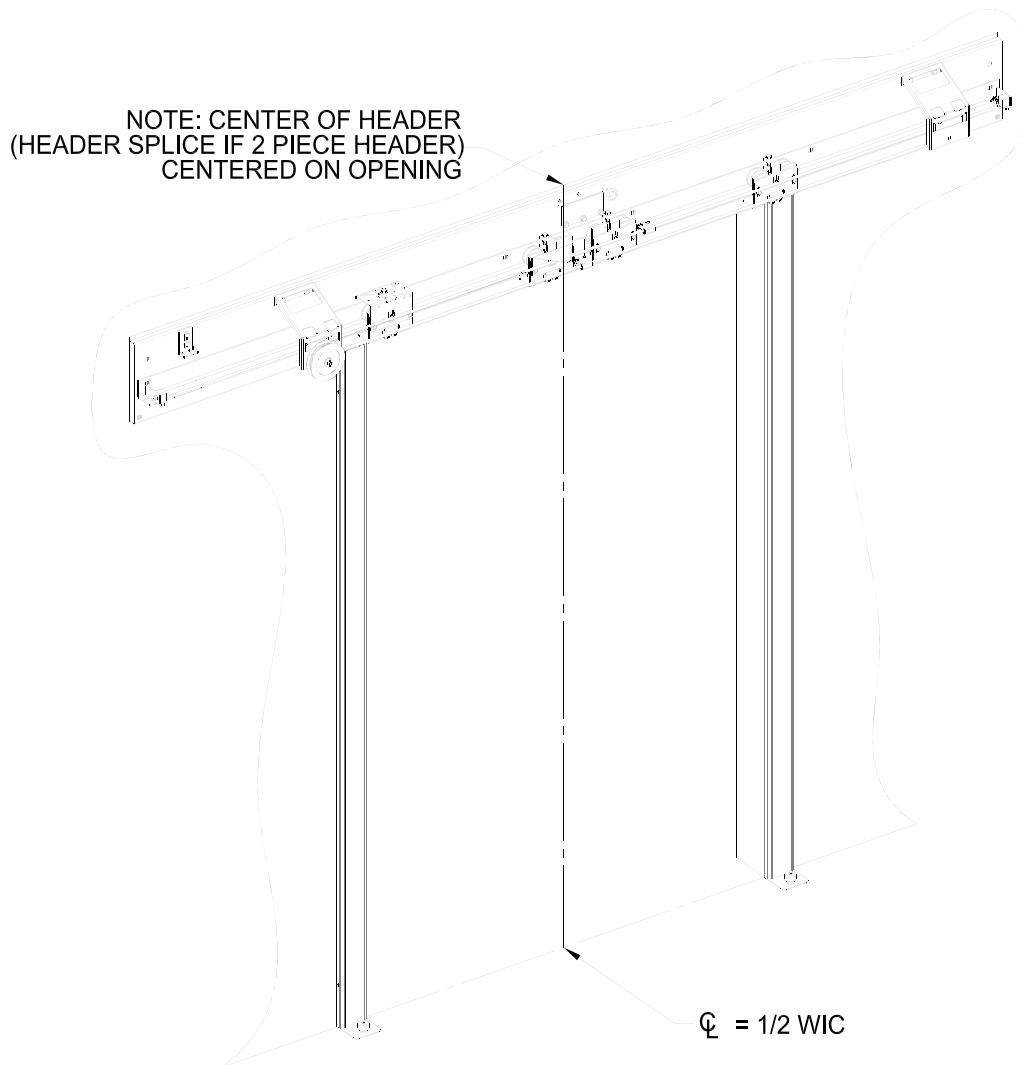

Figure 8: Positioning the Header

## Panel Installation and Adjustment

1. Loosen the two horizontal panel adjusting bolts on top of each panel(s). These bolts will slide between the two forks on the panel trolley bracket in the header (Figures 9 & 10).
2. Measure the distance between the mounting bolts on the panel and manually position the panel trolleys the same distance apart in the header.
3. Manually position the bottom of the panel over the guide roller. Then move the panel into position so the two adjusting bolts are located on the forks of the panel trolleys.
4. Position the panel horizontally to provide a consistent seal and tighten the horizontal panel adjusting bolts.
5. Back off the roller trolley locking bolts on both panel trolleys and use the vertical panel adjustment bolts to position the panel at the desired height. The panel gasket should have contact with the floor for proper sealing. Tighten the locking bolts to secure the panel. Make sure there is clearance between rail and both anti-jump tabs on both trolleys, see Fig. 9.

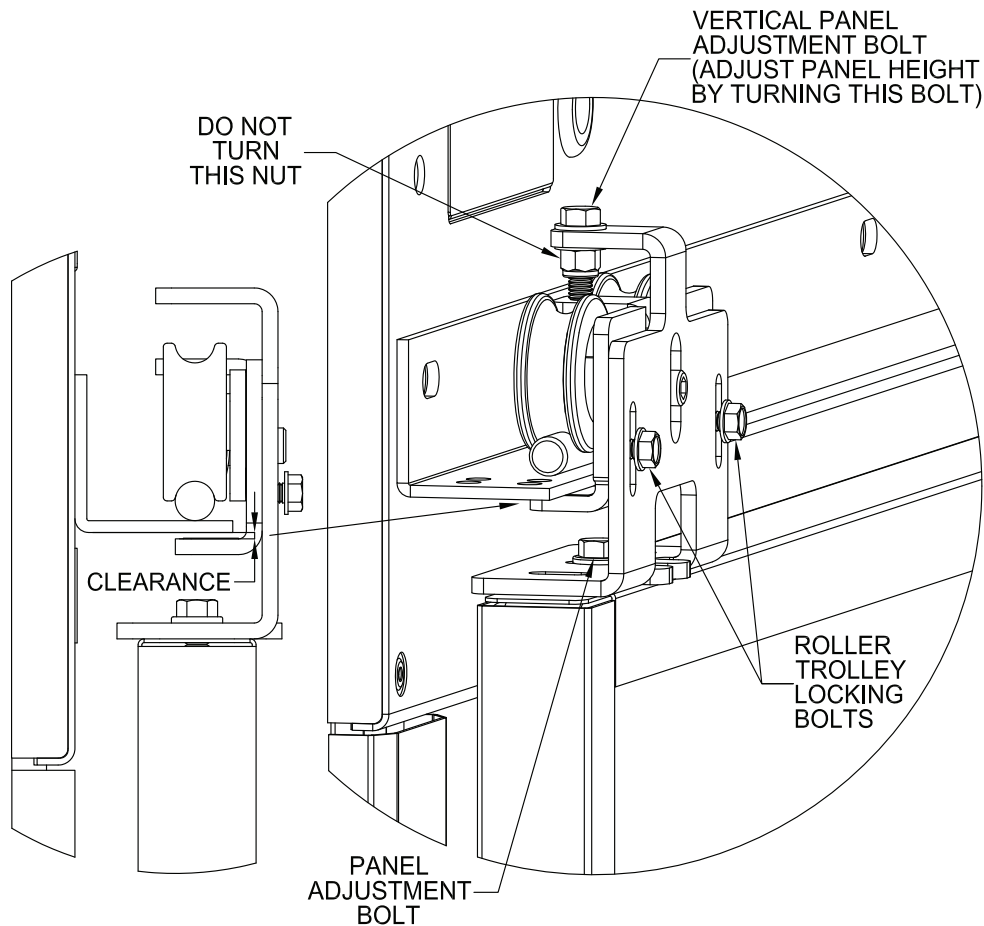

Figure 9: Attaching Panel to Header

## Panel Installation and Adjustment Continued

6. Manually operate the door and visually inspect to ensure the gasket is making contact around the perimeter of the opening. Make any adjustments necessary to maintain a seal.
7. Manually operate the door and visually inspect to ensure the gasket is making contact around the perimeter of the opening. Make any adjustments necessary to maintain a seal.
8. Manually operate the door panels open and closed. Verify that door panels clear the opening and contact bumpers at the end of open and close travel.

### NOTE

**NOTE** minimal contact is all that is necessary to provide a tight seal. This will also extend the life of the gasket.

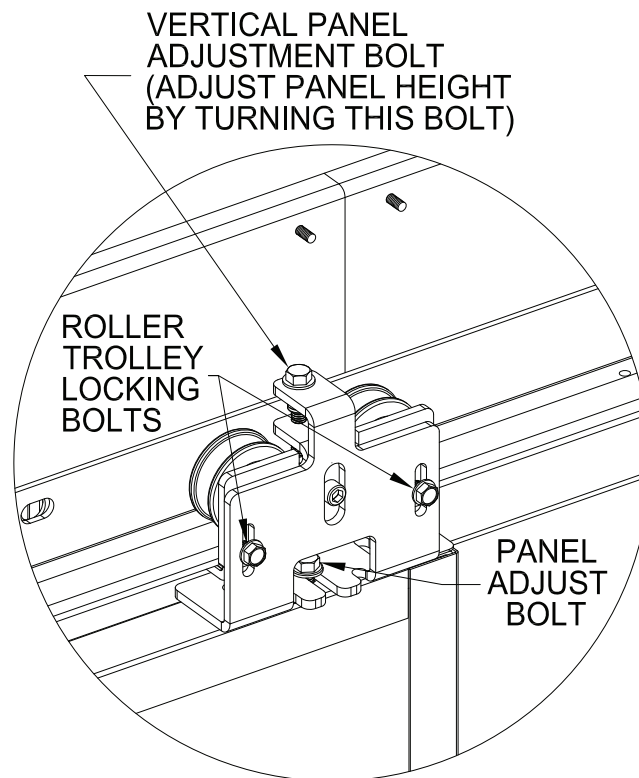

Figure 10: Adjusting Bolt Locations

# Cable Reel Adjustment

1. Tension Cable is attached from Cable Reel to Cable Return bracket on lead edge Trolley (Figure 11). To adjust tension on cable, rotate cable reel manually to create slack on cable, and increase the number of windings of cable on the Cable Reel (Increases tension), or reduce the number of windings of cable on the Cable Reel (Decreases tension).

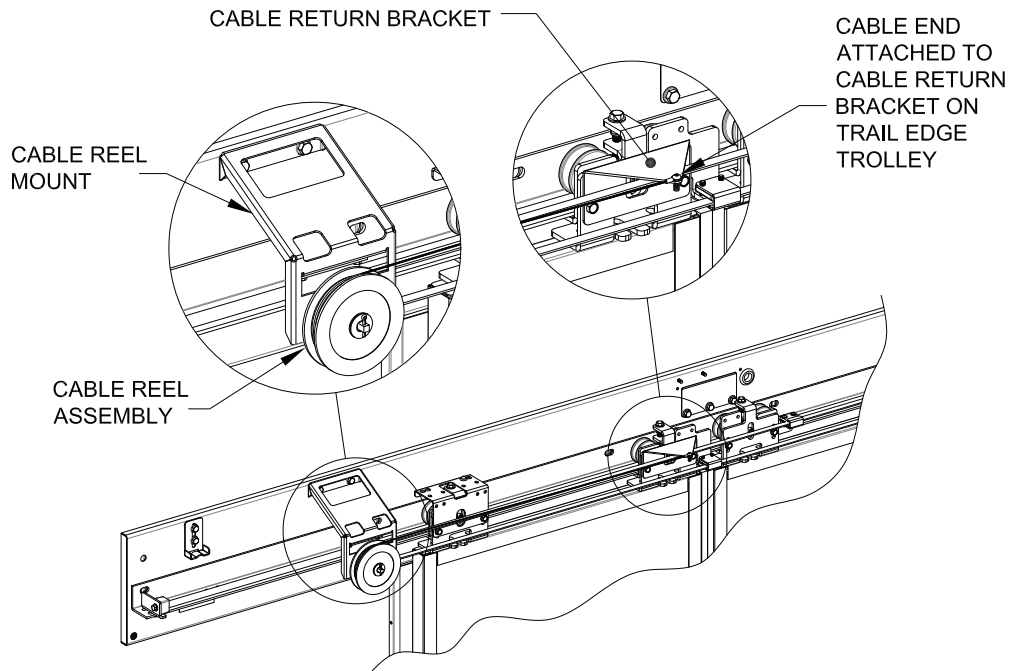

Figure 11: Cable Reel Adjust & Closed Door Position

# Panel Open Position Adjustment

1. A spring plunger is installed in the detent/stop bracket on the trail edge trolley. This plunger fits into the notch in the detent bracket, mounted on the header, and locks the door in the open position (see Fig. 12).
2. Adjust the force needed to close door by adjusting the vertical position of the detent bracket on the header. Loosen bolts holding header detent bracket, and lower bracket (Increases tension), or raise bracket (Decreases tension). Re-tighten bolts after adjusting position.

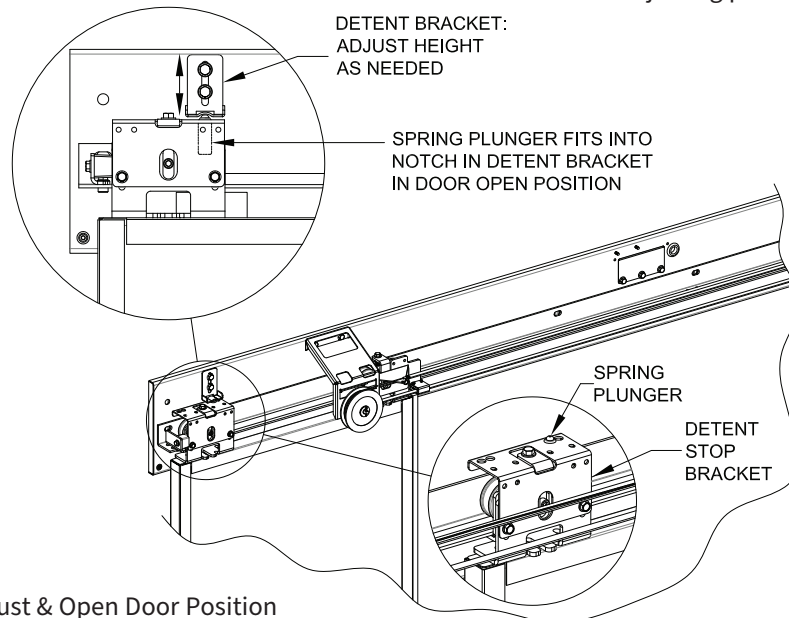

Figure 12: Detent Adjust & Open Door Position

# Door Measurements

1. Measure door opening to verify door dimensions (Figure 3). Based upon dimensions in Figure 3, determine that door will have sufficient wall space to open. Locate side frames relative to the sides of the opening as shown in Figure 2.

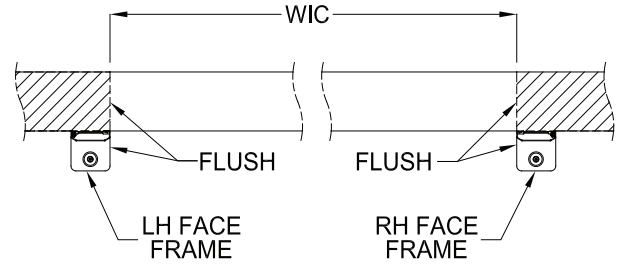
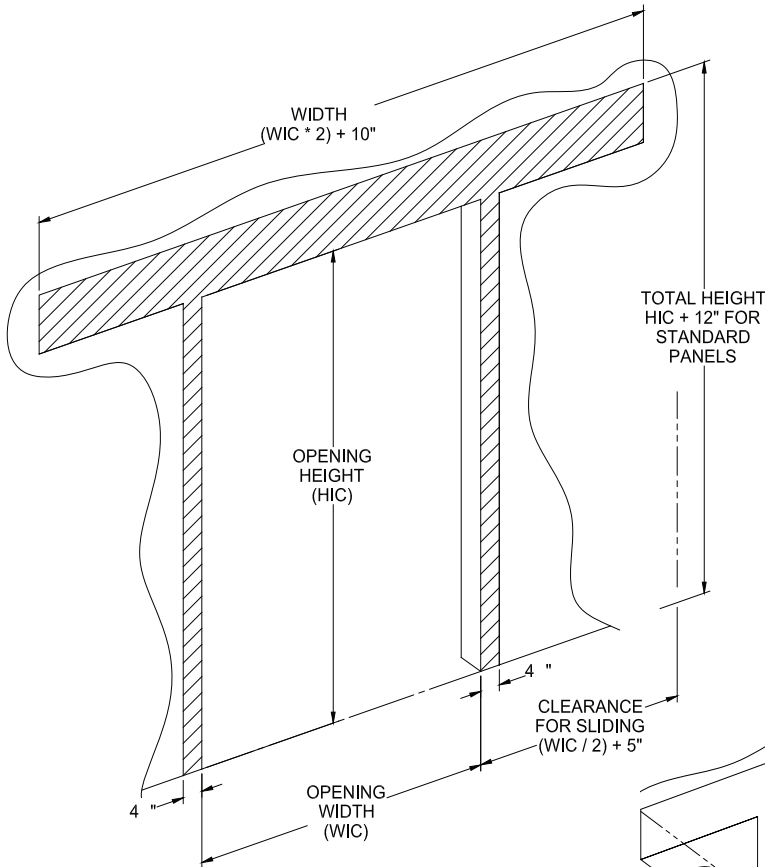

Figure 13: Wall Clip Position



**NOTE**

**Note** illustrations on the following pages show installation for right hand slide doors. For left hand doors, components will be mounted opposite.

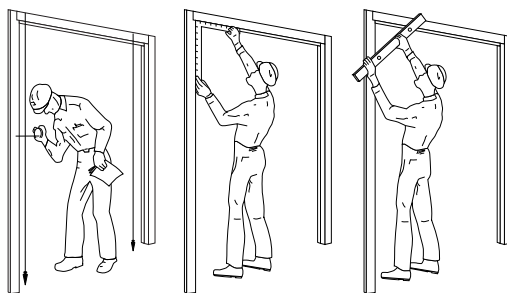

Figure 15: Checking Plumb and Square

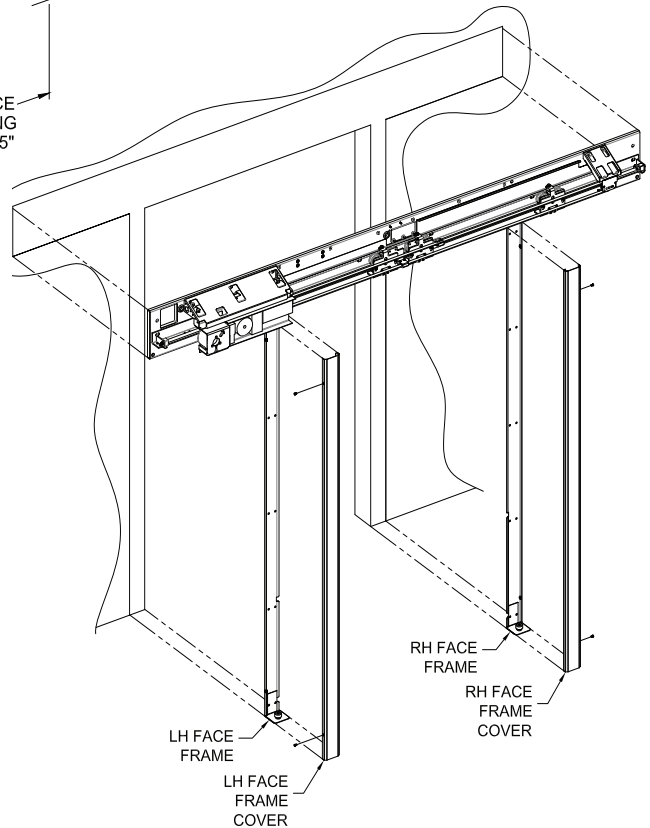

Figure 16: Mounting Header and Face Frames

# Frame and Header Assembly

## NOTE

**Note** determine if the floor is level. If the floor is not level, install the wall clip on the high side of the opening.

**Note** we strongly recommend that thru-holes be drilled for proper anchoring of the face frames to the wall. Recheck wall clips to be sure they are plumb and level. Make any necessary adjustments.

1. Attach the wall clips to the wall through the holes provided. Be sure that the clips are plumb. This is critical for proper gasket seal (Figures 13 & 15).
2. Locate photoeye cables on back of header and identify each pair of wires by its location near the grommets in the bottom edge of the header (Figure 19). You will be connecting these wires to one emitter and receiver on each side frame. Remove the emitter and receiver heads from each wire for installation into face frames. Route the cables in pairs through the grommets in the header as shown.
3. For a right hand slide, position the left edge of the header (w/o shroud) flush with the left edge of the lead edge face frame (Figure 18). For a left hand slide, position the right edge of the header (w/o shroud) flush with the right edge of the lead edge face frame.
4. Mount the header to the wall. Use the holes provided in the header to mount it to the wall.

## ⚠ WARNING

**Warning** when mounting header, keep personnel out of the area below the header until it is secured to the wall. Failure to do so could result in property damage, death or serious injury.

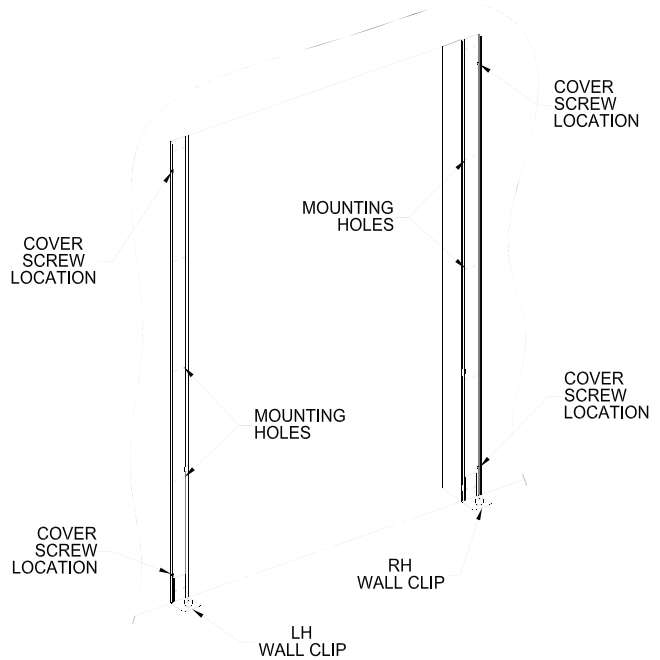

Figure 17: Installing Wall Clips To Opening

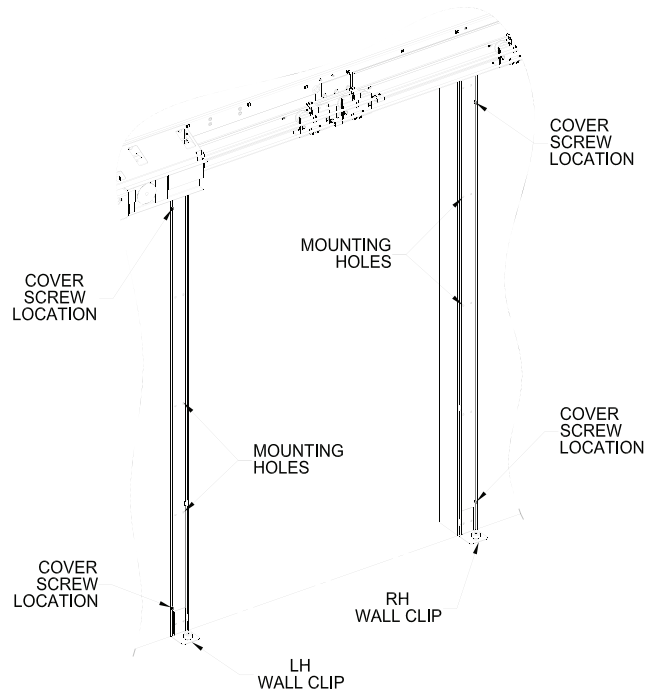

Figure 18: Positioning the Header

## CAUTION

**Caution** improper installation of anchoring devices, installation into aged or unsound concrete or mounting to a non-plumb wall without proper shimming; could result in premature product wear or product failure. Failure to properly install equipment could result in property damage.

## NOTE

**Note** make sure the photoeye cables come out of holes provided in the bottom of the header and do not get cut or pinched during positioning.

- Mount photoeye sensors as shown in Figure 19. Pay attention to colors of photoeye wires (Figure 20).
- Connect the photoeye emitter and receiver leads to the same color wires from the header. The wires are color-coded black or gray. Emitters are gray and receivers are black. Match wire colors and install the photoeyes as shown in Figure 20.

## NOTE

**Note** the emitter cable (gray) can be shortened or lengthened, the receiver cable (black) may only be shortened but not lengthened.

- Use self-adhesive clamps and ties provided to hold the wiring in place and contain any extra length of wire.
- Attach the face frame covers to the face frame wall clips with screws at locations shown in Figure 21 & 22.

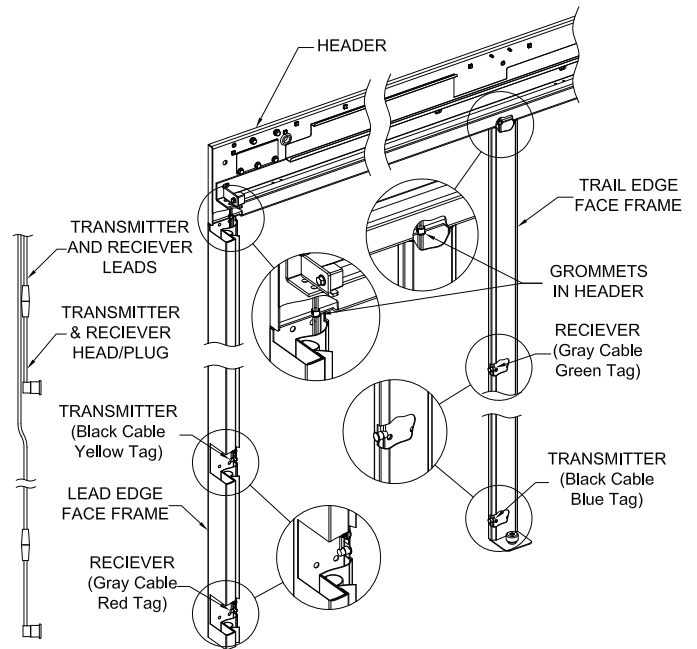

Figure 19: Photoeye Wire Routing

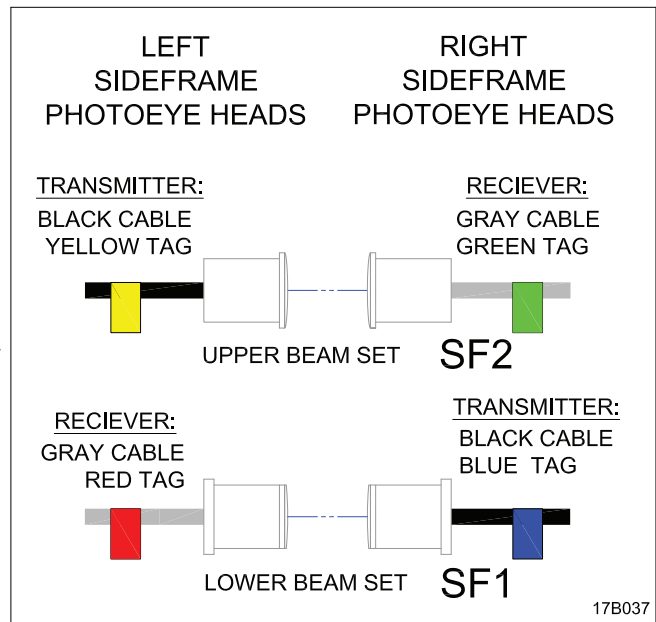

Figure 20: Photoeye Wire Color Codes

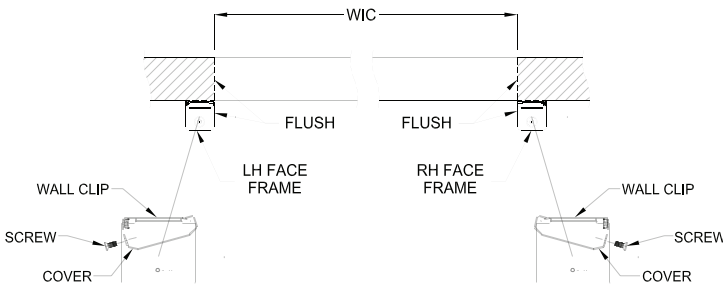

Figure 21: Fastening Face Frame Covers to Wall Clips

## Frame and Header Assembly Continued

- Connect the power cord to the 115VAC grounded power inlet on the CONTROL UNIT (Page 25, Figure 29). Verify that the voltage setting on the control unit is set to 115VAC. Then route the cord through the header and out to the power source.
- Make sure the edges of all routing holes of the power cord are smooth and have any burrs removed. Use tie wraps or clips to make sure power cord is secure inside the header, and will not contact any moving parts inside the header.

### NOTE

**Note DO NOT** plug into 115 VAC power at this time.

SF1  
PHOTOCELL 1  
SAFETY CLOSING 1  
W/REVERSING  
CODE 642  
SF2  
PHOTOCELL 2  
SAFETY CLOSING 2  
W/REVERSING  
CODE 65C

### TERMINAL BLOCK A SAFETIES

SF 1				SF 2			
1 GND	2 IN	3 OUT	4 24V	5 GND	6 IN	7 OUT	8 24V
○	○	○	○	○	○	○	○
○	○	○	○	○	○	○	○

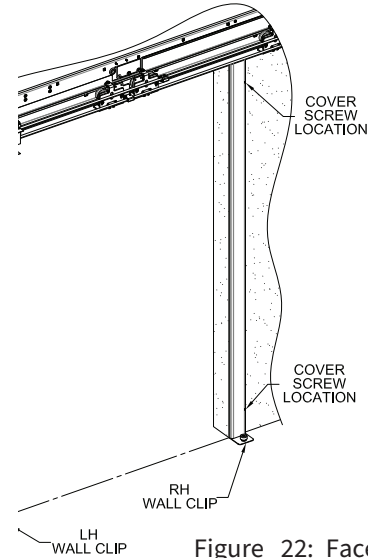

Figure 22: Face Frame Covers

## Panel Installation and Adjustment

- Loosen the two horizontal panel adjusting bolts on top of each panel(s). These bolts will slide between the two forks on the panel trolley bracket in the header (Figures 23 & 24).
- Measure the distance between the mounting bolts on the panel and manually position the panel trolleys the same distance apart in the header.
- Manually position the bottom of the panel over the guide roller. Then move the panel into position so the two adjusting bolts are located on the forks of the panel trolleys.
- Position the panel horizontally to provide a consistent seal and tighten the bolts.

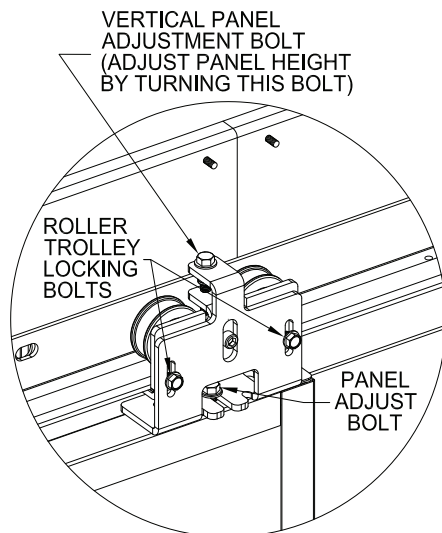

Figure 23: Adjusting Bolt Locations

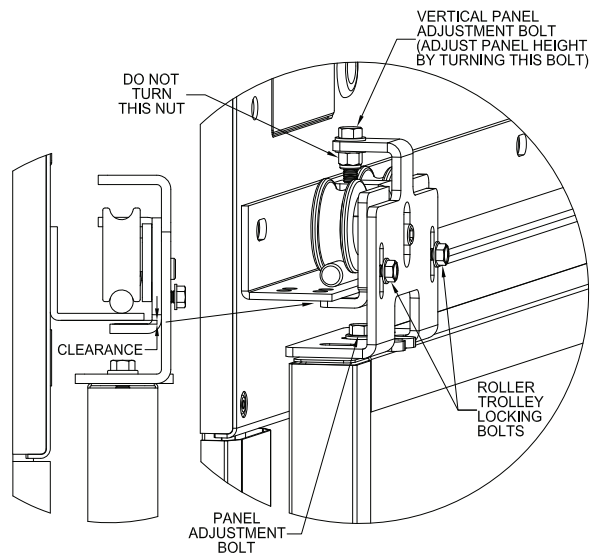

Figure 24: Attaching Panel to Header

## Panel Installation and Adjustment Continued

Back off the locking bolts on both panel trolleys and use the vertical panel adjustment bolts to position the panel at the desired height. The panel gasket should have contact with the floor for proper sealing. Make sure there is clearance between rail and both anti-jump tabs on both trolleys, see Figure 24 on page 21.

Tighten the locking bolts to secure the panel.

### NOTE

**Note** minimal contact is all that is necessary to provide a tight seal. This will also extend the life of the gasket.

6. Manually operate the door and visually inspect to ensure the gasket is making contact around the perimeter of the opening. Make any adjustments necessary to maintain a seal.
7. Manually operate the door panels open and closed. Verify that door panels clear the opening and contact bumpers at the end of open and close travel.

### Warning Label Installation

1. Install warning label (Figure 25) to wall as shown in Figure 26.

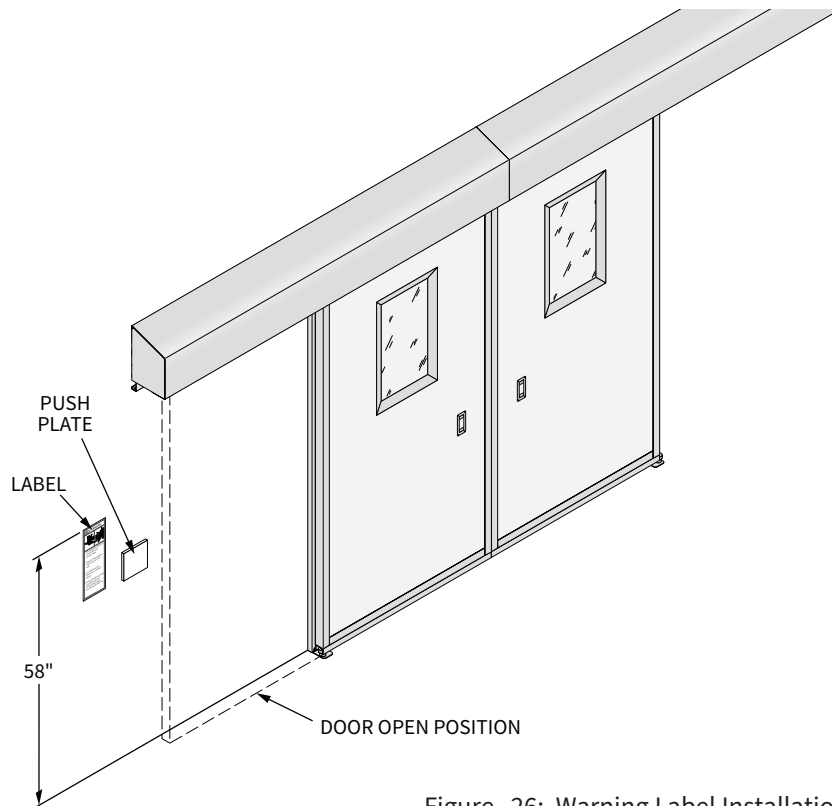

Figure 26: Warning Label Installation

### NOTE

**Note** do Not apply where door panel will cover when door panel is open. Apply warning label next to push plate.

# Electrical Controls

## ⚠ WARNING

**WARNING** control box contains HIGH VOLTAGE! The following procedures should be performed by qualified electrical personnel only. Wiring must meet all local, state, federal and international, or other governing agency codes. Failure to do so could result in death or serious injury.

The microprocessor control system is designed specifically for ASI Doors. The microprocessor programmed self-diagnostic features convey both door status and troubleshooting indicators through individual letter & number codes. Additional inputs are available for automatic door opening. Troubleshooting time is significantly reduced since the letter & number codes direct you to specific problems. Initial electrical hookup is made easy with conveniently located plug-in type 115 VAC power connectors (shipped in loose parts box).

### INPUT POWER

The nominal supply voltage for the control panel is 115 VAC. Be sure to verify this voltage supply is available. The control unit provides 24V DC for other sensing and electrical devices.

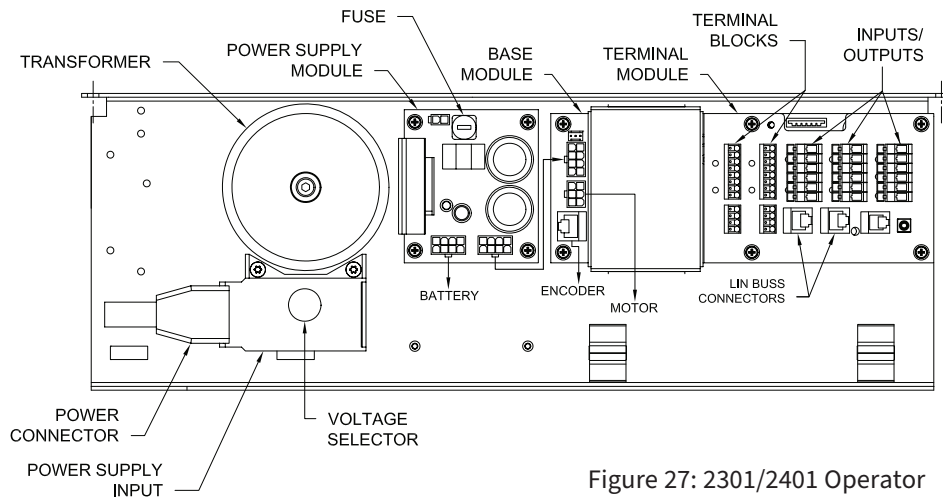

Figure 27: 2301/2401 Operator

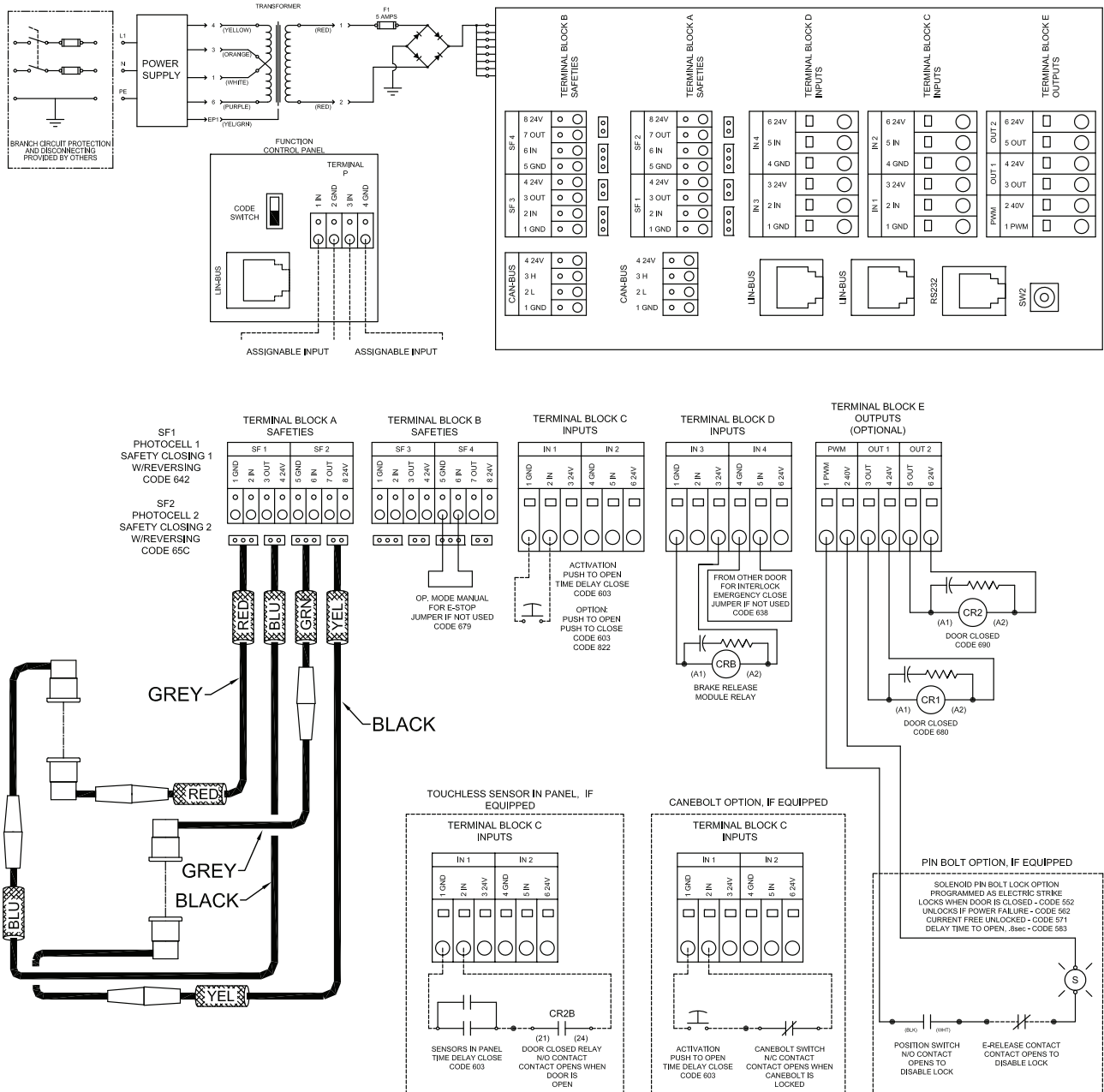

Figure 28: Operator Wiring Schematic

Electrical Schematic drawing # 18D248

## NOTE

**Note** standard schematic shown. Refer to drawing shipped with your specific door.

## ⚠ WARNING

**WARNING** control box contains HIGH VOLTAGE! The following procedures should be performed by qualified electrical personnel only. Wiring must meet all local, state, federal and international, or other governing agency codes. Failure to do so could result in death or serious injury.

MAIN POWER CONNECTION: The door is supplied with a grounded power cord connector.

1. Check that all edges of feed-through holes for the power cable are smooth and have no burrs.

## ⚠ WARNING

**WARNING** disconnect power at the fused disconnect during all electrical or mechanical service. Disconnect must be properly locked out during maintenance or service of equipment. Failure to disconnect power could result in death or serious injury.

2. Check the correct setting of the voltage selector (Figure 29).

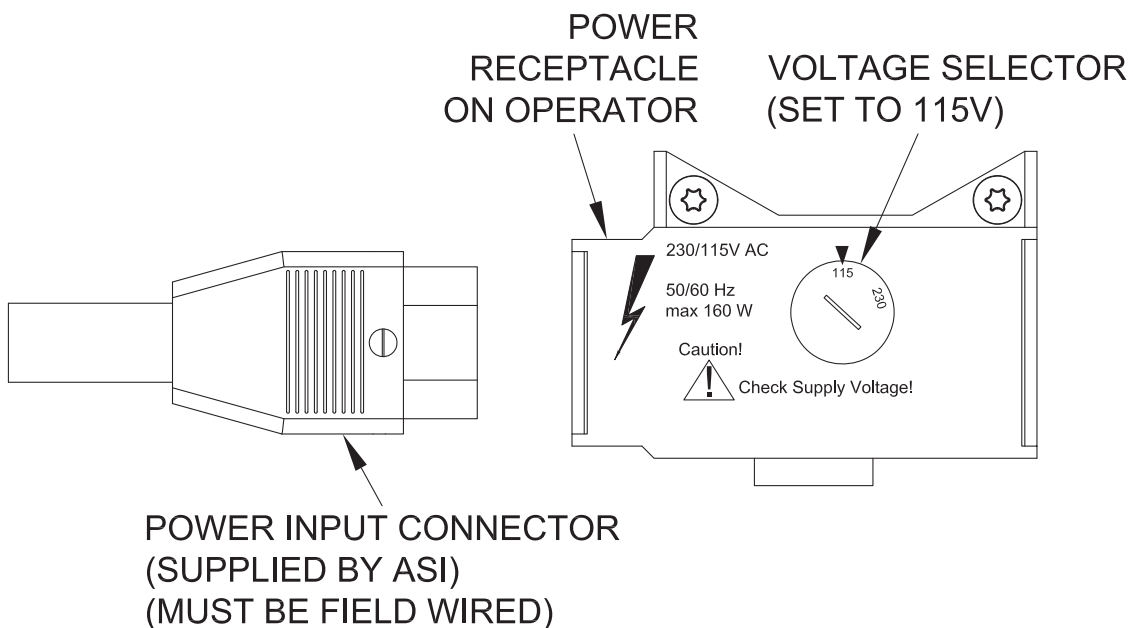

Figure 29: Power Input Connection

## NOTE

**Note** power cable NOT supplied by ASI.

### REVERSING PHOTOEYE:

1. Confirm the wiring to the photo eyes is intact as shown in Figure 30.

## NOTE

**Note** the length of the photoeye cables must not exceed 19'. Do not extend the cable supplied by ASI!

2. Confirm jumper for the emergency stop switch is installed as shown in Figure 30.

## NOTE

**Note** remove the jumper between D1 and D2 if emergency stop switch is used.

3. Connect wiring from wall mount push plates as shown in Figure 31.

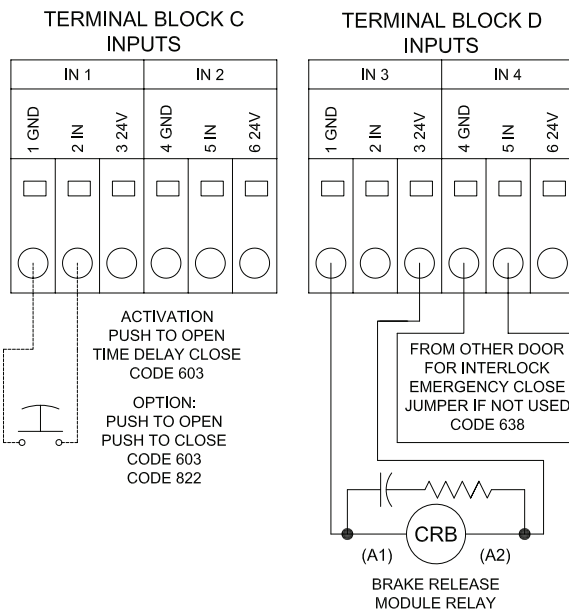

Figure 31: Electrical Input Connections

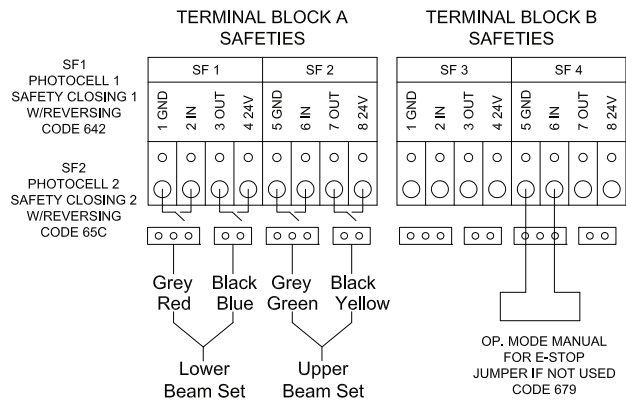

Figure 30: Photoeye & E-Stop Connections

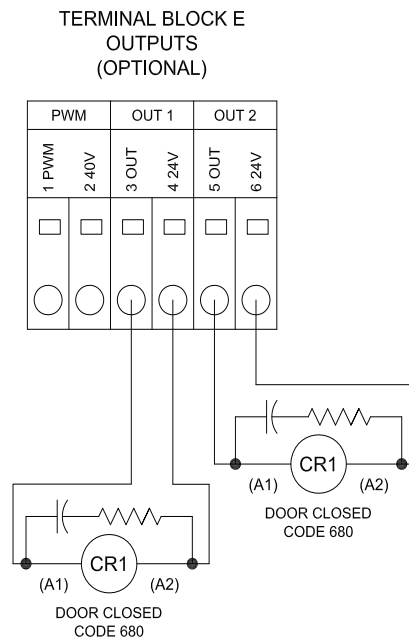

Figure 32: Electrical Output Connections

# Electrical Equipment

## OVERALL DRIVE/CONTROL SYSTEM

### 2301/2401 Control Unit:

This controller is a self-contained door operating unit with a power transformer, motor, brake and clutch. It opens and closes the door panels with a timing belt drive and provides controlled acceleration and deceleration of the door panels for long drive life. It also provides 24V DC to operate optional activating devices. The microprocessor has self-diagnostic capabilities to alert the user to any operational problems.

**Function Control Panel:** this panel which is mounted inside the header provides a touch pad for adjusting operating parameters of the door opening and closing cycle.

## CONTROL INPUTS

1. The 2301/2401 control has a limited number of wiring inputs, since it needs no limit switches or reversing edge wiring. The terminal strip that accepts external wiring is located at the right side of the control.
2. If the photoeye is operating properly a green LED is on and it will go off if the beam is interrupted or connected incorrectly.
3. The function control panel provides the means to make adjustments to the operating parameters of the door. Since it is remotely located from the control, it has a cable that plugs into a terminal strip on the right side of the control.

**Reversing Photoeye:** two photoeye sets are provided standard on all automatic doors.

**Electronic Reversing:** during opening or closing, the door is monitored by electronic circuits. If the door encounters an obstruction during closing, it reverses and reopens, remains open for a short period, then closes again with reduced speed. If the door encounters an obstruction during opening, it reverses and runs in closing direction for a few inches, stops for awhile and closes (opens if an activator signal is received) with a reduced speed.

**Fault Diagnosis:** the microprocessor control continuously monitors performance and will display operating faults through a combination of letter & number codes. See the listing of fault codes starting on page 39.

### WARNING

**Warning** read and understand the start-up procedure in this manual before attempting to power-up the door. Failure to do so could result in damage to the door, personal injury and will nullify all warranties.

1. Position the door in the closed position.
2. Locate the function control panel. Plug the connector into the receptacle in the control. Secure the excess cable and bracket so that the door can be operated without contacting the bracket or excess cable.
3. Turn on the power disconnect or plug in the power cord into a grounded outlet. Make sure the cord is routed to prevent contact with any moving parts.
4. Locate and familiarize the function keypad. The function keypad is used for all programming.

### NOTE

**Note** all reversing photoeyes have been tested at the factory and require only field connection.

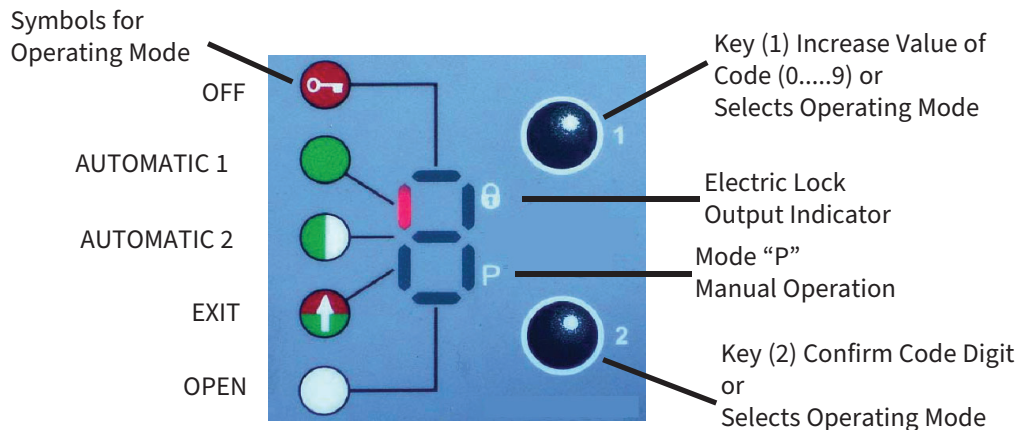

# Start-Up

## Enter Code "111" to Gain Access to Programming:

(Code "111" needs to be performed after 10 minutes of programming inactivity)

Press both keys simultaneously until	<b>C</b>	Is displayed.
Press Key 2 and	<b>0</b>	Is displayed.
Press Key 1 until	<b>1</b>	Is displayed and press Key 2 to confirm.
	<b>0</b>	Is displayed.
Press Key 1 until	<b>1</b>	Is displayed and press Key 2 to confirm.
	<b>0</b>	Is displayed.
Press Key 1 until	<b>1</b>	Is displayed and press Key 2 to confirm.
	<b>P</b>	Is displayed, Operator is ready to be programmed

Note: The next several steps will walk you the calibration of the door.

5. Enter the code: P030

## To Enter Code "030" to Calibrate Door Limits:

Press both keys simultaneously until	<b>P</b>	Is displayed.
Press Key 2 and	<b>0</b>	Is displayed and press Key 2 to confirm "0".
Press Key 1 until	<b>3</b>	Is displayed and press Key 2 to confirm.
A slow flashing	<b>0</b>	Is displayed and press Key 2 to confirm.
	<b>P</b>	is displayed, Operator is ready for additional programming

6. Enter the code: P036

## To Enter Code "036" to Calibrate Door Panel Weight:

Press both keys simultaneously until	<b>P</b>	Is displayed.
Press Key 2 and	<b>0</b>	Is displayed and press Key 2 to confirm "0".
Press Key 1 until	<b>3</b>	Is displayed and press Key 2 to confirm.
A slow flashing	<b>0</b>	Is displayed.
Press Key 1 until	<b>6</b>	is displayed, and press key 2 to confirm.

Once a beep is heard, and AP is displayed, it is necessary to push the small blue SW2 button on the far right of the controller. This will open the door and it will time out and close. Continue to open the door using the blue SW2 button after each close cycle.

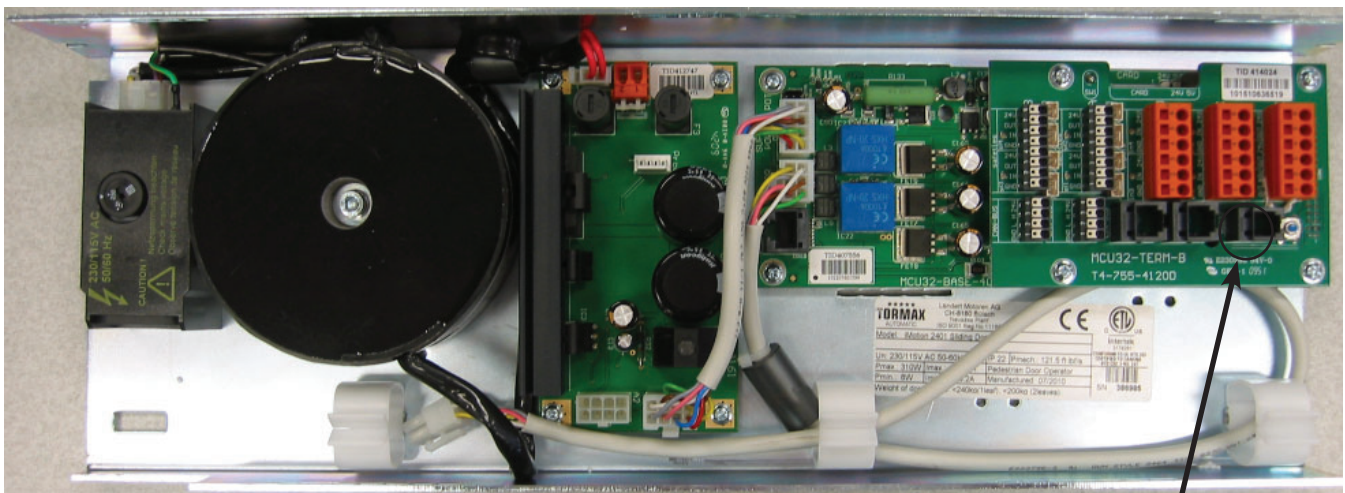

\*\* NOTE \*\* The door may take up to 14 cycles before calibration is complete. During the calibration process, the function pad will display:

SW2 Button

**After the Code "036" is entered:**

Activate door with BLUE switch SW2 on control board	<b>H63</b>	Is displayed when door is opening.
	<b>H62</b>	Is displayed when door is closing.
	<b>H65</b>	Is displayed when door is closed.
When door closes, Press BLUE SW2 to activate door until	<b>H65</b>	is no longer displayed and controller beeps (14 cycles)

7. Once the calibration is complete, a beep will be heard and the function pad will return to a single red line. Select **AUTOMATIC 1 MODE**.

**Setting the Operating Modes:**

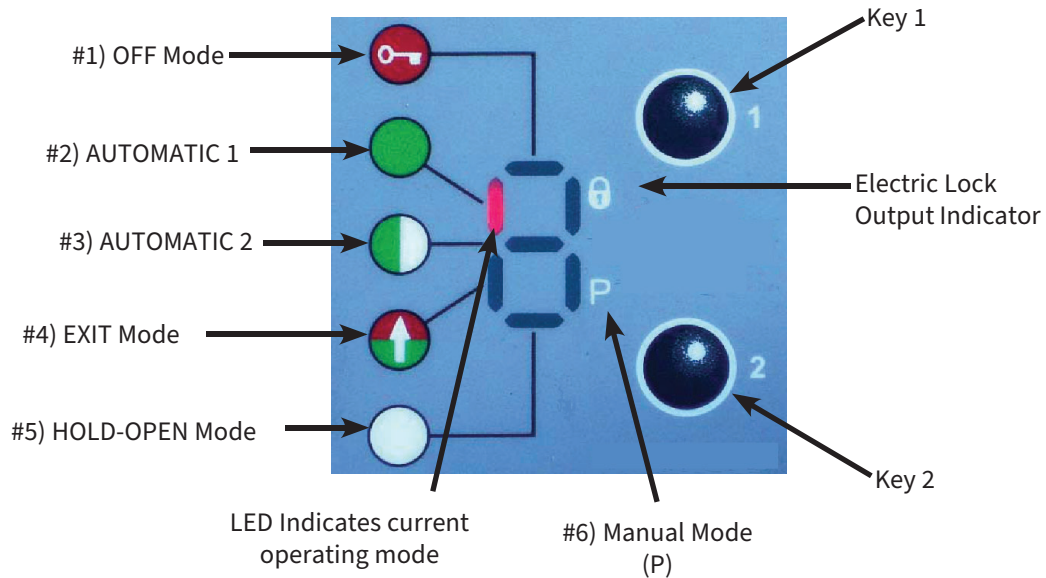

- a. **OFF Mode:**  
The interior and exterior activators are inhibited after the door has reached the fully closed position. If an electric lock has been installed, it will be activated. The operator will cycle if a signal is sent to the key switch input
- b. **Automatic 1 Mode:**  
Typical setting for normal operation. This setting allows interior and exterior activators, key switch, and safety devices to operate door.
- c. **Automatic 2 Mode: (Reduced Opening)**  
Allows the door to open with a reduced opening width. If necessary, hold open time can be adjusted different from Automatic 1 Mode.
- d. **EXIT Mode:**  
Allows interior activator and key switch inputs to operate the door system. Exterior activator is inhibited while door is closed but becomes active when the door is operated by the interior activator or key switch inputs.
- e. **HOLD-OPEN Mode:**  
Holds the door system open.
- f. **MANUAL OPERATION (P) Mode:**  
Allows the door to be used manually without the use of sensors.

8. Supply an activating signal. The door will open faster and close at a slower speed. It will operate at default speeds set during the calibration run above. The microprocessor senses panel weight and calculates braking distances.
9. Install all activation devices & test door.
10. If the customer desires to modify the door operating parameters such as opening or closing speed, hold open time or reduced door opening width, see the programming codes.
11. Supply another activating signal to test reversing photoeyes by blocking the light beam while door is closing. The door should open and remain open until the obstruction has been removed, the door will automatically close. Cycle the door several times to verify correct operation by all activators, safety devices and proper seal of the gasket. Make any necessary adjustments.
12. Test the automatic reversing by blocking the door during closing. Cycle the door open and closed again. Supply another input and block the door during opening.
13. Install the shroud. Shrouds over 10' long will be made in 2 pieces.
14. Mount 4 brackets on top of header in locations shown with self drilling and tapping screws.
15. Snap function control panel into steel mounting/splice bracket.
16. Loop excess cable from function control panel and secure with tie wraps.

## Activator Signals

**Inputs C1 & C2 – OPEN WITH TIME DELAY CLOSE ACTIVATOR:** This input is connected to a normally open pushbutton or other momentary contact that when activated, will open the door. As long as the contact is closed the door will remain open. When the contact is reopened, then, after a set time, the door will close automatically.

**Inputs C1 & C2 – Optional - with Key Code 822, OPEN WITHOUT TIME DELAY CLOSE:** This input is connected to a normally open pushbutton or other momentary contact that when activated, will open the door. The door will remain open until it receives another contact closure, at which time the door will close.

**Inputs C1 & C3, C4 & C6, D1 & D3, D4 & D6 - 24VDC POWER – ACTIVATORS:** This power supply can be used for optional activators and locks.

**Inputs B5 & B6 – EMERGENCY STOP SWITCH:** This input requires a normally closed contact, that when opened during door operation will immediately cause the door to stop by automatic braking, after which the door panel can be moved freely. The door will not operate until the contact is re-made.

**Inputs D4 & D5 – DOOR INHIBIT:** This optional input is connected to a normally closed switch. When this signal is broken, the door will not open. This input can be used to interlock this door with other doors, conveyors, security systems, etc.

Other Inputs are available for various functions, to be programmed via the Keypad

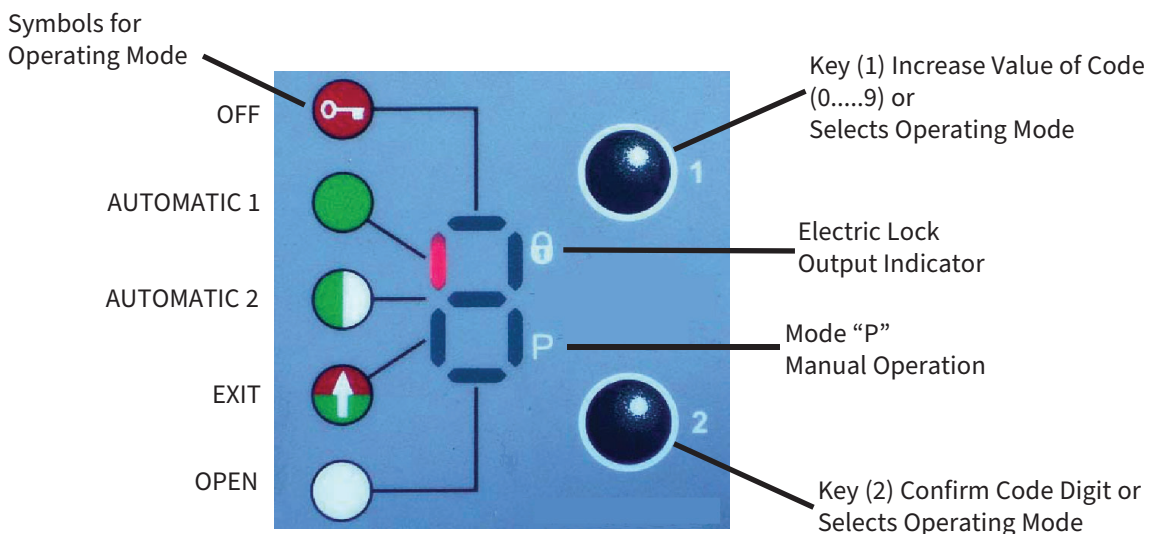

# Programming Parameter Codes

## NOTE

- 1) **Do NOT** change parameters #01 thru #07 without consulting factory.
- 2) The most common parameter changes are highlighted below.

\* = Default Value

Code	Function	Note															
01 1	iMotion 2301 drive system																
01 2	iMotion 2401 drive system																
02 1	Automatic configuration Bi - Part, Right Handed	Performs codes 030-037, 07x															
02 2	Automatic configuration Left Handed	Performs codes 030-037, 07x															
03 0	--Calibration run for full open and full close position																
03 1	--NO, NC or monitoring detection of SF1 - SF4 or (SW2: for 3 beeps)																
03 2	--Detecting and storing MCU Lock Module 1	Only with code 572. Check coding on module															
03 3	--Detecting and storing of MCU Battery Module																
03 4	--Detecting and storing of MCU I/O- Module 1+2	Check coding on module															
03 5	--Detecting and storing of MCU Power supply Module																
03 6	--Detecting and storing of Door mass	Display H65															
03 7	--Detecting 2nd FCP	Check coding on module															
03 8	-NO or NC signal detection on IN1 - IN4																
03 9	I/O Module 1: Detecting and storing of "in 1-4" (NO, NC)																
04 0	Reset	Starts program with calibration run															
04 2	Firmware version	Example: r06_00 = V06.00															
04 3	Number of cycles	Example: c10_302 = 10'302 cycles (max. 99'999'999)															
04 4	Number of operating hours	Example: h4_002 = 4002 hours (max.99'999'999)															
05 5	Delete fault protocol																
04 6	Address of control unit for network	Example: A1 = address no. 1															
06 0*	Control without FRW	FRW = Equipment for rescue and escape routes															
06 1...8	Functions with FRW																
07 0...9	--Door mass	Automatic detection contained in 021 / 022															
10 0...F	Hold-open time of activator in mode of op. AUTO1																
	0	1	2*	3	4	5	6	7	8	9	A	B	C	D	E	F	code
	0	0.5	1	2	3	5	7.5	10	12.5	15	17.5	20	25	30	45	60	sec.
11 0...F	Hold-open time of activator in mode of op. AUTO2 (Reduced Opening)																
	0	1	2*	3	4	5	6	7	8	9	A	B	C	D	E	F	code
	0	0.5	1	2	3	5	7.5	10	12.5	15	17.5	20	25	30	45	60	sec.
12 0...F	Hold-open time of key switch																
	0	1	2*	3	4	5	6	7	8	9	A	B	C	D	E	F	code
	0	0.5	1	2	3	5	7.5	10	12.5	15	17.5	20	25	30	45	60	sec.
13 0...9	Delay time for Mode OFF to become active																
	0	1	2*	3	4	5	6	7	8	9							code
	1	3	5	7.5	10	15	20	30	45	60							sec.
14 0...9	Bell duration															0 = Duration identical to trigger duration	
	0	1	2	3	4	5	6*	7	8	9							code
	id	0.5	1	2	3	4	5	6	8	10							sec.

# Programming Parameter Codes continued

\* = Default Value

Code	Function										Note
15 0...9	Bell intermission										
	0	1	2	3	4	5	6*	7	8	9	code
	0	0.5	1	2	3	4	5	6	8	10	sec.
16 0...9	Hold open time of safety										
	0	1	2*	3	4	5	6	7	8	9	code
	0	0.5	1	2	3	4	5	6	8	10	sec.
17 0...9	Runtime Battery in mode of op. 2-6										Door opens after switch-off battery
	0	1	2	3*	4	5	6	7	8	9	code
	10s	1	5	10	30	60	120	240	360	480	sec/min.
18 0...9	Runtime Battery in mode of op. OFF										
	0*	1	2	3	4	5	6	7	8	9	code
	10s	1	5	10	30	60	120	240	360	480	sec/min.
20 1...9	Opening Speed										
	0	1	2	3	4	5	6*	7	8	9	Code
	3.93	7.87	11.8	15.75	19.69	23.62	27.56	31.5	35.43	39.37	inch/s
21 0...9	Closing Speed										
	0	1	2	3	4*	5	6	7	8	9	code
	31.5	6.3	9.45	12.6	15.75	18.9	22.05	25.2	28.35	31.5	inch/s
22 0...9	Close check speed										
	0*	1	2	3	4	5	6	7	8	9	code
	.56	.62	.68	.81	1	1.18	1.43	1.68	2	2.36	inch/s
26 0...9 2*	Braking distance opening										9 = max
28 0...9 4*	Braking distance closing										9 = max

30 0...9	Motor force opening										Net force on door edge
	0*	1	2	3	4	5	6	7	8	9	Code
	.56	.62	.68	.81	1	1.18	1.43	1.68	2	2.36	%
31 0...9	Motor force closing										Net force on door edge
	0	1	2	3	4	5*	6	7	8	9	Code
	5	11	22	33	44	55	66	77	88	100	%
33 0...9	Force closed position										Net force on door edge > reduce if H73 after 10s!
	0	1	2	3	4	5*	6	7	8	9	Code
	10	20	30	40	50	60	70	80	90	100	N
35 0...9 5*	Reversing sensitivity opening										9 = max
36 0...9 5*	Reversing sensitivity closing										9 = max
39 0...9 5*	Travel distance tolerances (60...300%)										
51 0*	Operating mode return to last setting on Function Control Panel										After terminal operating mode
51 1...6	Operating mode return to mode of op. ...										After terminal operating mode
	1	2	3	4	5	6					Code
	OFF	AUT1	AUT2	EXIT	OPEN	MAN.					Mode of Operation
51 7	No operating mode return										After terminal operating mode
55 0*	Locks in operating mode OFF										
55 1	Locks in operating mode OFF, EXIT										
55 2	Locks in operating mode OFF, AUTO 1+2, EXIT										
56 0*	Never unlocks in case of power failure										

**1250 POWER  
INSTALLATION**

# Programming Parameter Codes continued

\* = Default Value

Code	Function	Note
55 1	Locks in operating mode OFF, EXIT	After terminal operating mode
55 2	Locks in operating mode OFF, AUTO 1+2, EXIT	
56 0*	Never unlocks in case of power failure	
56 1	Unlocks in AUTO1, AUTO2, EXIT in case of power failure	
56 2	Unlocks in every operating mode in case of power failure	
57 0	Electric strike: current-free locked	
57 1	Electric strike: current-free unlocked	Only for electric strikes with 100% Duty ratio
57 2*	Lock type "Lock unit 2301/2401" with automatic configuration	
57 3	Electric strike switch-on range 100%, until door is closed	Only for electric strikes with 100% Duty ratio
57 4	Lock type "STARLOCK", with automatic detection	With Lock Module LOCK-200-A
57 5	Lock type "89 TCP", with automatic detection	With Lock Module LOCK-200-A
58 0..9	Delay time to open	Only valid if electric strike has to unlock
	0* 1 2 3 4 5 6 7 8 9	Code
	0 0.2 0.4 0.8 1.2 1.6 2 2.5 3 4	Sec.
59 1..4	Voltage Output (E1 - E2)	** With connection between "pwm" and "24V"
	0 1 2 3 4* 5 6	Code
	6 9 12 15 24 12** 24**	C DC
60 0	in1: Operation mode OFF	Contact NO. NC detect with code 038.
60 1	in1: Operation mode MANUAL / Breakout / Park	Contact NO. NC detect with code 038.
60 2	in1: Operation mode OPEN	Contact NO. NC detect with code 038.
60 3*	in1: Activator inside	Contact NO. NC detect with code 038.
60 4	in1: Activator outside	Contact NO. NC detect with code 038.
60 5	in1: Key switch	Contact NO. NC detect with code 038.
60 6	in1: Emergency open except in OFF	Contact NO. NC detect with code 038.
60 7	in1: Emergency open in all modes of op.	Contact NO. NC detect with code 038.
60 8	in1: Emergency close (with locking)	Contact NO. NC detect with code 038.
60 9	in1: Operation mode EXIT	Contact NO. NC detect with code 038.
61 0..9 4*	in2: Same choice of functions as on "in1"	Contact NO. NC detect with code 038.
62 0..9 5*	in3: Same choice of functions as on "in1"	Contact NO. NC detect with code 038.
63 0..9 0*	in4: Same choice of functions as on "in1"	Contact NO. NC detect with code 038.
64 0	sf1: Safety opening 1 with stop function	Type of connection detect with code 031
64 1	sf1: Safety opening 1 with creeping function	Type of connection detect with code 031
64 2*	sf1: Safety closing 1 with reversing function	Type of connection detect with code 031
64 3	sf1: Safety closing 1 with creeping function	Type of connection detect with code 031
64 4	sf1: Safety swing area	Type of connection detect with code 031
64 5	sf1: Safety stop	Type of connection detect with code 031
64 6	sf1: Emergency opening except in OFF	Type of connection detect with code 031
64 7	sf1: Emergency opening in all modes of op.	Type of connection detect with code 031
64 8	sf1: Emergency closing (with locking)	Type of connection detect with code 031
64 9	sf1: Mode of op. MANUAL / Break out / Park	Type of connection detect with code 031
64 A	sf1: Safety opening 2 with stop function	Type of connection detect with code 031
64 b	sf1: Safety opening 2 with creeping function	Type of connection detect with code 031
64 C	sf1: Safety closing 2 with reverse function	Type of connection detect with code 031
64 d	sf1: Safety closing 2 with creeping function	Type of connection detect with code 031
65 0..d C*	sf2: Same choice of functions as on "sf1"	Type of connection detect with code 031

# Programming Parameter Codes Continued

\* = Default Value

Code	Function	Note
66 0...d 0*	sf3: Same choice of functions as on "sf1"	Type of connection detect with code 031
67 0...d A*	sf4: Same choice of functions as on "sf1"	Type of connection detect with code 031
68 0	out1: Message "door closed"	
68 1	out1: Message "door closed and locked"	
68 2	out1: Message "door open"	
68 3	out1: Message "General error"	
68 4*	out1: Bell	
68 5	out1: Message "Mode of operation OFF"	
68 7	out1: Battery in service	
68 9	out1: Message "door opening or open"	out2: Same choice of functions as on "out1"
69 0...9 0*	out2: Same choice of functions as on "out1"	
70 0*	I/O Module 1: in1: No function	
70 1	I/O Module 1: in1: Operation mode OFF	Contact NO. NC detect with code 039.
70 2	I/O Module 1: in1: Operation mode AUTOMATIC 1	Contact NO. NC detect with code 039.
70 3	I/O Module 1: in1: Operation mode AUTOMATIC 2	Contact NO. NC detect with code 039.
70 4	I/O Module 1: in1: Operation mode EXIT	Contact NO. NC detect with code 039.
70 5	I/O Module 1: in1: Operation mode OPEN	Contact NO. NC detect with code 039.
70 6	I/O Module 1: in1: Operation mode MANUAL	Contact NO. NC detect with code 039.
70 7	I/O Module 1: in1: Inhibit switch	Contact NO. NC detect with code 039.
71 0...7 0*	I/O Module 1: in2: Same choice of functions as on I/O Module 1: in1	Contact NO. NC detect with code 039.
72 0...7 0*	I/O Module 1: in3: Same choice of functions as on I/O Module 1: in1	Contact NO. NC detect with code 039.
73 0...7 0*	I/O Module 1: in4: Same choice of functions as on I/O Module 1: in1	Contact NO. NC detect with code 039.
74 0*	I/O Module 1: out1: No function	
74 1	I/O Module 1: out1: Mode of op. OFF	
74 2	I/O Module 1: out1: Mode of op. AUTOMATIC 1	
74 3	I/O Module 1: out1: Mode of op. AUTOMATIC 2	
74 4	I/O Module 1: out1: Mode of op. EXIT	
74 5	I/O Module 1: out1: Mode of op. OPEN	
74 6	I/O Module 1: out1: Mode of op. MANUAL	
74 7	I/O Module 1: out1: "Door opens"	
74 8	I/O Module 1: out1: "door is opening or open"	
74 9	I/O Module 1: out1: "Door closes"	
75 0...9 0*	I/O Module 1: out2: Same choice of functions as on I/O Module 1: out1	
76 0...9 0*	I/O Module 1: out3: Same choice of functions as on I/O Module 1: out1	
77 0...9 0*	I/O Module 1: out4: Same choice of functions as on I/O Module 1: out1	
78 0	User Interface 1: in1: No function	
78 1*	User Interface 1: in1: Panel lock	Contact NO
78 2	Function Control Panel: in1: Mode of op. OFF	Contact NO
78 3	Function Control Panel: in1: Mode of op. AUTOMATIC 2	Contact NO
78 4	Function Control Panel: in1: Mode of op. EXIT	Contact NO
78 5	Function Control Panel: in1: Mode of op. OPEN	Contact NO
78 6	Function Control Panel: in1: Mode of op. MANUAL / Breakout / Park	Contact NO
78 7	Function Control Panel: in1: Emergency closing	Contact NO
78 8	Function Control Panel: in1: Emergency opening in all op. modes	Contact NO
78 9	Function Control Panel: in1: Key switch	

\* = Default Value

Codes	Function	Note
79 0...9 0*	Function Control Panel: in 2: Same choice as on FCP : in1	
80 0*	Bell trigger: Safety closing 1	
80 1	Bell trigger: Safety closing 2	
80 2	Bell trigger: Activator inside	
80 3	Bell trigger: Activator outside	
80 4	Bell trigger: Key switch	
82 0*	No step by step control	Push Open Time to Close see Params 10.1 to 10.9
82 1	Step by step control only for key switch	
82 2	Step by step control only for activator inside and outside	Push Open / Push Close
82 3	Step by step control for activator inside, outside and key switch	
85 0*	No airlock function	

## Inspection

### MANUAL & POWER

- CHECK THE CONDITION OF THE MAIN ROLLER WHEELS.** Replace if the flange is  $\frac{1}{16}$ " thick or less, and if the roller has excessive foreign debris on the working surface (Figure 33).
- CHECK GASKETS FOR PROPER SEALING.** Look for gasket compression along the entire door perimeter.
- CHECK MAIN DRIVE BELT FOR TENSION.** Allow a maximum deflection per chart (Figure 34) on one leg of the belt. Apply weight to belt & check deflection. If the tension is too loose, loosen and adjust the idler pulley bracket to maintain the desired tension. Once the proper tension is set, re-tighten the idler pulley bracket.

### POWER

- CHECK OPERATOR MOUNTING BOLTS AND IDLER PULLEY BRACKET BOLTS FOR PROPER TIGHTNESS.**  
During the initial run in period these items may loosen.

## Preventative

### 1240 Manual/1250 Power

#### DAILY

- Check for proper operation and inspect all safety devices. These include all reversing photoeyes and the electronic reversing of the operator while opening or closing.

#### MONTHLY (Manual & Power)

- Check roller truck and panel mounting bolts.
- Check for a tight door seal. Make adjustments as shown in Section 2.
- Check gaskets for wear. Replace if torn or worn.
- Check header mounting bolts and tighten where necessary.
- Check drive belt tension (Figure 34).

#### MONTHLY (Power)

- Check operator mounting bolts.
- Check idler pulley bracket mounting bolts.
- Check all wiring for loose or sagging wires monthly or every 100,000 cycles, whichever comes first.

#### ANNUALLY (Power)

- Check drive belt for wear. (sides and teeth)
- Check all wiring for loose or sagging wires.
- Check photoeye operation.

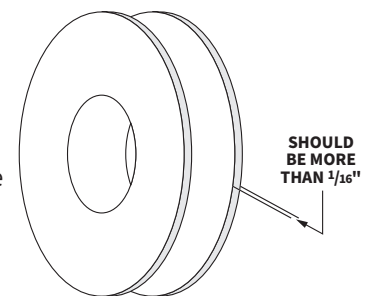

Figure 33: Roller Wheel Inspection

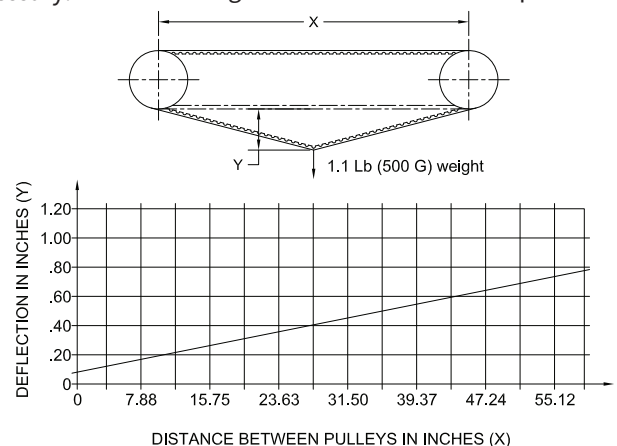

Figure 34: Drive Belt Tension Chart

# Troubleshooting

	Problem	Probable Cause	Corrective Measures
Manual	A. Door panel difficult to close or open	1. Gasket too tight. 2. Gasket sticks.	1. Readjust panel for minimum gasket pressure. 2. Apply small amount of lubricant to the header surface only (Armor All or Automotive Wax).
	A. Door will not open	1. No power 2. Loose or disconnected wire. 3. Defective actuator	1. Check power switches, fuses & connections. Verify 115 VAC voltage at power outlet. 2. Check wiring and connection. 3. Check wiring and actuator with ohmmeter.
Power	B. Inconsistent starting, and stopping & reverse	1. Loose or poor connection	1. Check connections in control circuit and in all connections on the photoeyes.
	C. Door opens but will not close	1. Photoeye malfunction 2. Activator	1. Realign photoeye, inspect wiring and amplifier, replace if necessary. 2. Inspect wiring, replace if necessary.
	D. Door closes and opens immediately	1. Photoeyes signaling to reopen	1. Check for seals blocking photoeye, or obstruction in doorway.
	E. Drive belt "slaps" bottom side of rail	1. Belt is loose	1. Re-tension drive belt.

## Fault Diagnosis

"E" = Error, "H" = Hint

### NOTE

**Note** the most common error & hint codes are highlighted below.

General Fault Table

* No.	Fault	Reaction System	Reset
E00	Firmware incompatible to MCU version /D	Safety operating mode or only display	Reset, new version MCU32-BASE
E0x	Internal test negative	Safety operating mode or only display	Reset
E11	MCU Lock 1, wrong position	Door cannot open	Automatically if OK
E20	LIN to Monit. Battery mod. MBAT interrupted	-	Reset
E21	LIN to FCP 1 interrupted	Last mode of operation remains	Automatically if OK
E22	LIN to FCP 2 interrupted	Last mode of operation remains	Automatically if OK
E23	LIN to s I/O-Module 1 INOU interrupted	Programmed function will be inactive	Automatically if OK
E24	LIN to s I/O-Module 2 INOU interrupted	Programmed function will be inactive	Automatically if OK
E25	LIN to Lock Unit 1 LOCU interrupted	Last status remains	Automatically if OK
E26	LIN to Lock Unit 2 LOCU- interrupted	Last status remains	Automatically if OK
E29	LIN to Power Supply PSUP-40-36 interrupted	Last status remains	Automatically if OK
E30	Safety clos. creep 2 >1min. Active, test neg.	According safety function	Automatically if OK
E31	Safety open 1 >1min. Active, test neg.	According safety function	Automatically if OK
E32	Safety op. creep 1 >1min. Active, test neg.	According safety function	Automatically if OK
E33	Safety closing 1 >1min. Active, test neg.	According safety function	Automatically if OK
E34	Safety clos. creep 1 >1min. Active, test neg.	According safety function	Automatically if OK
E35	Safety swing area >1min. Active, test neg.	According safety function	Automatically if OK
E36	Safety stop >1min. Active, test neg.	According safety function	Automatically if OK
E37	Safety open 2 >1min. Active, test neg.	According safety function	Automatically if OK
E38	Safety op. creep 2 >1min. Active, test neg.	According safety function	Automatically if OK
E39	Safety closing 2 >1min. Active, test neg.	According safety function	Automatically if OK
E41	Activator inside > 1min. Active	Door remains open	Automatically if OK
E42	Activator outside > 1min. Active	Door remains open	Automatically if OK
E43	Key switch > 1min. active	Door remains open	Automatically if OK
E46	Emergency open >10min. active	Door remains open	Automatically if OK
E47	Emergency close >10min. active	Door closes and remains closed	Automatically if OK
E48	Wake up or Push button SW2 > 1min. active	Door remains open	Automatically if OK
E49	Inhibit switch > 1min. active	Door stand still	Automatically if OK
E51	Encoder not working	Safety operating mode	Automatic Reset
E53	Calibration run different from stored value	Safety operating mode	Reset with code 030
E54	Door traveling farther than stored value	Safety operating mode	Reset >automatic configuration
E55	Position different by > 5/16", tooth belt jumping	Only display, auto-correction stops	Automatically if OK / Reset

## Fault Diagnosis Continued

*No.	Fault	Reaction System	Reset
E61	Voltage 40V outside of admissible range	Safety operating mode	Automatically if OK
E62	Power supply 24V (Limit U/I)	Safety operating mode	Automatically if OK
E63	Current in power supply 40V too high	Safety operating mode	Automatically if OK
E64	Motor temp. > 90 ° C, cable interrupted	Safety operating mode	Automatically after cooling down
E65	Control end stage > 100 ° C	Safety operating mode	Automatically after cooling down
E66	Motor control faulty in MCU32-BASE	Safety operating mode	Reset
E67	Motor current too high in long-term	Normal operation	Automatically if OK
E72	Battery Unit MBTU: Charge < 15%	-	Automatically if OK
E73	Battery Module MBAT or ACCU faulty	-	Disconnect power supply
E8x	Memory or processor test negative	Safety operating mode	Reset
H11	Operator type not defined	Safety operating mode	Program operator type
H14	Automatic configuration not executed	Safety operating mode	Program 021 or 022
H61	Calibration run in opening direction	Searches open position	At the end of movement
H62	Calibration run in closing direction	Searches closed position	At the end of movement
H63	Reference run opening	Measures reference run length	At the end of movement
H64	Reference run closing	Searches closed position	At the end of movement
H65	Learn mode (Weight detection)	Normal operation	After 3-12 opening cycles
H71	Battery mode	Door moves slowly	Power supply return
H73	Motor current in closed position too high	Normal operation	Reset, reduce 33x
H91	Obstacle detection at opening	Door reverses	Automatically, Display 20s.
H92	Obstacle detected at closing	Door reverses	Automatically, Display 20s.
H93	Permanent obstacle at opening	Reset after 5 reversings	Automatically, Display 20s.
H94	Permanent obstacle at closing	Reset after 5 reversings	Automatically, Display 20s.

**Electrical Fault Table, Page 1**

System Behavior	No.	Cause	Remedy/ Rectification
The door stops when opening.	H91	Electronic obstacle recognition on opening by a person, wind pressure, ventilation or dirt in the floor guide.	Remove the obstruction. Clean the floor guide in operating mode P.
Door reverses when closing.	H92	Electronic obstacle recognition on closing by a person, wind pressure, ventilation or dirt in the floor guide.	Remove the obstruction. Clean the floor guide in operating mode P.
The door stops repeatedly when opening.	H93	Electronic obstacle recognition on opening in the same position by stationary obstacle.	Remove the obstruction. Clean the floor guide in operating mode P.
The door stops repeatedly when closing.	H94	Electronic obstacle recognition on closing in the same position by stationary obstacle.	Remove the obstruction. Clean the floor guide in operating mode P.
Search run notified.	H61 H62	Search run of the door after a reset or after power recovery.	Allow the search run to travel its full course.
Door operates at a reduced speed.	H71	Battery operation	Wait for power recovery Switch on mains supply.
Door remains closed.	-	Operating mode such as OFF, EXIT or P.	Select operating mode AUTOMATIC 1.
Door remains open.	-	Operating mode such as OPEN or P.	Select operating mode AUTOMATIC 1.
The door does not lock in OFF.	E11	Lock is jammed or defective.	Push the door leaves for a few seconds against the closed position in operating mode OFF when the door is closed. Have the system repaired by experts.
The door does not open after changing from OFF to AUTOMATIC. The lock makes switching noises from time to time.	E11	Lock is jammed or defective.	Push the door leaves for a few seconds against the closed position in operating mode AUTOMATIC 1. Have the system repaired by experts.

## Fault Diagnosis Continued

System Behavior	No.	Cause	Remedy/Rectification
The door does not open in OFF when the key switch is used. The lock makes switching noises.	E11	Lock is jammed or defective..	Switch on with the key switch and then push the door leaves briefly against the closed position. Have the system repaired by experts.
Dependent on configuration.	E2 ...	Error in bus system	Have the system repaired by experts.
The door closes slowly.	E30 E34	The safety facility in the closing direction is permanently active (>1 minute) or defective.	Remove objects from within the range of the sensor(s). Otherwise have the system repaired by an expert.
Door remains closed.	E31 E37	The safety facility in the opening direction is permanently active (>1 minute) or defective.	Remove objects from within the range of the sensor(s). Otherwise have the system repaired by an expert.
The door opens slowly.	E32 E38	The safety facility in the opening direction is permanently active (>1 minute) or defective.	Remove objects from within the range of the sensor(s). Otherwise have the system repaired by an expert.
The door remains open.	E33 E39	The safety facility in the closing direction is permanently active (>1 minute) or defective.	Remove objects from within the range of the sensor(s). Otherwise have the system repaired by an expert.
The door remains open.	E41 E42 E43	Activator inside is active > 1 min. Activator outside is active > 1 min. Key switch is active > 1 min.	Get sensor adjusted by a professional. Reset the key switch.
Door remains open.	E46	Emergency opening monitoring > 10 mins. active	Have the system repaired by experts.
The door stands still.	E51	Encoder defective.	Have the system repaired by experts.
The door stands still.	E53 E54 E55 E56	Anomaly in the travel distance. Solid obstruction in the movement area.	Remove firm obstacle in the traveling range of the door. Perform a software-reset. Have the system repaired by experts.
The door stands still.	E61 E62 E63	Power supply is overloaded or voltage too low.	Get the power supply and connections checked by a professional.
The door stands still.	E64 E65	Drive/control system is overheated.	Wait for the automatic reset after the door/control system has cooled. Protect from direct sunlight.
The door stands still.	E66	Motor control defective.	Have the system repaired by experts.
Normal operation	E67	Drive heavily loaded.	Wait for the automatic reset Otherwise have the system repaired by an expert.
Door remains open or normal operation.	E72	Battery charge < 15 %	Wait until battery is sufficiently charged
Door remains open or normal operation.	E73	Battery unit defective	Have the system repaired by experts.
The door stands still.	E8..	Control system shut down for safety reasons.	Perform a software-reset. Have the system repaired by experts.
The door collides with people.	-	Safety device or setting inadequate.	Shut down the system.

## Instructions for Ordering

This parts manual is intended to assist in the correct identification of the more commonly replaced parts. The manual will also help identify obsolete parts, part design changes and current production parts. For more specific parts information, please contact an authorized representative or consult the factory's customer service or engineering departments. Asi doors reserves the right to discontinue any part and make design changes without notice.

### General Instructions for Ordering Door Parts

Accurate information is always necessary to serve you correctly and promptly. Several steps should be followed to determine exactly the parts that are needed.

Refer to the information tag on your door and record the:

1. Door model number
2. Job number
3. Door number
4. Manufacturing date.

Use part numbers referenced in this manual.

If the item is not found in the manual, the product code on the back of the item is helpful.

If your door has no information label, the approximate purchase date is helpful.

Call

**1-800-558-7068**

or visit

**[asidoors.com/parts](https://asidoors.com/parts)**

to order parts

# Door Identification

Determining the Job Number, Model and Year of Manufacture of your door is necessary to provide quick and accurate parts identification. The following is a description of labels and their locations.

When ordering parts, specify Job Number, Door Number and Manufacture Date

Product Labels:

Manual Doors

<b>ASI Doors, Inc.</b>		
MILWAUKEE	WISCONSIN	MADE IN USA
DOOR MODEL <input style="width: 100%; height: 15px;" type="text"/>	JOB NUMBER <input style="width: 100%; height: 15px;" type="text"/>	DOOR NUMBER <input style="width: 100%; height: 15px;" type="text"/>
MFG. DATE <input style="width: 100%; height: 15px;" type="text"/>	INSPECTED BY <input style="width: 100%; height: 15px;" type="text"/>	

Power Doors

<b>ASI Doors, Inc.</b>			
MILWAUKEE	WISCONSIN	MADE IN USA	
DOOR MODEL <input style="width: 100%; height: 15px;" type="text"/>	JOB NUMBER <input style="width: 100%; height: 15px;" type="text"/>	DOOR NUMBER <input style="width: 100%; height: 15px;" type="text"/>	
MFG. DATE <input style="width: 100%; height: 15px;" type="text"/>	INSPECTED BY <input style="width: 100%; height: 15px;" type="text"/>		
OPERATOR TYPE <input style="width: 100%; height: 15px;" type="text"/>	MODEL # <input style="width: 100%; height: 15px;" type="text"/>	WIRING DIAGRAM <input style="width: 100%; height: 15px;" type="text"/>	
HORSEPOWER <input style="width: 100%; height: 15px;" type="text"/>	VOLTAGE/PHASE <input style="width: 100%; height: 15px;" type="text"/>	HZ <input style="width: 100%; height: 15px;" type="text"/>	AMPERAGE <input style="width: 100%; height: 15px;" type="text"/>

# ID Tag Location

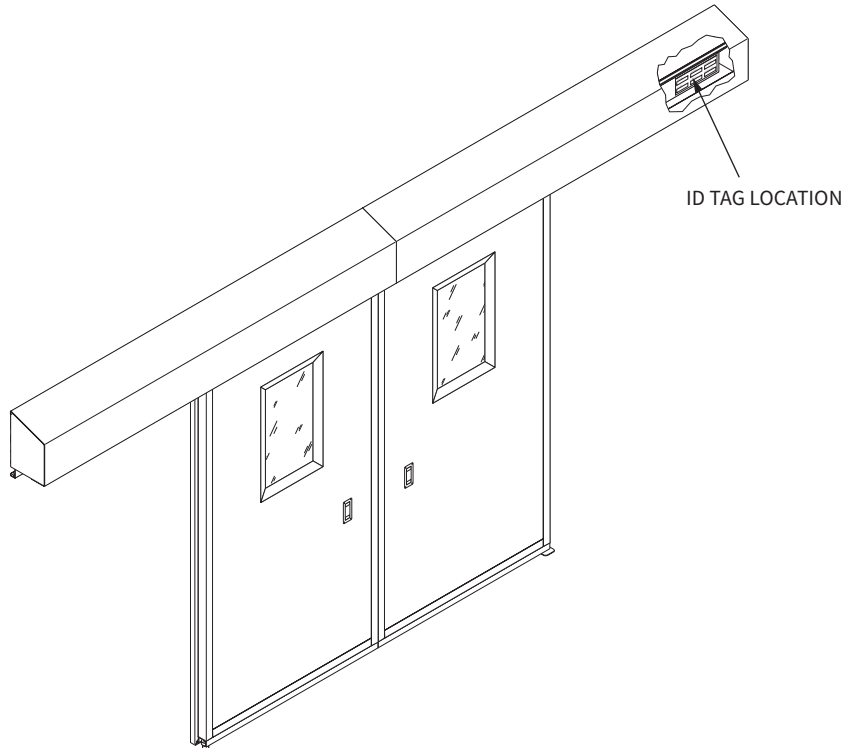

# Door Assembly

When ordering parts, specify  
Job Number, Door Number and  
Manufacture Date

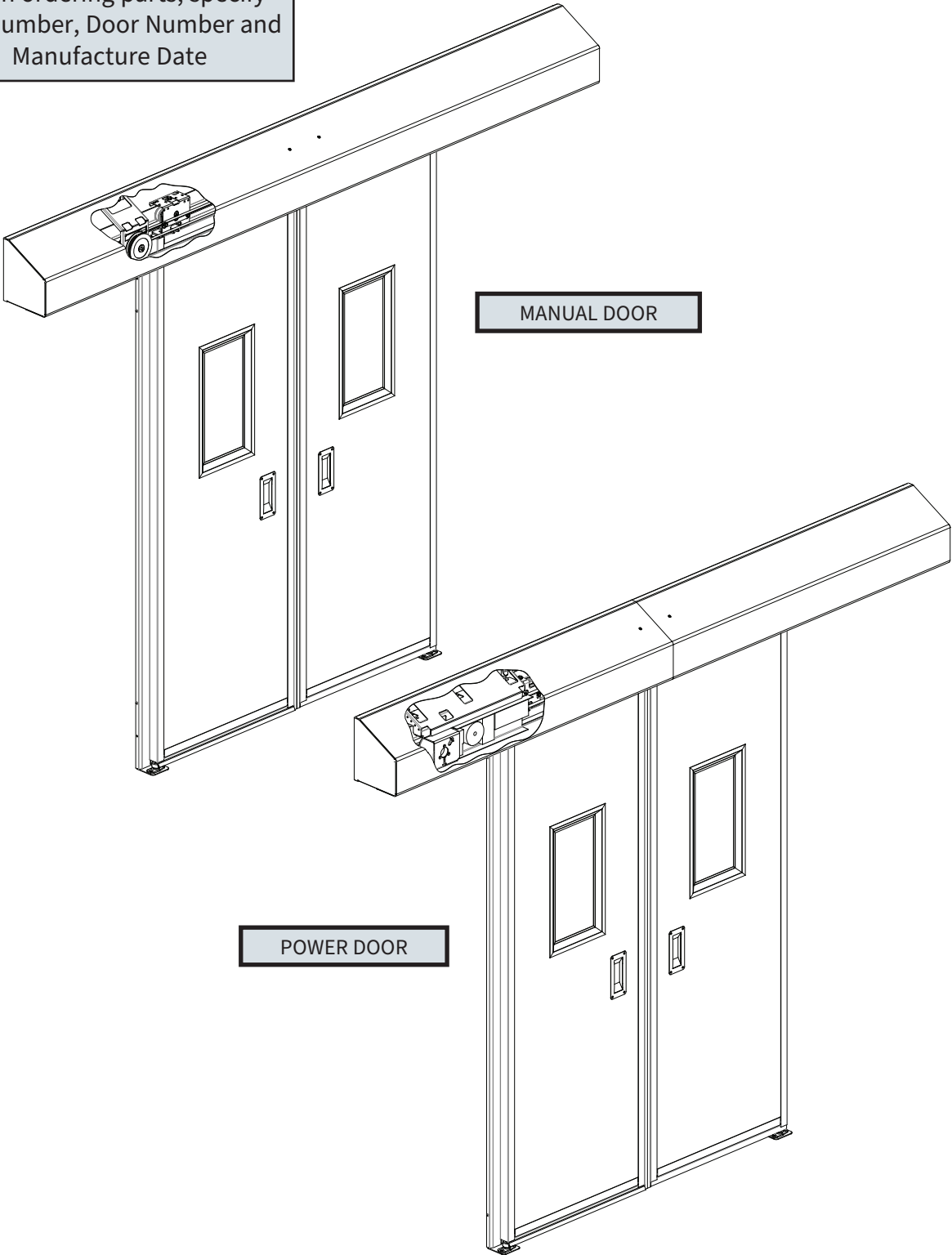

POWER DOOR

MANUAL DOOR

NOTE: Subsequent pages  
show detailed assemblies  
with parts lists.

# Operators

**24B0442NN, Drive & Controller, 2301**

**24B0443NN, Drive & Controller, 2401**

When ordering parts, specify  
Job Number, Door Number  
and Manufacture Date

QTY	DESCRIPTION	PART #	ITEM #
	1 OPERATOR, EXCEL, TORMAX 2301	-	-
1	OPERATOR, EXCEL, TORMAX 2401	-	-
-	1 DRIVE SYSTEM, MOTOR AND CONTROLLER, TORMAX 2301	30D0036	1
1	- DRIVE SYSTEM, MOTOR AND CONTROLLER, TORMAX 2401	30D0037	1
1	1 IDLER BRACKET, PULLEY, EXCEL	13B1181UB	2
-	1 DRIVE BELT, TORMAX TEP OPERATOR	50A120	3
1	- DRIVE BELT, TORMAX TXP OPERATOR	50A132	3
1	1 ASM, BRKT, TOUCH PAD, 2301/2401 (Includes 23A0363)	24B0492NN	4
1	1 TOUCH PAD, CONTROLLER, 2301/2401	23A0363	5
1	1 CABLE, LIN BUS, 2301/2401, 10 FT	23A0371NN	6
4	4 SCREW, 1/4-20 X .375 BH	41A699	7
1	1 NUT, 1/4-28 HEX, SS	41A796	8
1	1 SCREW, 1/4-28 X 2.500, SHCS , FT, SS	41A795	9

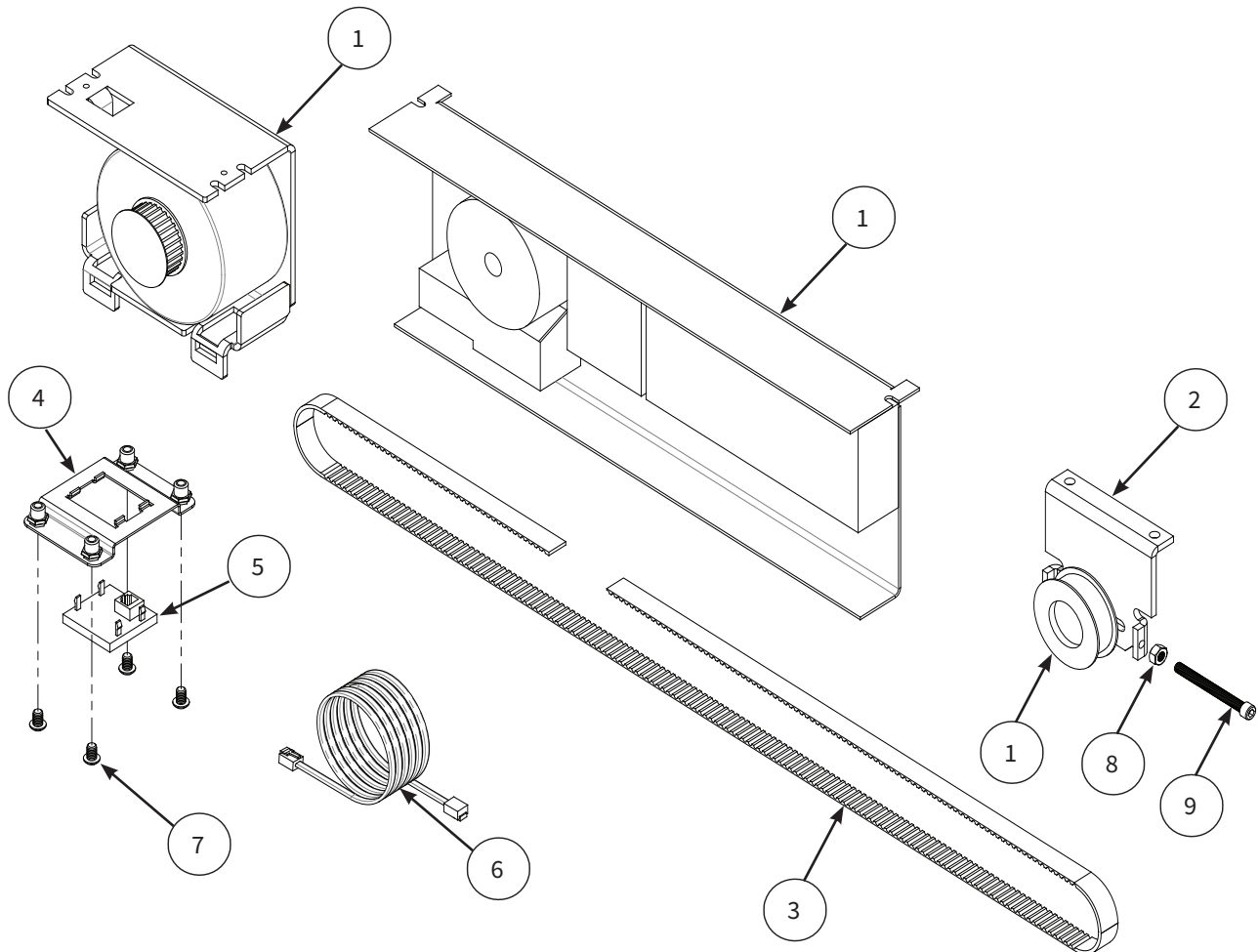

# Header Assembly

## 81D445, Manual, Bi-Part

F4	F3	F2	F1	DESCRIPTION	PART #	ITEM #
-	-	-	1	HEADER ASM, MANUAL BI-PART, 1270, STD, WIC <= 60	81D44F1	-
-	-	1	-	HEADER ASM, MANUAL BI-PART, 1270, AES, WIC <= 60	81D44F2	-
-	1	-	-	HEADER ASM, MANUAL BI-PART, 1270, STD, WIC > 60	81D44F3	-
1	-	-	-	HEADER ASM, MANUAL BI-PART, 1270, AES, WIC > 60	81D44F4	-
-	-	-	1	WELDMT, 1 PC HEADER, STD, MAN, BI-PART, WIC <= 60	28B220UF	1
-	-	1	-	WELDMT, 1 PC HEADER, AES, MAN, BI-PART, WIC <= 60	28B235UF	1
-	1	-	-	WELDMT, HEADER, STD, BI-PART, MAN, WIC > 60	28B193UF	1
1	-	-	-	WELDMT, HEADER, AES, BI-PART, MAN, WIC > 60	28B236UF	1
1	1	1	1	TROLLEY ASSEMBLY, RH, LEAD EDGE	24B198	2
2	2	2	2	TROLLEY ASSEMBLY, TRAILING EDGE	24B199	3
1	1	1	1	TROLLEY ASSEMBLY, LH, LEAD EDGE, BI-PART	24B208	4
1	1	1	1	WLDMT, MTG, CABLE/IDLER, MANUAL EXCEL	28B0272NN20	5
1	1	1	1	WLDMT, MTG, IDLER, MANUAL EXCEL	28B0273NN20	6
2	2	2	2	IDLER BRACKET, PULLEY, EXCEL	13B1181UB	7
1	1	1	1	END STOP, RIGHT HAND, EXCEL	24B224	8
1	1	1	1	END STOP, LEFT HAND ASSY, EXCEL	24B223	9
1	1	1	1	DETENT BRKT, HEADER, MANUAL, ALL (SELF-CLOSER OPTION)	13B1029	10
1	1	1	1	BRKT, DETENT/STOP, MAN EXCEL DOORS (SELF-CLOSER OPTION)	13B1807NN20	11
1	1	1	1	REEL, CABLE (SELF-CLOSER OPTION)	16A042	12
1	1	1	1	CABLE RETURN BRACKET (SELF-CLOSER OPTION)	13B1201UB	13
2	2	2	2	IDLER PULLER, TORMAX TEP	24B211	14
1	1	1	1	DRIVE BELT, TORMAX TEP OPERATOR, BI-PART	50A120-2	15
9	9	9	9	INSERT, HEX, 3/8-16, GRIP RANGE .027-.150	41A788	16
2	2	2	2	INSERT, HEX, 1/4-20, GRIP RANGE .027-.165	41A784	17
4	4	4	4	SCREW, 3/8 X 3/8 SHSS SS	41A670	18
4	4	4	4	NUT, 5/16 WHIZLOCK, SS	41A712	19
6	6	6	6	SCREW, 3/8 X 1.00 HEX HEAD, WHIZLOCK, SS	41A793	20
4	4	4	4	SCREW, 1/4-20 x .625, HHMS, SS	41A303	21
4	4	4	4	NYLON INSERT LOCKNUT, 1/4-20 UNC	41A639	22
1	1	1	1	SPRING PLUNGER, MANUAL DOORS (SELF-CLOSER OPTION)	49B007	23
1	1	1	1	PUSH NUT, .500" I.D. (SELF-CLOSER OPTION)	41A865	24
4	4	4	4	WASHER, FLAT, 1/2, S/S (SELF-CLOSER OPTION)	41A516	25
1	1	1	1	PIN, COTTER, .125 X 1.00, ZN (SELF-CLOSER OPTION)	41A399	26
1	1	1	1	GROMMET, .875 ID	11A086	27
A/R	A/R	A/R	A/R	OPTION, LOCK, PIN-BOLT, 1260/1270, BI-PART, MAN, NO BOLT LOCK	55B0110F1	28
A/R	A/R	A/R	A/R	OPTION, LOCK, PIN-BOLT, 1260/1270, BI-PART, MAN, BOLT LOCK	55B0110F2	28
2	2	2	2	BELT CLAMP, TROLLEY, BI-PART / SINGLE SLIDE	13B1063	29
2	2	2	2	BELT LOCK, TROLLEY, BI-PART / SINGLE	14B148	30
4	4	4	4	1/4-20 X 1.000 BUTTON-HEAD SCREW	41A757	31
4	4	4	4	WASHER, LOCK, 1/4, REG SPLIT, SS	41A129	32

When ordering parts, specify Job Number,  
Door Number and Manufacture Date

# Header Assembly Continued

81D445, Manual, Bi-Part

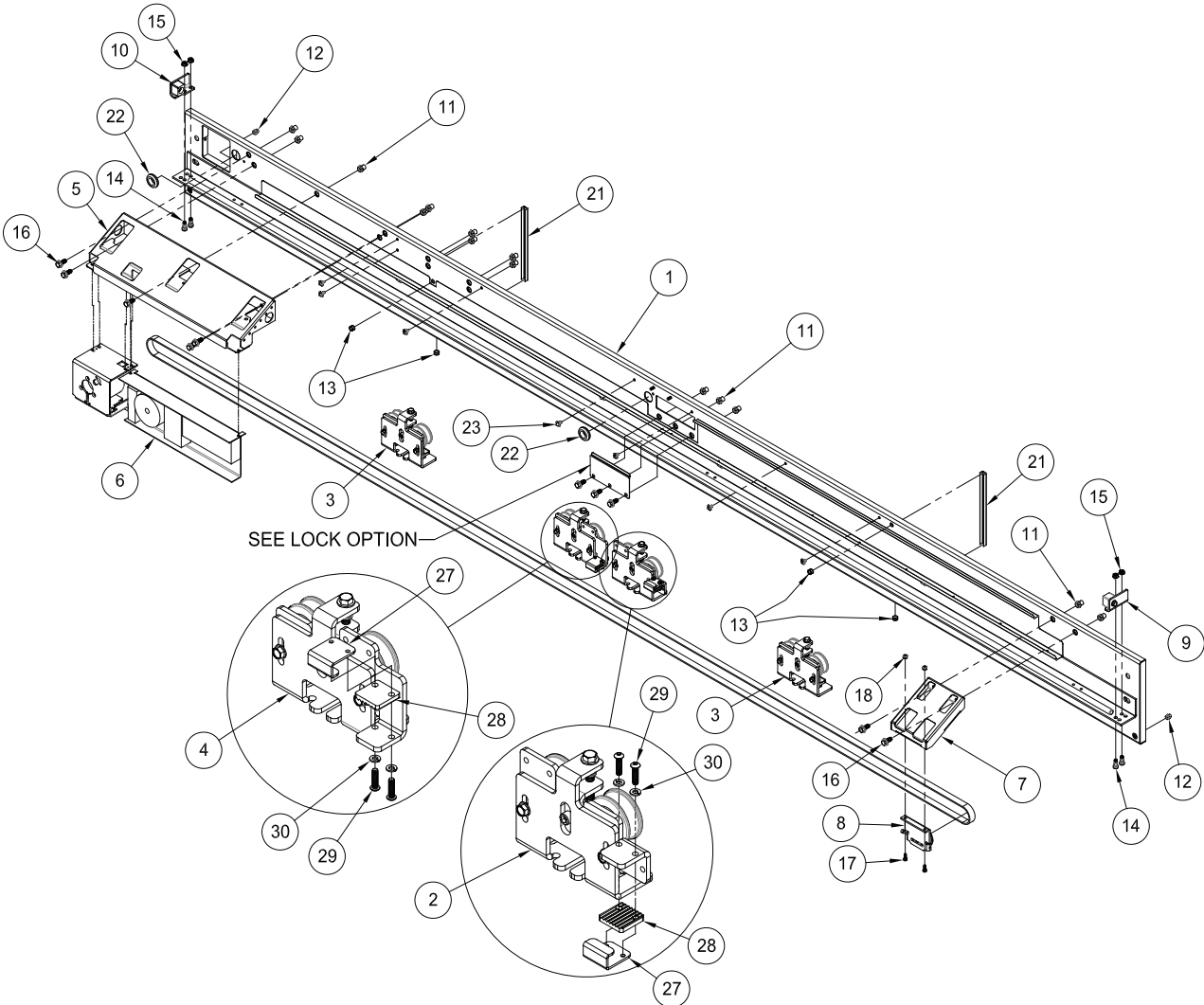

**When ordering parts, specify  
Job Number, Door Number and  
Manufacture Date**

REPLACEMENT  
PARTS

# Header Assembly Continued

## 81D440, Power, Bi-Part

F4	F3	F2	F1	DESCRIPTION	PART #	ITEM #
-	-	-	1	HEADER ASM, PWR RH SLIDE, 1250, STD, WIC <= 60	81D442F1	-
-	-	1	-	HEADER ASM, PWR RH SLIDE, 1250, AES, WIC <= 60	81D442F2	-
-	1	-	-	HEADER ASM, PWR RH SLIDE, 1250, STD, WIC > 60	81D442F3	-
1	-	-	-	HEADER ASM, PWR RH SLIDE, 1250, AES, WIC > 60	81D442F4	-
-	-	-	1	WELDMT, 1 PC HEADER, STD, PWR, BI-PART, EXCEL, WIC <= 60	28B217UF	1
-	-	1	-	WELDMT, 1 PC HEADER, AES, PWR, BI-PART, EXCEL, WIC <= 60	28B221UF	1
-	1	-	-	WELDMT, HEADER, STD, BI-PART, PWR, EXCEL, WIC > 60	28B196UF	1
1	-	-	-	WELDMT, HEADER, AES, BI-PART, PWR, EXCEL, WIC > 60	28B222UF	1
1	1	1	1	TROLLEY ASSEMBLY, RH, LEAD EDGE	24B198	2
2	2	2	2	TROLLEY ASSEMBLY, TRAILING EDGE	24B199	3
1	1	1	1	TROLLEY ASSEMBLY, LH, LEAD EDGE, BI-PART	24B208	4
1	1	1	1	WELDMT, OPERATOR MOUNT, 2301/2401 TORMAX	28B0263NN20	5
A/R	A/R	A/R	A/R	DRIVE OPTION, EXCEL, < 72", NO WASH DOWN	55B823F1	6
A/R	A/R	A/R	A/R	DRIVE OPTION, EXCEL, < 72", WITH WASH DOWN	55B823F2	6
A/R	A/R	-	-	DRIVE OPTION, EXCEL, >= 72", NO WASH DOWN	55B823F3	6
A/R	A/R	-	-	DRIVE OPTION, EXCEL, >= 72", WITH WASH DOWN	55B823F4	6
1	1	1	1	WELDMT, IDLER, EXCEL	28B157	7
1	1	1	1	IDLER BRACKET, PULLEY, EXCEL	13B1181UB	8
1	1	1	1	END STOP, RIGHT HAND, EXCEL	24B224	9
1	1	1	1	END STOP, LEFT HAND ASSY, EXCEL	24B223	10
14	14	14	14	INSERT, HEX, 3/8-16, GRIP RANGE .027-.150	41A788	11
2	2	2	2	INSERT, HEX, 1/4-20, GRIP RANGE .027-.165	41A784	12
4	4	4	4	GROMMET, .375" I.D.	11A128	13
4	4	4	4	SCREW, 3/8 X 3/8 SHSS SS	41A670	14
4	4	4	4	NUT, 5/16 WHIZLOCK, SS	41A712	15
7	7	7	7	SCREW, 3/8 X 1.00 HEX HEAD, WHIZLOCK, SS	41A793	16
8	8	8	8	SCREW, 1/4-20 x .625, HHMS, SS	41A303	17
8	8	8	8	NYLON INSERT LOCKNUT, 1/4-20 UNC	41A639	18
2	2	2	2	PHOTOEYE, TORMAX # US801343	23A367	19
1	1	1	1	CABLE, EXT, PHOTOEYE, AWG26, 3 METER	23A372	20
2	2	2	2	CHANNEL, COVER, PHOTOEYE WIRES	13B1805NN20	21
2	2	2	2	GROMMET, .875 ID	11A086	22
A/R	A/R	A/R	A/R	BASE, TY-RAP, CABLE TIE MOUNT, 1/4" Ø	22A0285	23
A/R	A/R	A/R	A/R	CABLE TIE, TY-RAP, 3.50" LONG	22A109-1	24
A/R	A/R	A/R	A/R	TAPE, ALUMINUM, 2" WIDE	10A015	25
A/R	A/R	A/R	A/R	OPTION, LOCK, PIN-BOLT, 1260/1270, BI-PART, PWR, NO BOLT LOCK	55B0110F3	26
A/R	A/R	A/R	A/R	OPTION, LOCK, PIN-BOLT, 1260/1270, BI-PART, PWR, BOLT LOCK	55B0110F4	26
2	2	2	2	BELT CLAMP, TROLLEY, BI-PART / SINGLE SLIDE	13B1063	27
2	2	2	2	BELT LOCK, TROLLEY, BI-PART / SINGLE	14B148	28
4	4	4	4	1/4-20 X 1.000 BUTTON-HEAD SCREW	41A757	29
4	4	4	4	WASHER, LOCK, 1/4, REG SPLIT, SS	41A129	30

**When ordering parts, specify  
Job Number, Door Number  
and Manufacture Date**

# Header Assembly Continued

## 81D440, Power, Bi-Part

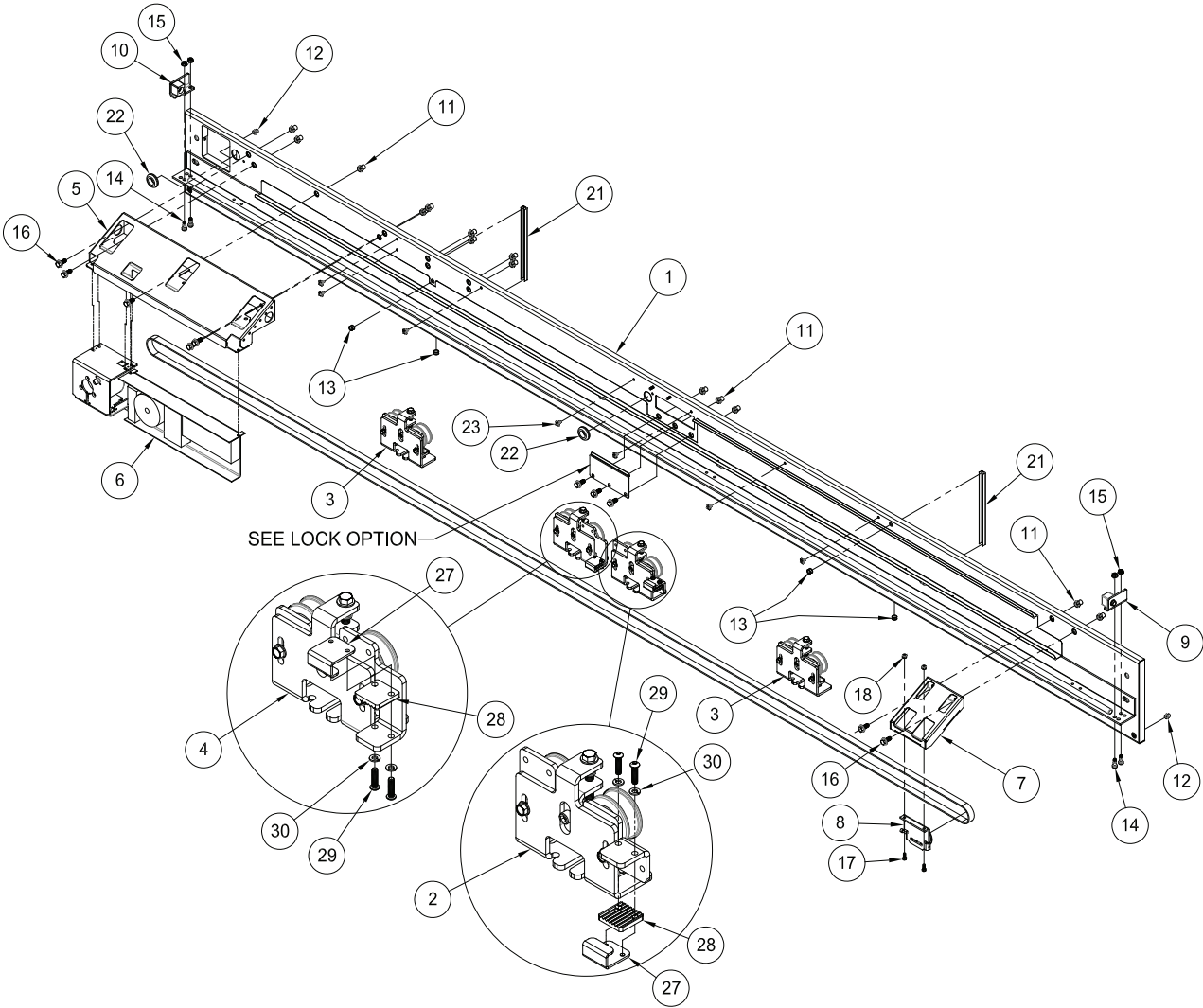

**When ordering parts, specify  
Job Number, Door Number and  
Manufacture Date**

REPLACEMENT  
PARTS

# Option , Lock, Manual, RH/LH

## 55B0110, Lock Assembly, Bi-Part

When ordering parts, specify  
Job Number, Door Number and  
Manufacture Date

F4	F3	F2	F1	DESCRIPTION	PART #	ITEM #
-	-	-	1	OPTION, LOCK, PIN-BOLT, MAN, BI-PART, NO BOLT LOCK	55B0110F1	-
-	-	1	-	OPTION, LOCK, PIN-BOLT, MAN, BI-PART, BOLT LOCK	55B0110F2	-
-	1	-	-	OPTION, LOCK, PIN-BOLT, PWR, BI-PART, NO BOLT LOCK	55B0110F3	-
1	-	-	-	OPTION, LOCK, PIN-BOLT, PWR, BI-PART, BOLT LOCK	55B0110F4	-
-	-	1	1	COVER, BOLT-LOCK CUTOUT, EXCEL	13B1809NN20	1
3	3	3	3	SCREW, 3/8 X 1.00 HEX HEAD, WHIZLOCK, SS	41A793	2
1	1	-	-	ASM, BOLT LOCK, 3/4" DIA., SDC 1190A	23A0376NN	3
-	1	-	-	BRACKET, BOLT LOCK, RH, EXCEL	13B1811RN20	4
1	-	-	-	BRACKET, SENSOR MOUNT	13B1810NN20	5
1	1	-	-	SENSOR, MAGNETIC, GE 1145 SERIES	23A0375NN	6
2	2	-	-	SCREW, #10-24 x .50, PH FHMS, SS	41A141	7
2	2	-	-	10-24 WHZLK NUT, SS	41A716	8
2	2	-	-	BRACKET, LATCH, RH SIDE, BP, BOLT LOCK, EXCEL	13B1815RN20	9
2	2	-	-	BRACKET, LATCH, LH SIDE, BP, BOLT LOCK, EXCEL	13B1814LN20	10
-	1	-	-	MNTG BLK, SENSOR MAGNET, BOLT-LOCK, EXCEL	11B0059NN	11
1	-	-	-	ASM, MAGNET & SCREW, REED SWITCH	23A283	12
1	1	-	-	SCREW, 1/4-20 X .750, PHL FHMS, SS	41A657	13
1	1	-	-	NYLON INSERT LOCKNUT, 1/4-20 UNC	41A639	14
1	1	-	-	SCREW, 1/4-20 X .875, FL WHIZLOCK, SS	41A844	15
2	2	-	-	NUT, 1/4-20, HEX, WHIZLOCK, S/S	41A711	16
2	2	-	-	BASE, TY-RAP, CABLE TIE MOUNT, 1/4" Ø	22A0285	17
2	2	-	-	CABLE TIE, TY-RAP, 3.50" LONG	22A109-1	18

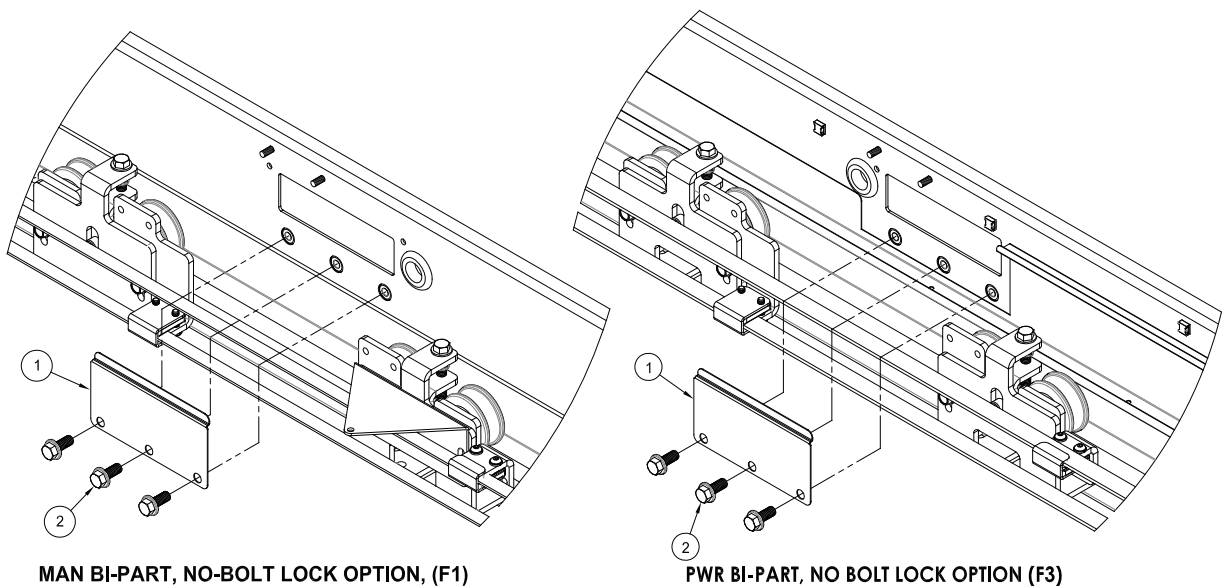

**55B0110, Lock Assembly, Bi-Part**

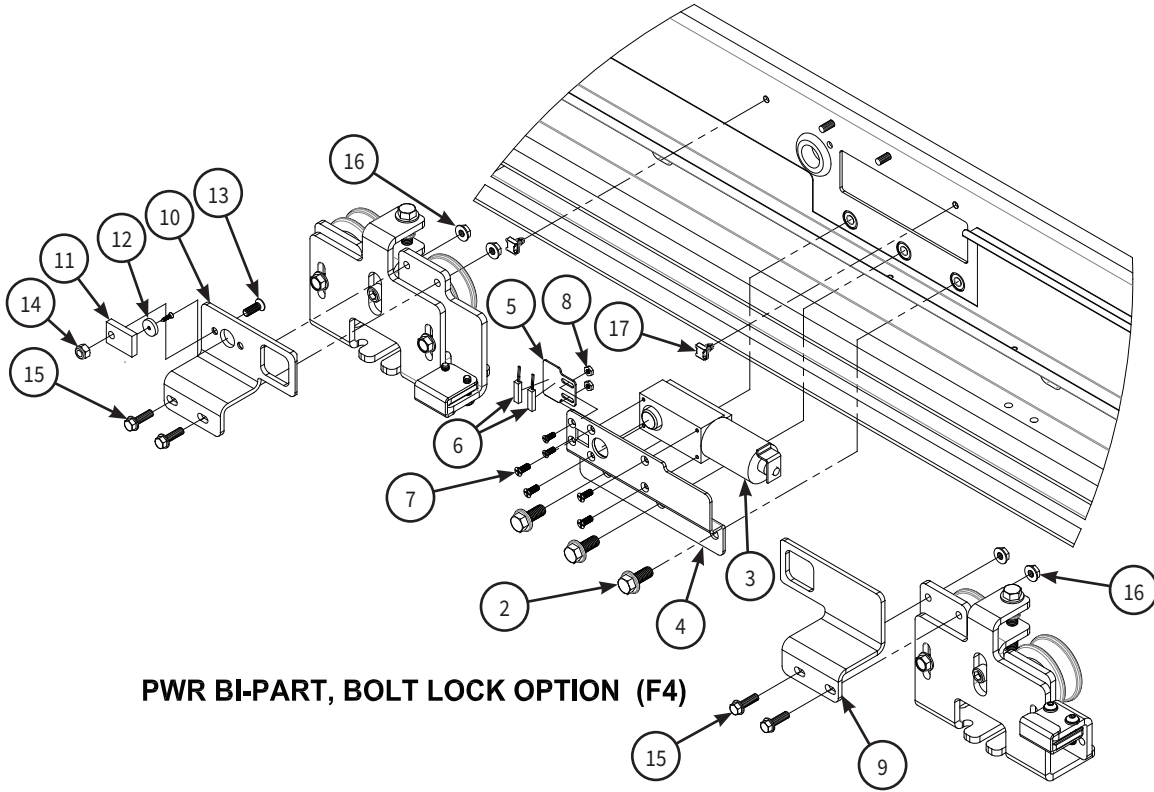
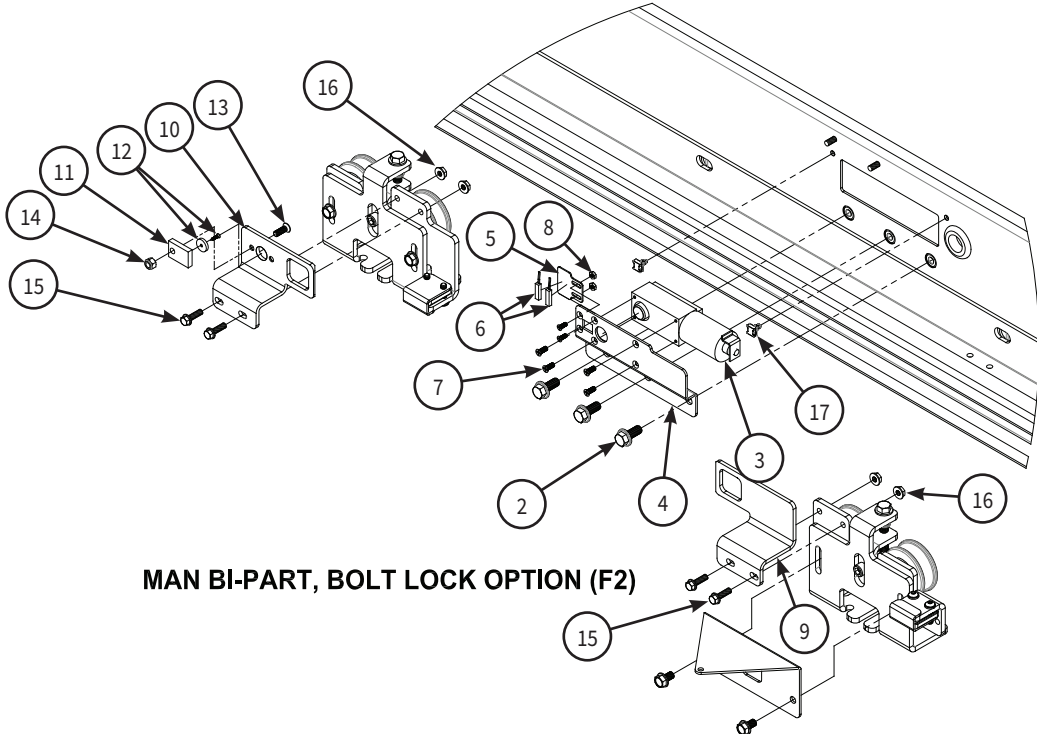

REPLACEMENT PARTS

# Shrouds

SHROUD ASSEMBLIES	PART#
SHROUD, PWR, LH CUTOUT, EXCEL, 0 DEG, <=5'	55B0844F1
SHROUD, PWR, LH CUTOUT, LXP, 0 DEG <=5'	55B0844F2
SHROUD, PWR, RH CUTOUT, EXCEL, 0 DEG <=5'	55B0844F3
SHROUD, PWR, RH CUTOUT, LXP, 0 DEG <=5'	55B0844F4
SHROUD, MANUAL, NO CUTOUT, EXCEL, 0 DEG <=5'	55B0844F5
SHROUD, MANUAL, NO CUTOUT, LXP, 0 DEG <=5'	55B0844F6
SHROUD, PWR, LH CUTOUT, EXCEL, 0 DEG, >5'	55B0844F7
SHROUD, PWR, LH CUTOUT, LXP, 0 DEG, >5'	55B0844F8
SHROUD, PWR, RH CUTOUT, EXCEL, 0 DEG, >5'	55B0844F9
SHROUD, PWR, RH CUTOUT, LXP, 0 DEG, >5'	55B0844F10
SHROUD, MANUAL, NO CUTOUT, EXCEL, 0 DEG, >5'	55B0844F11
SHROUD, MANUAL, NO CUTOUT, LXP, 0 DEG, >5'	55B0844F12
SHROUD, PWR, LH CUTOUT, EXCEL/LXP, 25 DEG, <=5'	55B0844F13
SHROUD, PWR, RH CUTOUT, EXCEL/LXP, 25 DEG <=5'	55B0844F14
SHROUD, MANUAL, NO CUTOUT, EXCEL/LXP, 25 DEG <=5'	55B0844F15
SHROUD, PWR, LH CUTOUT, EXCEL/LXP, 25 DEG, >5'	55B0844F16
SHROUD, PWR, RH CUTOUT, EXCEL/LXP, 25 DEG >5'	55B0844F17
SHROUD, MANUAL, NO CUTOUT, EXCEL/LXP, 25 DEG >5'	55B0844F18

SHROUD PARTS	PART#	ITEM #
WLDMT, SHROUD, 0 DEG, NO CUTOUT, EXCEL, <= 5'	28B0380NV	1
WLDMT, SHROUD, 0 DEG, NO CUTOUT, LXP, <= 5'	28B0376NV	2
WLDMT, SHROUD, 0 DEG, RH CUTOUT, EXCEL, <= 5'	28B0379RV	3
WLDMT, SHROUD, 0 DEG, RH CUTOUT, LXP, <= 5'	28B0375RV	4
WLDMT, SHROUD, 0 DEG, LH CUTOUT, EXCEL, <= 5'	28B0379LV	5
WLDMT, SHROUD, 0 DEG, LH CUTOUT, LXP, <= 5'	28B0375LV	6
WLDMT, SHROUD, 0 DEG, RH CUTOUT, EXCEL, WIC >5'	28B0381RV	7
WLDMT, SHROUD, 0 DEG, RH CUTOUT, EXCEL, WIC >5'	28B0377RV	8
WLDMT, SHROUD, 0 DEG, RH, NO CUTOUT, EXCEL, WIC >5'	28B0382RV	9
WLDMT, SHROUD, 0 DEG, RH, NO CUTOUT, LXP, WIC >5'	28B0378RV	10
WLDMT, SHROUD, 0 DEG, LH CUTOUT, EXCEL, WIC >5'	28B0381LV	11
WLDMT, SHROUD, 0 DEG, LH CUTOUT, LXP, WIC >5'	28B0377LV	12
WLDMT, SHROUD, 0 DEG, LH, NO CUTOUT, EXCEL, WIC >5'	28B0382LV	13
WLDMT, SHROUD, 0 DEG, LH, NO CUTOUT, LXP, WIC >5'	28B0378LV	14
WLDMT, SHROUD, 25 DEG, LH CUTOUT, WIC <=5'	28B0371LV	15
WLDMT, SHROUD, 25 DEG, RH CUTOUT, WIC <=5'	28B0371RV	16
WLDMT, SHROUD, 25 DEG, MANUAL, WIC <=5'	28B0374NV	17
WLDMT, SHROUD, 25 DEG, LH, NO CUTOUT, WIC >5'	28B0373LV	18
WLDMT, SHROUD, 25 DEG, PWR, LH CUTOUT, WIC >5'	28B0372LV	19
WLDMT, SHROUD, 25 DEG, PWR, RH CUTOUT, WIC >5'	28B0372RV	20
WLDMT, SHROUD, 25 DEG, RH, NO CUTOUT, WIC >5'	28B0373RV	21
SUPPORT, CENTER, SHROUD, 0 DEG, LXP	13B1832NN	22
SUPPORT, SHROUD, 25 DEG, LXP	13B1833NN	23
SUPPORT, SHROUD, 25 DEG, EXCEL	13B1834NN	24
SUPPORT, SHROUD, 0 DEG, EXCEL	13B2115NN	25
ASM, BRACKET, TOUCH-PAD, 2301/2401	24B0492NN	26
TOUCH-PAD, TORMAX	23A0363	27
SCREW, 1/4-20X .625, BU/HD, S/S	41A535	28

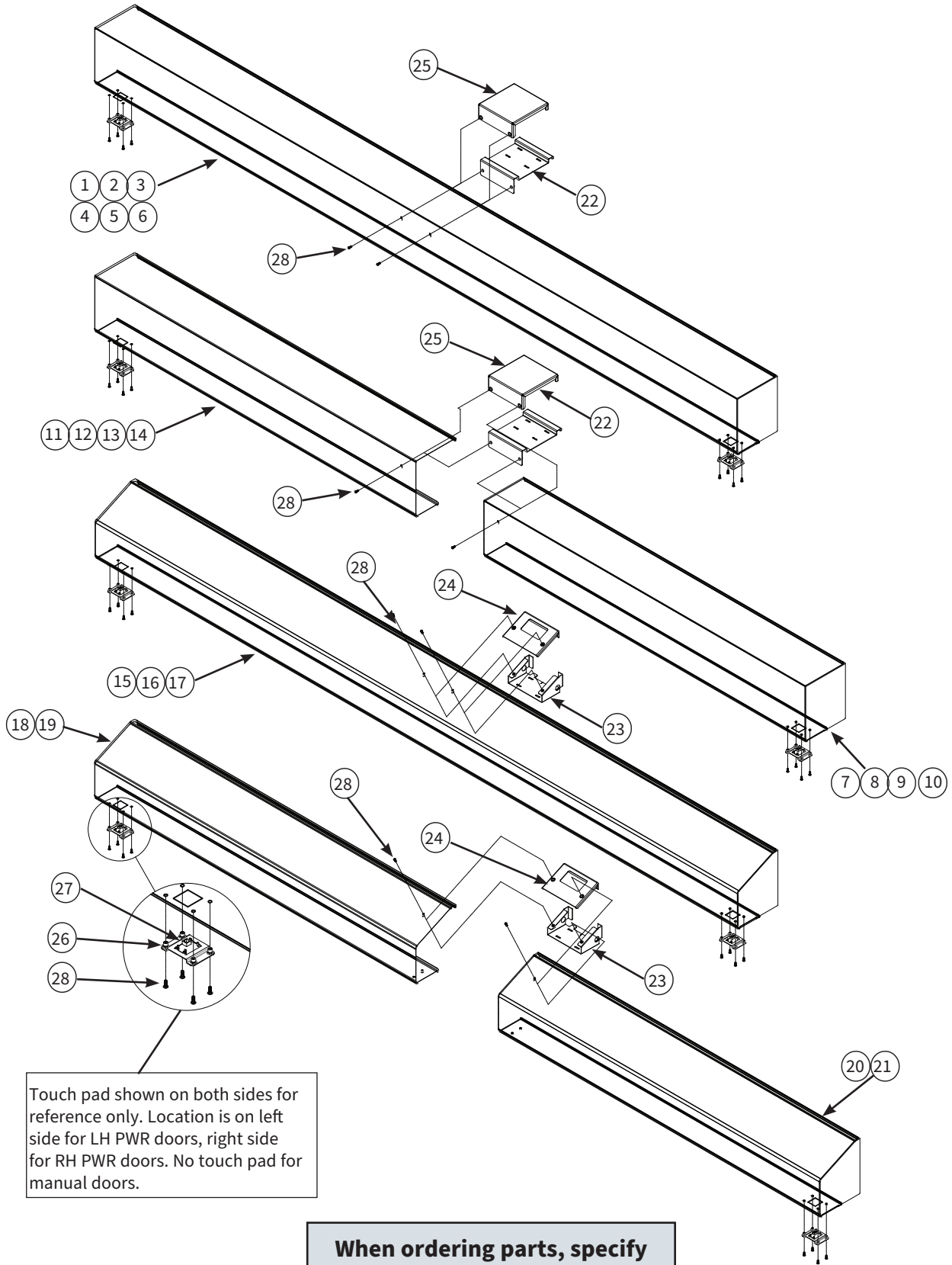

Touch pad shown on both sides for reference only. Location is on left side for LH PWR doors, right side for RH PWR doors. No touch pad for manual doors.

**When ordering parts, specify Job Number, Door Number and Manufacture Date**

# Seamless Molded Fiberglass Door Panel Assembly

DESCRIPTION	PART #	ITEM #
DOOR PANEL, 1-3/4", FIBERGLASS SKIN	32C670F2	1
DOOR PANEL, 1-3/4", STAINLESS STEEL	32C671F2	1
CAPPING, SIDE, BI-PART LEADING EDGE	13C443	2
CAPPING, TOP	13C441	3
CAPPING, TOP, LXP CANE-BOLT, BI-PART, RH	13B2200RV	4
CAPPING, TOP, LXP CANE-BOLT, BI-PART, LH	13B2200LV	4
CAPPING, SIDE, BI-PART TRAILING EDGE	13C440	5
CAPPING, BOTTOM	13C442	6
HANDLE, PULL, RECESSED	16B036	7
ASM GUIDE ROLLER, LH/RH, (WIC/2 + 2.00")	24B1102NV	8
RETAINER, GASKET, SIDE, L = HIC	44A012	9
RETAINER, GASKET, TOP, L = WIC/2 - 0.50"	44A012	10
GASKET, SEAL, BOTTOM, L = WIC + 5"	15A009	11
GASKET, SEAL, SIDE, L = HIC - 2.00"	15A009	12
GASKET, SEAL, TOP, L=WIC + 2.00"	15A009	13
PUSH PLATE OPTION	55B793	14
CANE-BOLT OPTION, W/EXIT INDICATOR, MAN	24C086F1	15
CANE-BOLT OPTION, W/EXIT INDICATOR, PWR	24C086F2	15
CANE-BOLT OPTION, W/EXIT INDICATOR & THUMB-TURN, MAN	24C086F2	15
CANE-BOLT OPTION, W/EXIT INDICATOR & THUMB-TURN, PWR	24C087F2	15
WINDOW OPTION, 1-3/4" FASTENERLESS	55B575	16
WINDOW OPTION, 1-3/4" FLUSH, CLEANVIEW	55B400	16
SCREW, HHCS, 3/8"-16 X 2.25", SS	41A719	17
WASHER, LOCK, 3/8", SS	41A327	18
WASHER, FLAT, 3/8" SS	41A203	19
SCREW, #10 X 1.00, PH FHSMS, SS	41A794	20
SCREW, PHSMS PHIL, #12 X 1.25", SS	41A481	21
TRACK, REVERSING EDGE, L = HIC - 2"	11B100	22
EXTRUSION, REVERSING EDGE, L=HIC	11B099	23
RETAINER, SWEEP GASKET, 45°, L=HIC - 2"	44A013	24
SCREW, FHSMS, #8 X 3/4", SS	41A024	25
ASM. BUMPER/BRACKET, BI-PART	24B155	26
SCREW, #8-32 X .375 PHL FHMS, SS	41A659	27

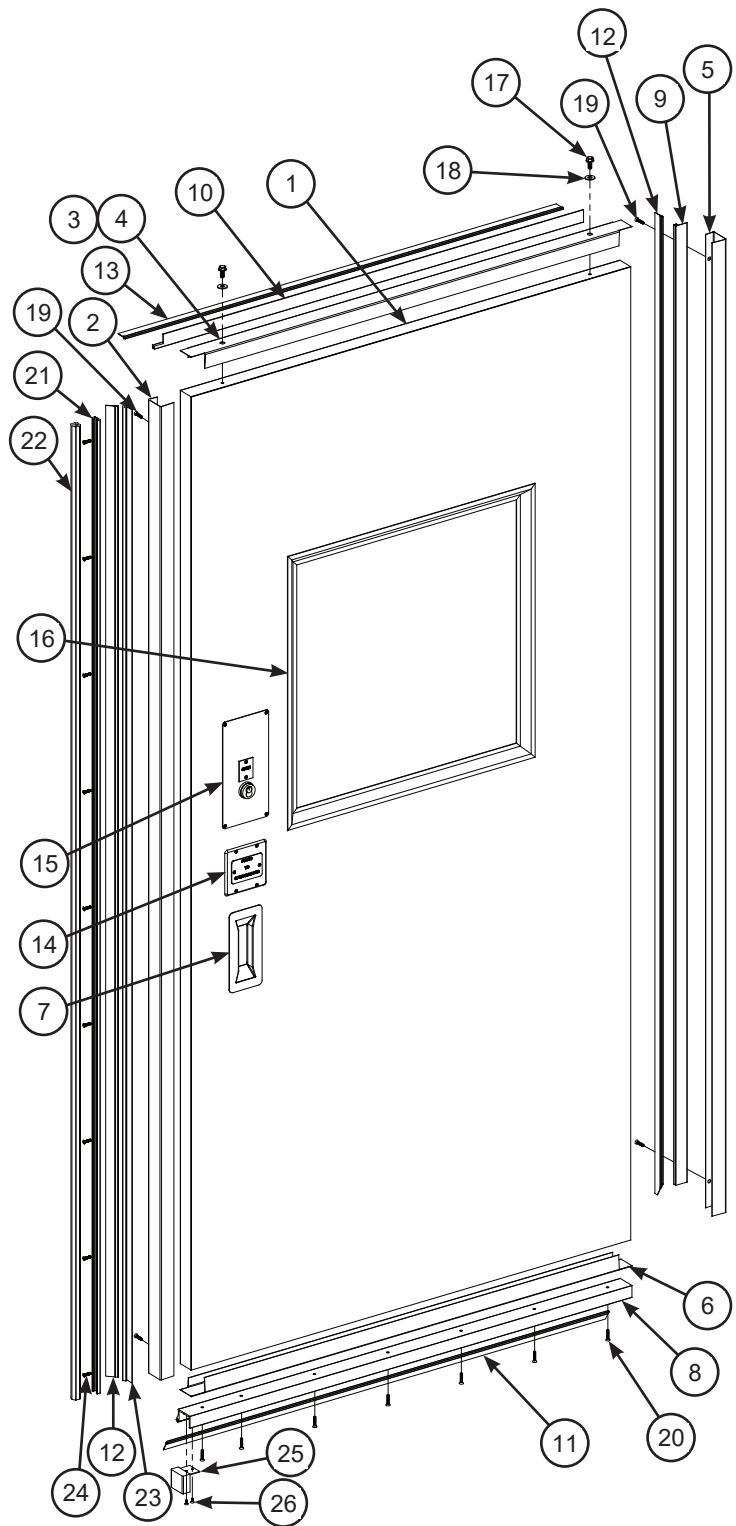

**When ordering parts, specify Job Number, Door Number and Manufacture Date**

**NOTE**

Note: RH door panel pictured. Specify RH or LH panel when ordering parts.

**REPLACEMENT PARTS**

# Seamless Molded Fiberglass Door Panel Assembly

DESCRIPTION	PART #	ITEM #
ASM, PANEL AND CHANNEL, BI-PART	32B003F2	1
CAPPING, LEAD EDGE, BI-PART	13B759	2
CAPPING, TOP, BI-PART	13B756F2	3
CAPPING, TOP, CANE-BOLT, BI-PART, RH	13B2200RV	4
CAPPING, TOP, CANE-BOLT, BI-PART, LH	13B2200LV	4
CAPPING, SIDE, LXP	13B758	5
CAPPING, BOTTOM, BI-PART	13B757F2	6
HANDLE, PULL, RECESSED	16B036	7
EXTRUSION, ROLLER GUIDE, WIC/2 + 2, RH	13B763F2	8
EXTRUSION, ROLLER GUIDE, WIC/2 + 2, LH	13B763F3	8
RETAINER, GASKET, SIDE, HIC - 1.38	44A012	9
RETAINER, GASKET, TOP, WIC/2 +.50	44A012	10
GASKET, SEAL, BOTTOM, L = WIC + 5"	15A009	11
GASKET, SEAL, SIDE, L = HIC - 2.00"	15A009	12
GASKET, SEAL, TOP, L = WIC + 2.00"	15A009	13
PUSH PLATE OPTION, IN-PANEL, LXP	55B0033F07	14
CANE-BOLT OPTION, LXP, MAN	55C0572F1	15
CANE-BOLT OPTION, W/ THUMB-TURN, LXP, MAN	55C0572F2	15
CANE-BOLT OPTION, LXP, PWR	55C0572F3	15
CANE-BOLT OPTION, W/ THUMB-TURN, LXP, PWR	55C0572F4	15
WINDOW OPTION, 1-3/4" FASTENERLESS	55B575	16
WINDOW OPTION, 1-3/4" FLUSH, CLEANVIEW	55B400	16
SCREW, 5/16-18 X 1.00, WHZLK	41A571	17
WASHER, FLAT, 5/16, ZN	41A126	18
SCREW, #10 X 1.00", PH FHSMS, S/S	41A794	19
SCREW, PHSMS PHIL, #12 X 1.25", S/S	41A481	20
TRACK, REVERSING EDGE, HIC + 2"	11B100	21
EXTRUSION, REVERSING EDGE, HIC + 2"	11B099	22
RETAINER, SWEEP GASKET, 45°, HIC + 2"	44A013	23
SCREW, FHSMS, #8 X 3/4", S/S	41A024	24
ASM., BUMPER/BRACKET, BI-PART	24B155	25
SCREW, #8-32X.375, PHL FHMS, S/S	41A659	26

**When ordering parts, specify  
Job Number, Door Number and  
Manufacture Date**

## NOTE

**Note:** RH door panel pictured. Specify RH or LH panel when ordering parts.

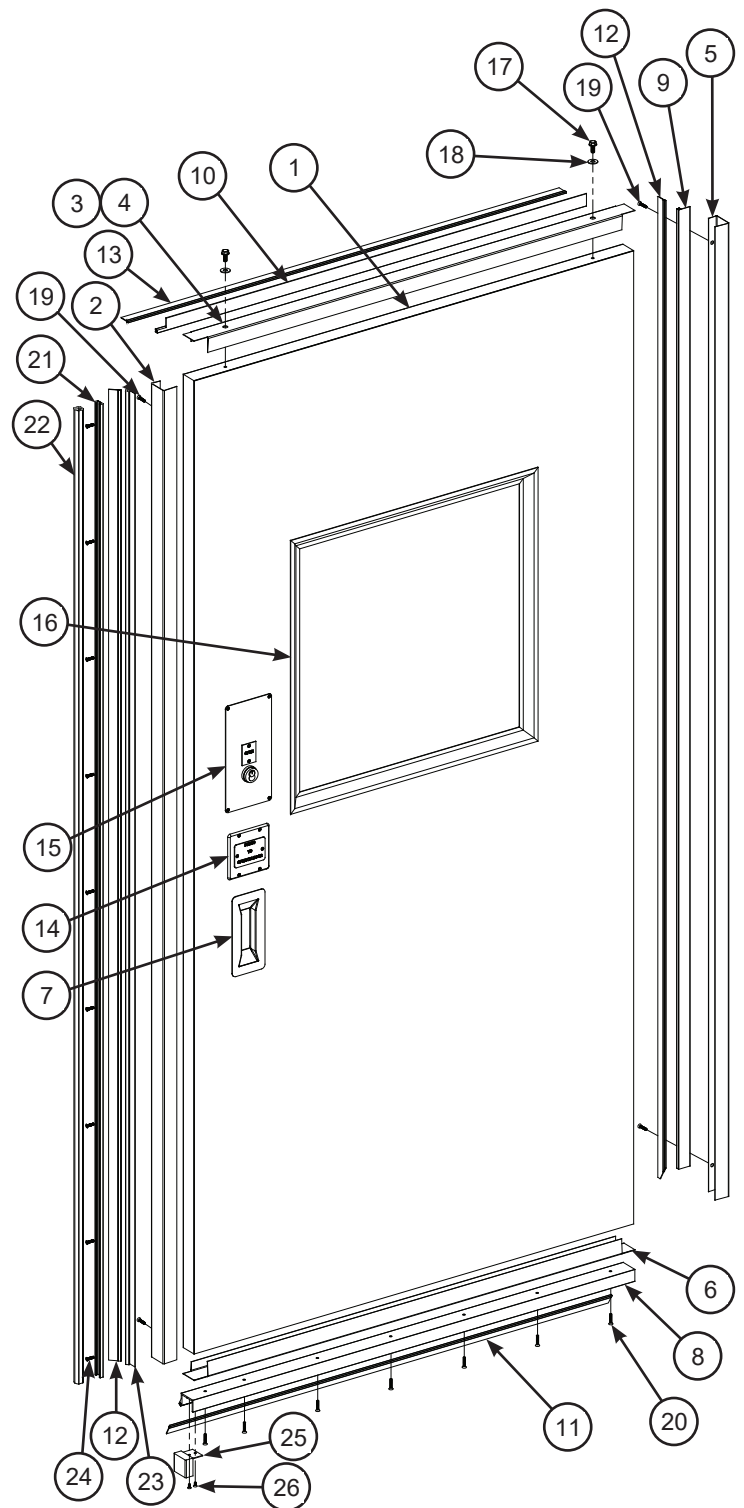

# Face Frame Assemblies

QTY						DESCRIPTION	PART #	ITEM #
-	-	-	-	-	X	ASSY, FACE FRAME, 2 P/E, POWER, RH	76B0005RV	-
-	-	-	-	X	-	ASSY, FACE FRAME, 2 P/E, POWER, LH	76B0005LV	-
-	-	-	X	-	-	ASSY, FACE FRAME, 0 P/E, MANUAL, RH	76B0006RV	-
-	-	X	-	-	-	ASSY, FACE FRAME, 0 P/E, MANUAL, LH	76B0006LV	-
-	X	-	-	-	-	ASSY, FACE FRAME, 4 P/E, POWER, RH	76B0036RV	-
X	-	-	-	-	-	ASSY, FACE FRAME, 4 P/E, POWER, LH	76B0036LV	-
-	1	-	1	-	1	WELDMENT, FACE FRAME, RH	28B0335R	1
1	-	1	-	1	-	WELDMENT, FACE FRAME, LH	28B0335L	1
-	-	-	-	-	1	COVER, FACE FRAME, 2 P/E, RH, PWR	13B1792RV20	2
-	-	-	-	1	-	COVER, FACE FRAME, 2 P/E, LH, PWR	13B1792LV20	2
-	-	1	1	-	-	COVER, FACE FRAME, RH/LH, MANUAL	13B1793NV20	2
-	1	-	-	-	-	COVER, FACE FRAME, 4 P/E, RH, PWR	13B1877RV20	2
1	-	-	-	-	-	COVER, FACE FRAME, 4 P/E, LH, PWR	13B1877LV20	2
1	1	1	1	1	1	ASM, ADJUSTABLE FLOOR ROLLER	24B210	3
2	2	-	-	1	1	PHOTOEYE, TORMAX # US801343	23A367	4
1	1	-	-	1	1	LABEL, PHOTOEYE INSTALLATION	17B037	5
2	2	2	2	2	2	PANEL NUT, 10-24, .025-.063 THK	41A900	6
2	2	2	2	2	2	SCREW, 10-24 X .625, PHMS, S/S	41A883	7
2	2	2	2	2	2	NUT, 1/4-20, HEX, NYLOCK, S/S	41A639	8

**When ordering parts, specify Job Number, Door Number and Manufacture Date**

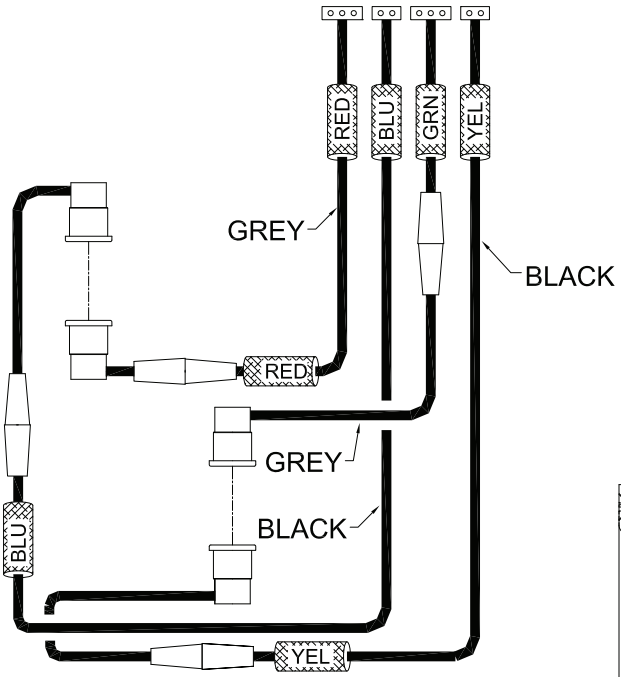

Photoeye wiring - Only used on Power models.

**NOTE**  
 Note: consult ASI service for specific face frame assemblies appropriate for your specific door installation.

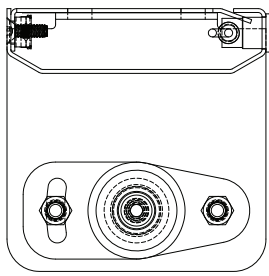

RH Slide Lead Edge Face Frame Top View

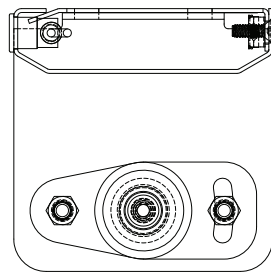

LH Slide Lead Edge Face Frame Top View

REPLACEMENT PARTS

# Face Frame Assemblies continued

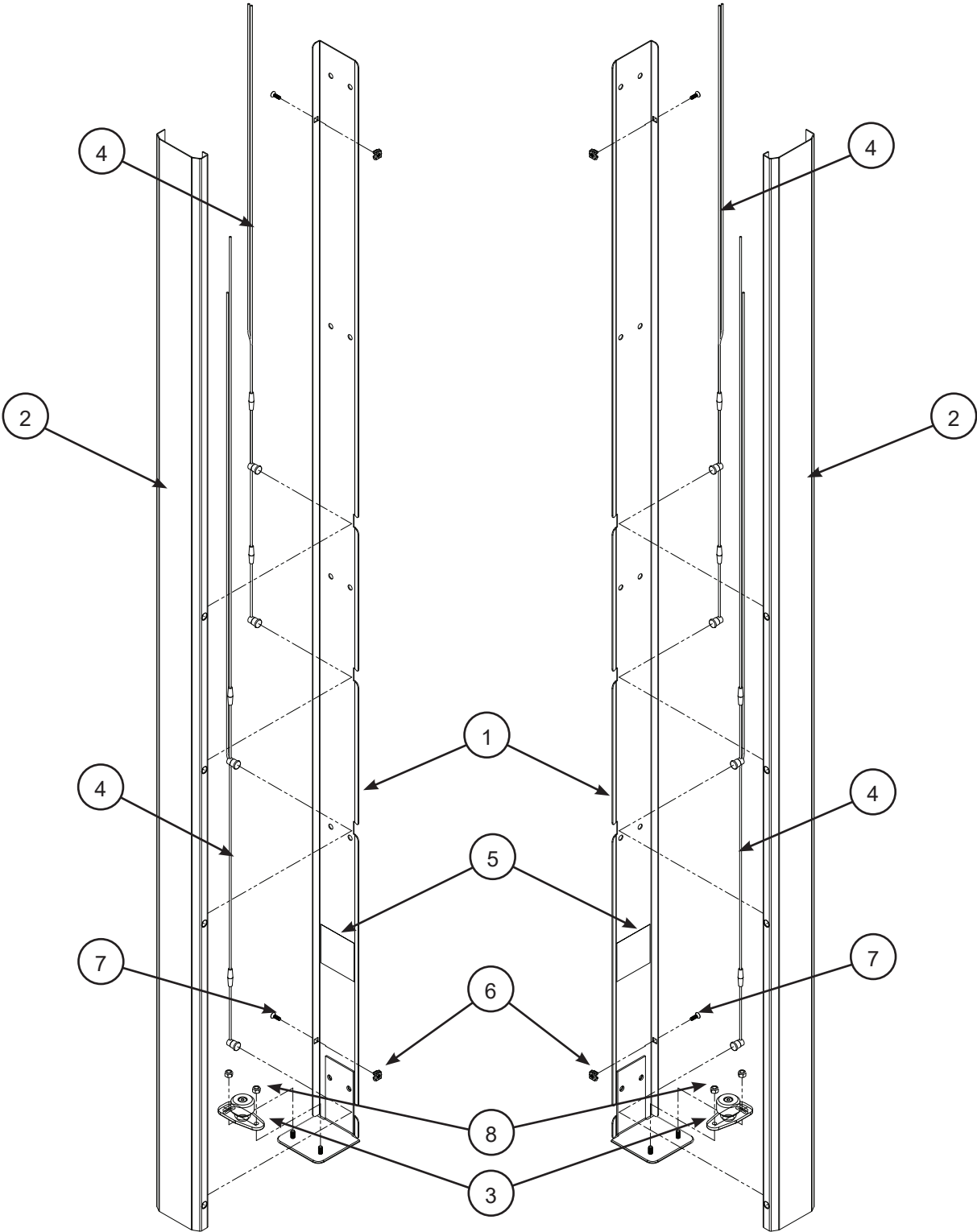

REPLACEMENT PARTS

# Face Frame Assemblies, Trail Edge

QTY						DESCRIPTION	PART #	ITEM #
-	-	-	-	-	X	ASSY, FACE FRAME, 2 P/E, POWER, RH	76B0005RV	-
-	-	-	-	X	-	ASSY, FACE FRAME, 2 P/E, POWER, LH	76B0005LV	-
-	-	-	X	-	-	ASSY, FACE FRAME, 0 P/E, MANUAL, RH	76B0006RV	-
-	-	X	-	-	-	ASSY, FACE FRAME, 0 P/E, MANUAL, LH	76B0006LV	-
-	X	-	-	-	-	ASSY, FACE FRAME, 4 P/E, POWER, RH	76B0036RV	-
X	-	-	-	-	-	ASSY, FACE FRAME, 4 P/E, POWER, LH	76B0036LV	-
-	1	-	1	-	1	WELDMNT, FACE FRAME , RH	28B0335R	1
1	-	1	-	1	-	WELDMNT, FACE FRAME, LH	28B0335L	1
-	-	-	-	-	1	COVER, FACE FRAME, 2 P/E, RH, PWR	13B1792RV20	2
-	-	-	-	1	-	COVER, FACE FRAME, 2 P/E, LH, PWR	13B1792LV20	2
-	-	1	1	-	-	COVER, FACE FRAME, RH/LH, MANUAL	13B1793NV20	2
-	1	-	-	-	-	COVER, FACE FRAME, 4 P/E, RH, PWR	13B1877RV20	2
1	-	-	-	-	-	COVER, FACE FRAME, 4 P/E, LH, PWR	13B1877LV20	2
1	1	1	1	1	1	ASM, ADJUSTABLE FLOOR ROLLER	24B210	2
2	2	-	-	1	1	PHOTOEYE, TORMAX # US801343	23A367	4
1	1	-	-	1	1	LABEL, PHOTOEYE INSTALLATION	17B037	5
2	2	2	2	2	2	PANEL NUT, 10-24, .025-.063 THK	41A900	6
2	2	2	2	2	2	SCREW, 10-24 X .625, PHMS, S/S	41A883	7
2	2	2	2	2	2	NUT, 1/4-20, HEX, NYLOCK, S/S	41A639	8

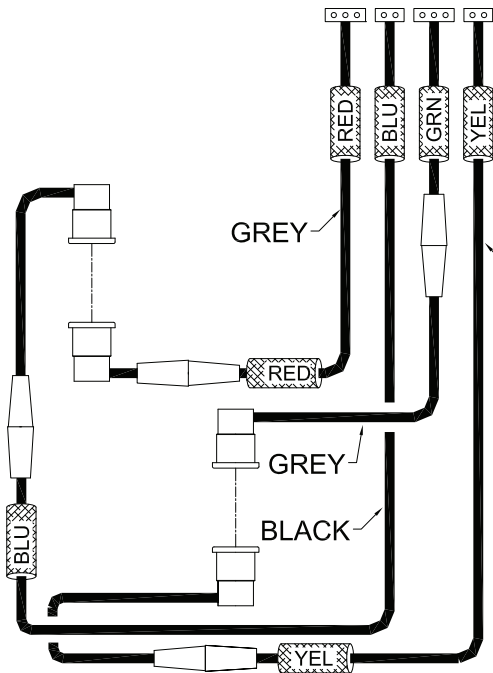

Photoeye wiring - Only used on Power models.

**When ordering parts, specify Job Number, Door Number and Manufacture Date**

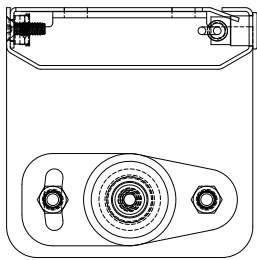

RH Slide Trail Edge Face Frame Top View

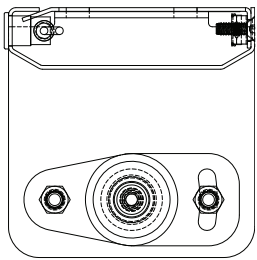

LH Slide Trail Edge Face Frame Top View

**NOTE**

**Note** consult ASI service for specific face frame assemblies appropriate for your specific door installation.

# Option, Battery Backup

## 55B0103, Optional Battery Backup

QTY	DESCRIPTION	PART #	ITEM #
1	BRKT, BATTERY, TORMAX 2301/2401, EXCEL	13B1487NN20	1
1	BATTERY BACKUP, TORMAX 2301/2401	23A0368NN	2
4	SCREW, 3/8 X 1.00 HEX HEAD, WHIZLOCK, SS	41A793	3
2	SCREW, 1/4-20 x .625, HHMS, SS	41A303	4
2	NYLON INSERT LOCKNUT, 1/4-20 UNC	41A639	5

**NOTE**

**Note** minimum WIC for Battery Module is 4' 0"

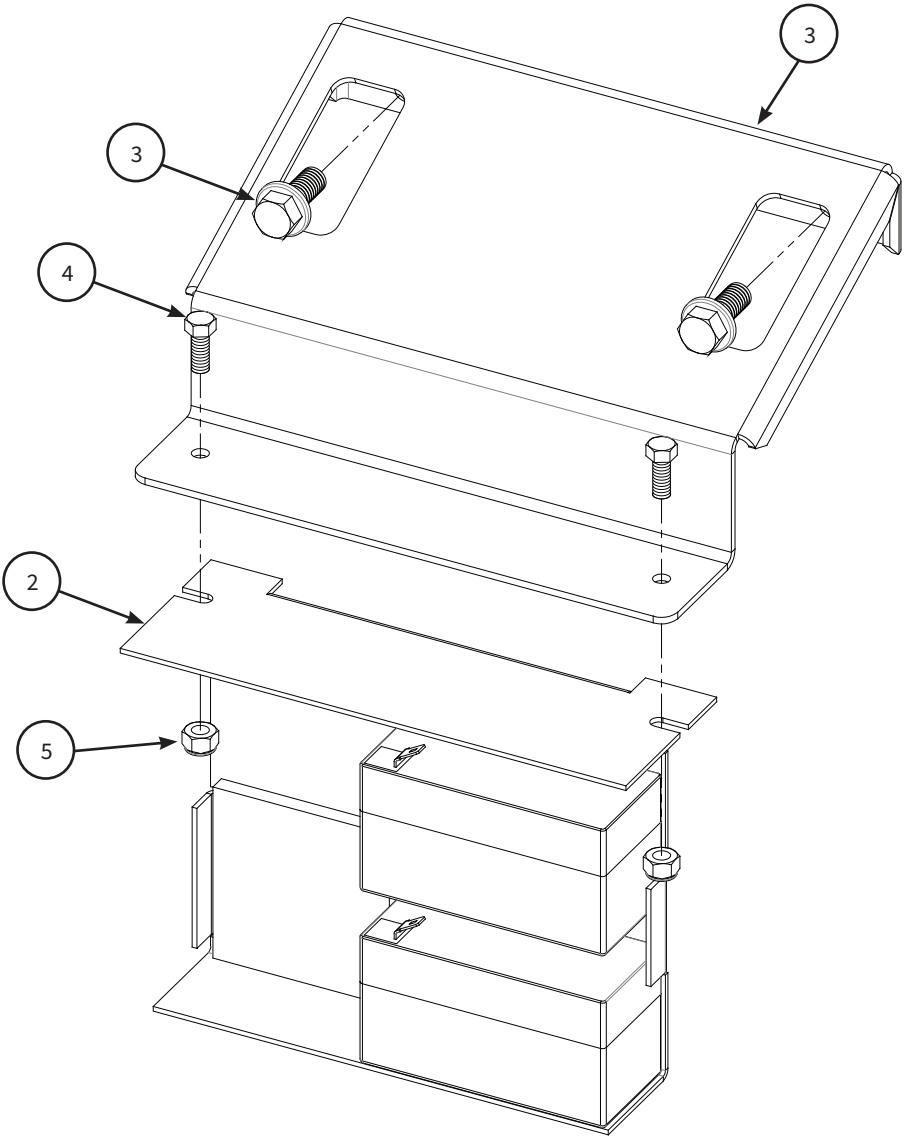

**When ordering parts, specify  
Job Number, Door Number  
and Manufacture Date**

# Option, Interlock Module

## 55B0104, Optional Interlock Module

F3	F1	DESCRIPTION	PART#	ITEM#
-	1	ASM, INTERLOCK MODULE, 2301/2401, EXCEL, 1 RELAY	55B0104F1	-
1	-	ASM, INTERLOCK MODULE, 2301/2401, EXCEL, 2 RELAYS	55B0104F3	-
1	-	BRACKET, INTERLOCK MODULE, EXCEL	13B2110NN20	1
1	-	PLATE, SPLICE, INTERLOCK MODULE, EXCEL	13A0461NN20	2
1	-	DIN RAIL, 35MM, 1.5" LONG	22B025	3
2	1	SOCKET, RELAY, FINDER # 95.05	23A232	4
2	1	RELAY, 24VDC, 2P, FINDER # 40.52.9.024.0000	23A126	5
2	1	SUPPRESSOR, RC, 6-24 VAC/VDC, FINDER # 9902002409	23A241	6
2	-	STOP, DIN RAIL	22A008	7
2	-	SCREW, 1/4-20 X .625, BHS, SS	41A535	8
2	-	NYLON INSERT LOCKNUT, 1/4-20 UNC	41A639	9
2	-	SCREW, #10-24 X .625, SHCS, SS	41A715	10
2	-	10-24 WHZLK NUT, SS	41A716	11

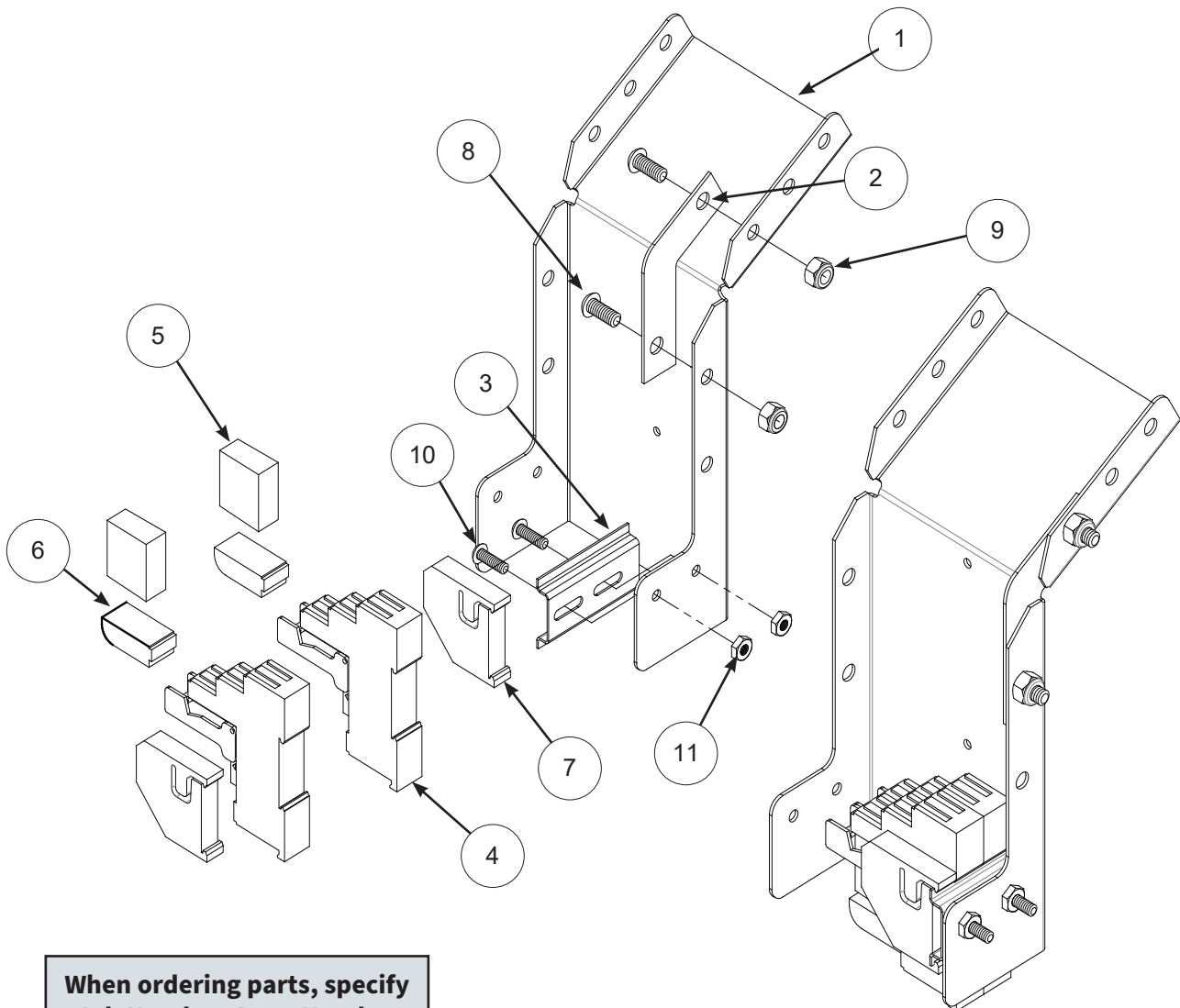

**When ordering parts, specify  
Job Number, Door Number  
and Manufacture Date**



**OPEN UP TO WHAT'S POSSIBLE**



**asidoors.com**