



OWNER'S MANUAL

MODEL 265

Bi-Parting Sliding U.L. Rated Fire Door

GENERAL INFORMATION 3-6

Safety Practices 3

Warranty Policy 5

Crates and Contents 6

265 MANUAL INSTALLATION 7-19

Door Measurements 7

Frame and Header Assembly 8

Initial Electrical Connections 9

Panel Installation 10

Shroud Installation 11

Panel Adjustment 12

Electrical Controls 13

PLC Inputs 15

PLC Outputs 17

Other Electrical Functions 18

Star-Up 19

MAINTENANCE 21-22

Inspection 21

Preventative 21

Troubleshooting 22

REPLACEMENT PARTS 23-35

Instructions for Ordering 23

Door Identification 24

ID Tag Location 24

Door Assembly 25

Door Panel Assembly 26

Face Frame Assembly 28

Header Assembly & Shrouds 30

Upper Truck Assembly 32

Labels 32

Gasket Retainer/Hold-In Brackets 33

Control Panel Assembly 34

Fire/Heat Sensor Options 35

Safety Practices



This is a safety alert symbol. It is used to alert you to potential personal injury hazards. Obey all safety messages that follow this symbol to avoid possible injury or death.

DANGER

DANGER indicates an imminently hazardous situation which, if not avoided, will result in death or serious injury.

WARNING

WARNING indicates a potentially hazardous situation which, if not avoided, could result in death or serious injury.

CAUTION

CAUTION indicates a potentially hazardous situation which, if not avoided, may result in minor or moderate injury.

CAUTION

CAUTION used without a safety alert symbol indicates a potentially hazardous situation which, if not avoided, may result in property damage.

NOTE

NOTE explains general information.

▲ WARNING

Warning read these safety practices before installing, operating or servicing the SLIDING door. Failure to follow these safety practices could result in property damage, death or serious injury.

READ AND UNDERSTAND ALL WARNING LABELS AND OPERATING INSTRUCTIONS IN THIS MANUAL BEFORE OPERATING THE SLIDING DOOR. If you do not understand the instructions, ask your supervisor to teach you how to use the SLIDING door.

Safety Practices (cont'd)

1. Do not operate the door while under the influence of drugs or alcohol.
2. Do not use the door if it looks broken or does not seem to work properly. Advise your supervisor at once.
3. Stay clear of the door when it is moving
4. Keep hands, feet and head clear of the door at all times.
5. Do not operate the door with equipment, material or people directly inside door opening.
6. Disconnect power before performing any electrical or mechanical service, cleaning or other maintenance on the door. OSHA requires disconnect to be properly tagged and locked out during all maintenance or service of equipment. With the power supply disconnected, always verify using a volt meter.
7. All electrical troubleshooting or service must be completed by a qualified electrician or service person and must meet all applicable local, state, federal, international and other governing agency codes.
8. When it is necessary to service the control box with power on, USE EXTREME CAUTION. Do not place fingers or uninsulated tools inside the control box. Touching wires or other parts inside the enclosure may cause electrical shock, serious injury or death.
9. It is your responsibility to keep all warning labels and instructional literature legible, intact and kept with the door. Replacement labels and literature are available from ASI Doors, Inc. or its representatives.
10. If you have any questions, contact your supervisor or your local ASI Doors, Inc. representative for assistance.
11. Train all service and personnel using or near door on intended use(s) and operation of the door.
12. Failure to operate the door as intended, as described, or heed any warning may result in equipment damage, property damage, serious bodily injury or death.

Warranty Policy

ASI Doors (herein called “ASI”) warrants solely for the benefit of its customer that each door system manufactured by ASI (each a “Door System”) will be free from defects in material and manufacture for a period of one (1) year from the date of original shipment by ASI. The following models receive a similar two (2) years from date of shipment warranty: 109, 209, 120-125, 1240-125-, 1240SS-1250SS, 1260-1270, 1260SS-1270SS, 130-135, 140-150, 160-170, 220-225, 220SS-225SS, 230-235, 230SS-235SS. In all instances warranty labor is covered for a period of one (1) year from the date of original shipment.

The foregoing limited warranty shall not apply to defects that result from improper installation, abuse, misuse, alteration, modification, or failure to maintain the Door System in accordance with the ASI Owner’s Manual. Periodic maintenance and adjustment of the Door System as described in the ASI Owner’s Manual are the sole responsibility of the customer. All claims for defects must be made to ASI within thirty (30) days after the defect is discovered or should, with reasonable care, have been discovered. **THE FOREGOING LIMITED WARRANTY CONSTITUTES THE EXCLUSIVE WARRANTY OF ASI WITH RESPECT TO THE DOOR SYSTEM. ASI EXPRESSLY DISCLAIMS ALL OTHER GUARANTEES OR WARRANTIES—WHETHER EXPRESSED, IMPLIED, OR STATUTORY, INCLUDING BUT NOT LIMITED TO ANY IMPLIED WARRANTY OF MERCHANTABILITY AND FITNESS FOR A PARTICULAR PURPOSE.**

If a Door System does not comply with the foregoing limited warranty, and a claim is made by customer within the warranty period, ASI will, at the option of ASI, either repair or replace any defective equipment or parts free of charge and pay the reasonable labor costs to repair or replace the defective equipment or parts if within the defined warranty period. The remedy of repair or replacement shall be the exclusive and sole remedy for any breach of the foregoing limited warranty.

ASI SHALL NOT IN ANY EVENT BE LIABLE FOR ANY INCIDENTAL, INDIRECT, SPECIAL, EXEMPLARY OR CONSEQUENTIAL DAMAGES OF ANY KIND, INCLUDING WITHOUT LIMITATION ANY LOST PROFITS, ARISING FROM THE SALE OR USE OF THE DOOR SYSTEM, OR FROM ANY OTHER CAUSE WHATSOEVER, WHETHER THE CLAIM GIVING RISE TO SUCH DAMAGES IS BASED UPON BREACH OF WARRANTY (EXPRESSED OR IMPLIED) BREACH OF CONTRACT, TORT, STRICT LIABILITY OR ANY OTHER THEORY OF LIABILITY, EVEN IF A PARTY HAS BEEN ADVISED OF THE POSSIBILITY THEREOF, AND REGARDLESS OF ANY ADVISE OR REPRESENTATION THAT MAY HAVE BEEN RENDERED BY ASI CONCERNING THE SALE OR USE OF THE DOOR SYSTEM.

At ASI’s request, customer shall return to ASI for inspection any Door System for which a warranty claim has been made, F.O.B. ASI’s facility with freight prepaid. The customer is responsible for any removal costs.

The customer shall comply with the following procedures in filing a warranty claim with ASI:

1. Notify ASI of any and all defects in writing with photographic evidence. ASI will review the warranty request and issue a Returns Merchandise Authorization (RMA) form if the defective parts need to be returned to ASI for inspection and verification. The RMA form must accompany any materials returned for warranty consideration.
2. All replacement parts or equipment will be invoiced to the customer. Upon verification by ASI that the Door System is defective, ASI will issue a full credit to customer for the replacement parts or equipment.
3. If outside labor is needed to install the replacement parts or equipment, ASI requires a written estimate of the labor charges in advance so ASI may approve the labor charges and issue a purchase order. ASI will not accept any labor charges unless previously approved in writing and accompanied by the ASI purchase order number.

(Rev 12/21)

Crates and Contents

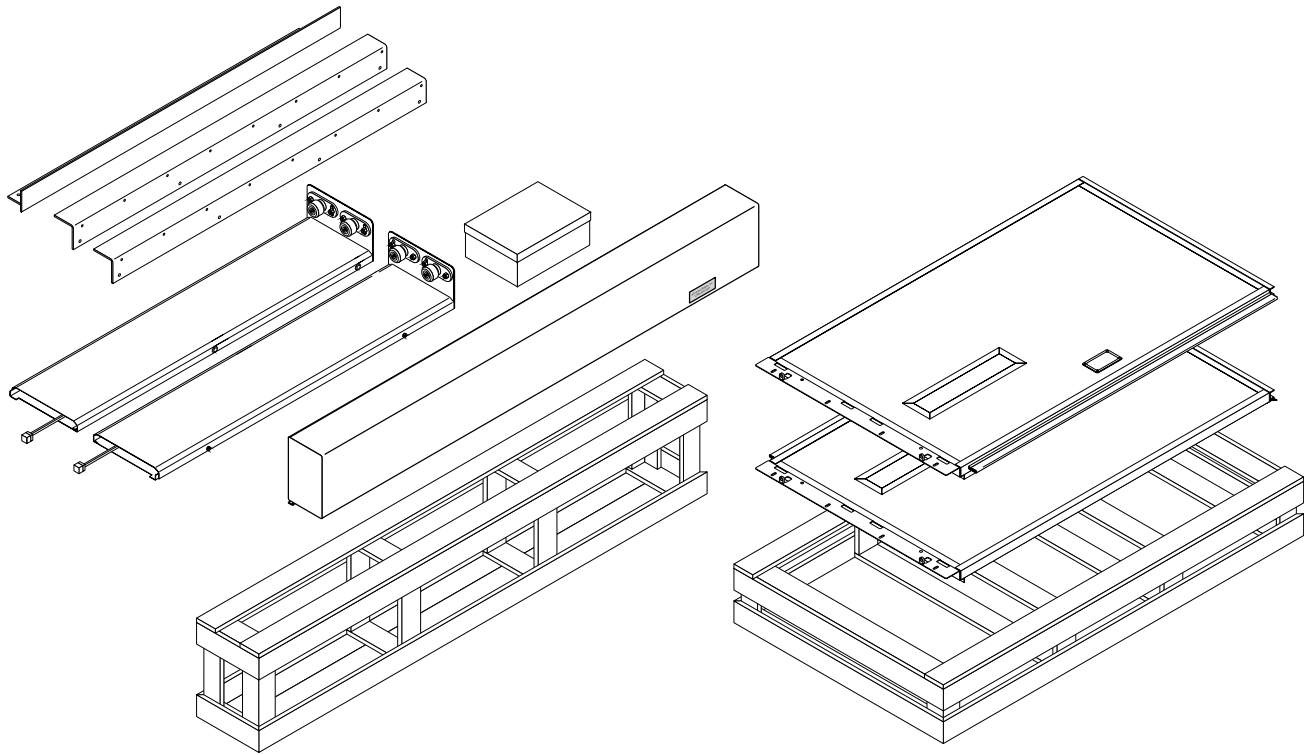

Figure 1: Crates and Contents

Upon receipt of the shipment, check that you have received the correct number of pieces as shown (Figure 1). Crate will contain the side-covers, the header assembly, the loose parts box, and control box. For your protection, note any damages or shortages on the carrier's bill of lading before signing the bill for receipt.

The installation of this door will require at least a two man crew and a fork-lift. Select a fork-lift with lifting height based upon the height of the door, plus a minimum additional two feet.

NOTE

Note because of variances in the construction of walls on which the door will be mounted, fasteners are not supplied. For proper anchoring of the door, we recommend the use of thru-bolts. **DO NOT** remove door sections from crate until you encounter the step in which they are to be installed.

Note unless specifically called out as "Provided by ASI", installer is to provide all necessary mounting hardware, anchors, inserts, hangers, supports and equipment needed to install door in accordance with final shop drawings and manufacturer's instructions.

Door Measurements

1. Measure door opening to verify door dimensions (Figure 3 & 5). Based upon dimensions in Figure 3, determine that door will have sufficient wall space to open. Locate side frames relative to the sides of the opening as shown in Figure 2.

WARNING

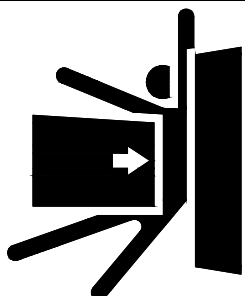

1. Read, study and understand all warning labels, operating instructions and installation manuals furnished with this equipment prior to use. If any portion of this material is unclear, contact your factory representative for clarification.
2. This is an automatic sliding door designed for vehicular and pedestrian traffic. Operation may be automatic. Keep doorway clear at all times. Door impact may cause personal injury or property damage.
3. Do not activate door unless doorway is clear. Once door has begun closing, **DO NOT ENTER DOORWAY!**
4. Keep clear of trailing edge of door at all times. Do not touch door while door is moving.
5. Check reversing edge, photoeye, and any other activation device for proper operation daily. See operating instructions for procedure.
6. Do not operate door with face frames open or without factory provided shrouds properly installed.
7. It is your responsibility to keep all warning labels and instructional literature legible and intact. Replacement labels and literature are available from the factory.
8. Failure to heed these warnings may result in equipment and/or property damage and/or personal or fatal injury.

ASI DOORS INC. 17C018

Figure 2: Warning Label (Located on Face of Leading Edge Wall Clip)

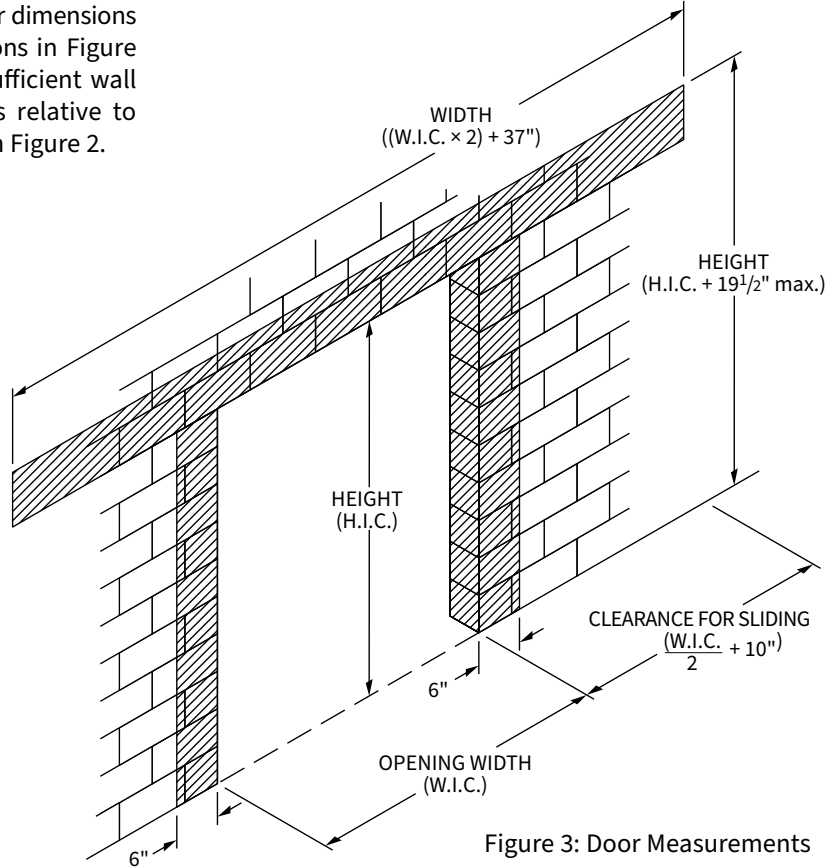

Figure 3: Door Measurements

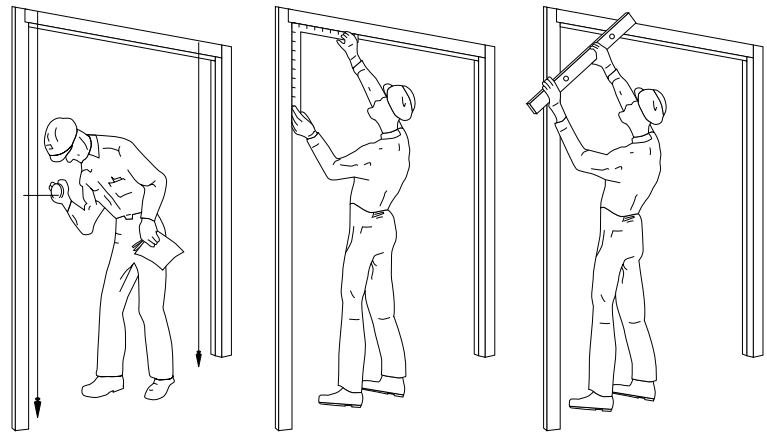

Figure 4: Checking Plumb and Square

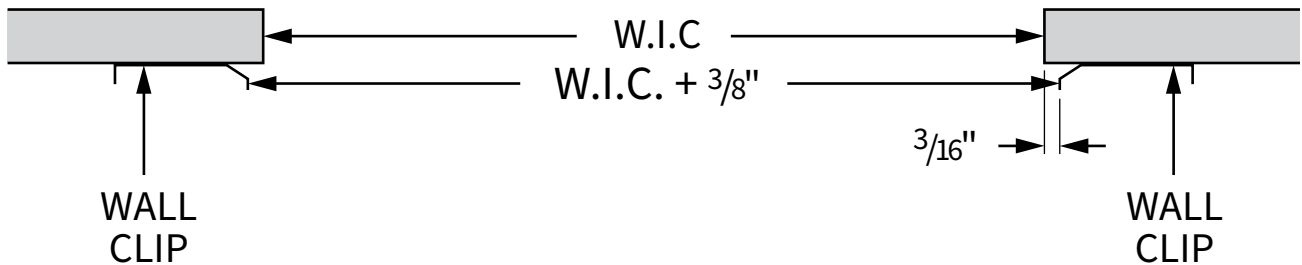

Figure 5: Wall Clip Position

Face Frame Installation

NOTE

Note determine if the floor is level. If the floor is not level, install the wall clip on the high side of the opening.

1. Attach the wall clip to the wall through the holes provided. Be sure that the clip is plumb. This is critical for proper photoeye operation (Page 7, Figures 3 & 5). Photoeyes are pre-mounted in face frames at factory. It is important that the transmitter and receiver are aligned for proper door operation. Make sure the photoeyes are located in-line with each other. Shimming of the wall clip & header assembly may be required to compensate for non-parallel walls.
2. Route photoeye cables on back of header and through the grommetted keyholes on the bottom edge of the header (Figure 6).
3. Mount header to the wall. (Make sure the projection tabs on the top of the side frames go into the notches on the bottom of the header.)

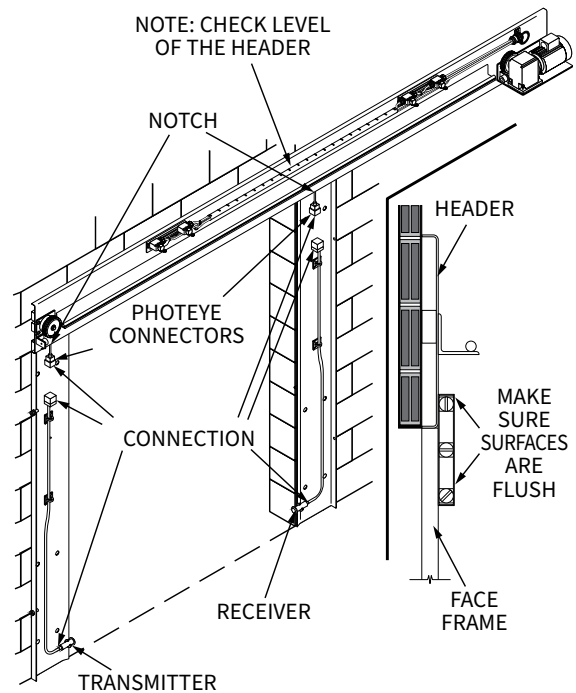

Figure 6: Installing Wall Clips to Opening

⚠ DANGER

DANGER keep personnel out of the area below the header until the rail is secured to the wall. Failure to do so could result in property damage, personal injury or death.

4. Install the face frame cover to the clip and secure with two screws provided (Figure 6).

NOTE

Note the surface of the face frame should match the surface of the header. If not, it will be necessary to shim the clip away from the wall so the two surfaces meet. This is necessary to provide the proper seal for the gaskets.

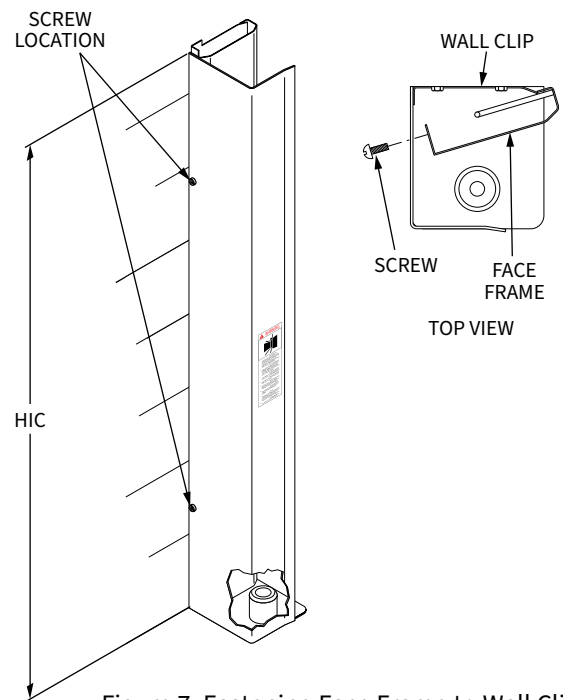

Figure 7: Fastening Face Frame to Wall Clip

NOTE

Note recheck wall clips to be sure they are plumb and level. Make any necessary adjustments.

Initial Electrical Connections

⚠ DANGER

DANGER control box contains HIGH VOLTAGE! The following procedures should be performed by qualified electrical personnel only. Wiring must meet all local, state, federal and international or other governing agency codes. Failure to do so could result in serious injury or death.

NOTE

Note to prevent damage or injury to personnel and machinery, operator and controls must be grounded.

Note wiring must be completed by a licensed electrician. All wiring connections must be in accordance with all local, state, federal, NEC or other governing agency codes. Reference electrical drawings shipped with door.

⚠ CAUTION

Caution run conduit and cables into bottom or side of the control box only! Drilling through the top of the control box will void the warranty.

Caution protect and cover all electrical components inside control panel prior to drilling enclosure. Failure to do so may result in component malfunctions.

⚠ DANGER

DANGER control box contains HIGH VOLTAGE! The following procedures should be performed by qualified electrical personnel only. Wiring must meet all local, state, federal and international or other governing agency codes. Failure to do so could result in serious injury or death.

1. Mount control panel and run power to the enclosure and motor following the procedure listed below. A fused disconnect is required for each ASI door as a means of disconnecting incoming power to the control box. This disconnect is normally supplied by others unless specifically ordered from ASI

Doors Inc.

- a. Turn off power to the power source.
 - b. Make sure it has the proper voltage.
 - c. Open control box cover by removing cover screws.
 - d. Connect control box wires as follows:
By unscrewing terminal screw and inserting wire then retightening terminal screw once wire is in place...
 - i. ...connect hot wire to terminal L1.
 - ii. ...connect neutral wire to terminal N.
 - iii. ...connect ground wire to terminal GND.
 - iv. ...connect motor lead T1 to terminal T1.
 - v. ...connect motor lead T2 to terminal T2.
 - vi. ...connect motor lead T3 to terminal T3.
 - e. Open electrical box on motor by unscrewing electrical box screws.
 - f. Connect motor wires as follows:
By unscrewing wire nut and inserting wire then retightening wire nut when wire is in place...
 - i. ...connect T1 wire from control enclosure to T1 wires in motor electrical box.
 - ii. ...connect T2 wire from control enclosure to T2 wires in motor electrical box.
 - iii. ...connect T3 wire from control enclosure to T3 wires in motor electrical box.
 - g. Connect fire detection device wires as follows:
By unscrewing terminal screw and inserting wire then retightening terminal screw once wire is in place...
 - i. ...connect L+ wire from control enclosure to fire signal device.
 - ii. ...connect 66 wire from control enclosure to other side of fire signal device.
2. Connect the photoeyes in the side frame to the photoeye cables coming out of the bottom of the header. Use a cable tie to connect the 2 cables (Figure 6).
 3. Attach side frame covers to the wall clips.
 4. Test photoeyes by making sure input light goes out when the beam is broken.

Panel Installation

1. Remove the guide roller mounted at the base of the trailing edge face frame (Figure 7). With roller truck positioned in the center of the rail, slide the panel between the shroud support and roller truck. Lift panel over the roller mount at the base of the trailing edge face frame. Secure door panel to the roller truck with two vertical panel adjustment bolts ($1/2''-13 \times 3''$). Install four roller truck locking bolts ($3/8''-16 \times 3/4''$). Tighten roller locking truck bolts all the way down and then back them off one full turn (Figures 8 & 9).
2. After backing off roller truck bolts, adjust the two vertical adjustment bolts to position the panel at the desired height. The panel gasket should have contact with floor for proper sealing. Tighten the locking nuts to maintain height adjustment (Figure 9).
3. Tighten the four $3/8''-16 \times 3/4''$ long roller truck locking bolts to secure the door panel to the roller truck.
4. Reinstall the guide roller at the base of the trailing edge face frame. Do not tighten at this time.
5. Connect plug from reversing edge on the door panel to its matching receptacle on the upper truck. Use supplied tie wrap to keep connectors from separating and secure to upper truck with supplied screw (Figure 9).

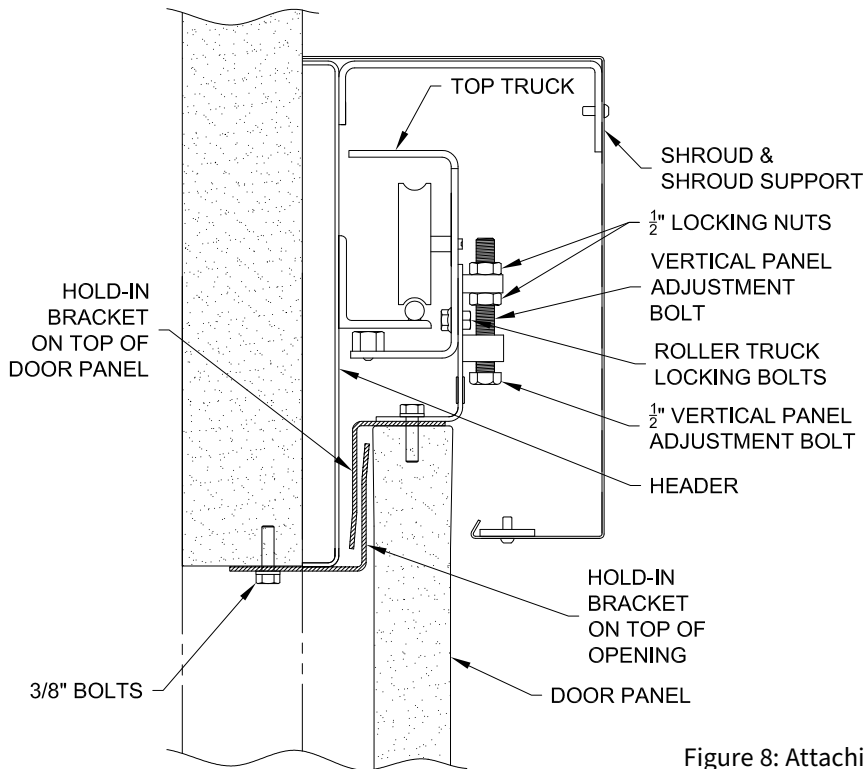

Figure 8: Attaching Panel to Header

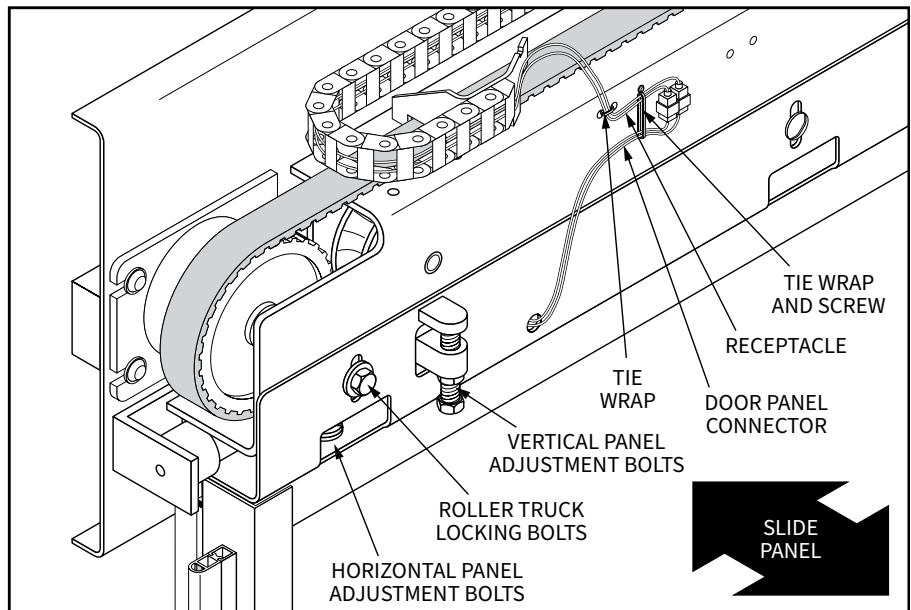

Figure 9: Adjusting Bolt Locations

Panel Installation Continued

6. Move door panel to closed position. Center door panel on lower truck by loosening horizontal panel adjustment bolts, moving the bolts to the middle of their slots and tightening them down (Page 10, Figures 8 & 9). At this time, hold-in brackets on door panel should also be adjusted so their screws are in the centers of their slots.
7. Note photoeye clearance holes when installing trailing edge hold-in bracket.
8. Manually move door to ensure it slides freely. Install top and side hold-in brackets in the door opening (Figures 10, 11, & 12). Faces of jambs need to be solid enough to support installing hold-in brackets. If not, add capping or other support to the opening.
9. Position hold-in brackets such that the bent lip of the bracket sits between the door panel and its hold-in brackets (Figures 8, 11, & 12).
10. Manually move door to ensure it slides freely. Adjust position of hold-in brackets as needed. Tighten hold-in bracket mounting screws (Figure 10).

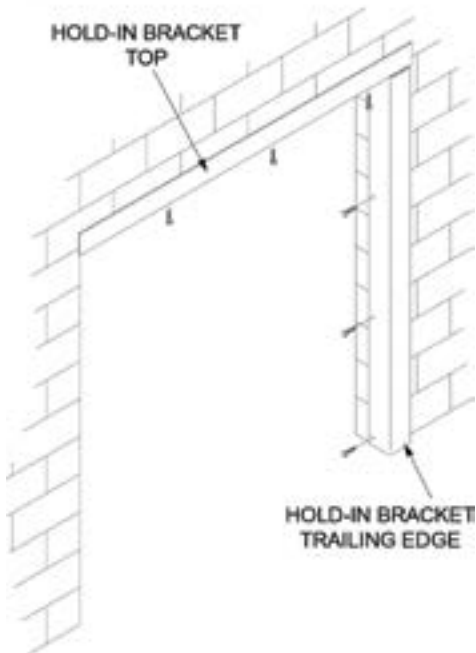

Figure 10: Gasket Retainer/Hold-In Bracket Assembly

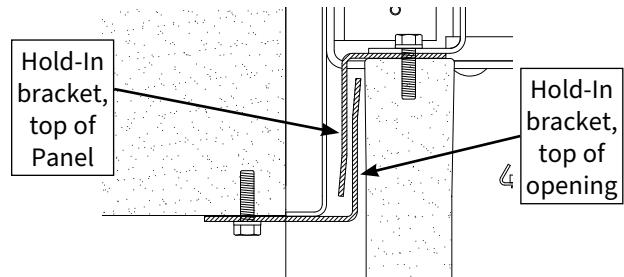

Figure 11: Hold-In Brackets, Top of Opening

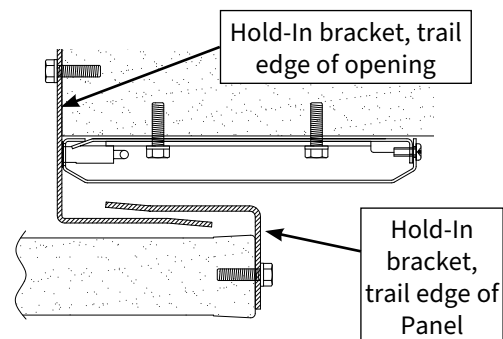

Figure 12: Hold-In Brackets, Trail Edge of Panel

Shroud Installation

1. Install top shroud halves and bottom splice plate (Figure 13).
2. Caulk all joints and seams.

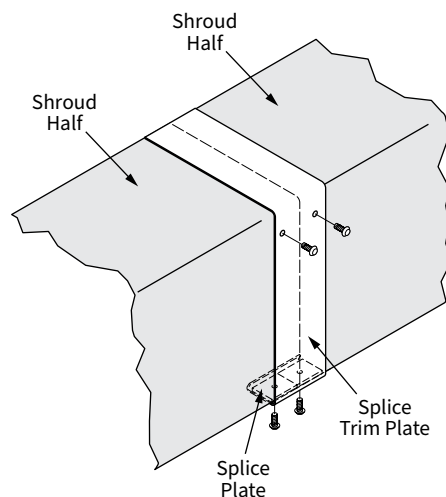

Figure 13: Shroud Splice Plate

Panel Adjustment

1. Position the door in the closed position. Loosen the two horizontal panel adjusting bolts securing the door panel to the lower roller truck (Figures 8 & 9). Loosen all screws securing trailing edge hold-in bracket to door panel.

NOTE

Note minimal contact is all that is necessary to provide a tight seal. This will also extend the life of the gasket.

2. Slide hold-in brackets on top and trailing edge of door panels in or out such that these brackets are between the hold-in bracket assemblies and the header or the trailing edge face frame (Figure 11 & 12).
3. Tighten the four horizontal panel adjustment bolts securing the door panel to the lower truck. Tighten all screws on trailing edge of the door panel securing the hold-in bracket to the door panel.
4. Manually operate the door and visually inspect to ensure the gasket is making contact around the perimeter of the opening. Equally adjust guide roller to maintain a seal along the trailing edge face frame (Figure 14). Make any adjustments necessary for a tight seal.
5. Add or remove shims (washers) located behind the nylon guide to adjust the desired “pull-in” on the leading edge of panel (Figure 15). More shims will increase the amount that the gasket will contact the face frame resulting in a tighter seal. It should also be noted that increased gasket pressure will reduce the gasket life and make it more difficult to manually open the door.

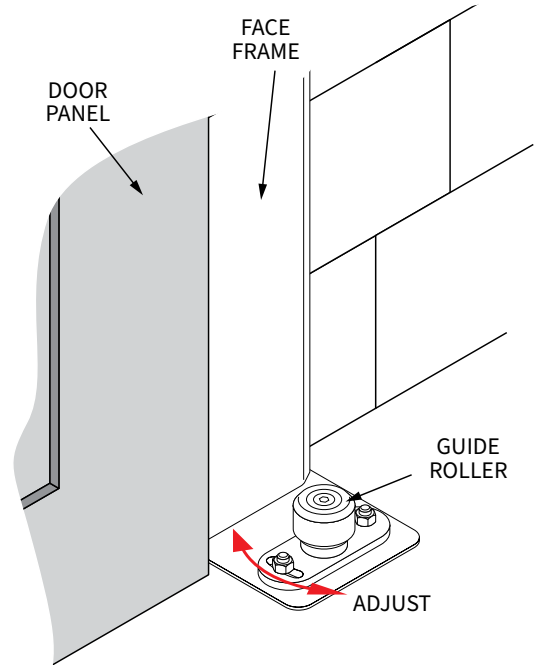

Figure 14: Adjusting Panel to Engage Gasket

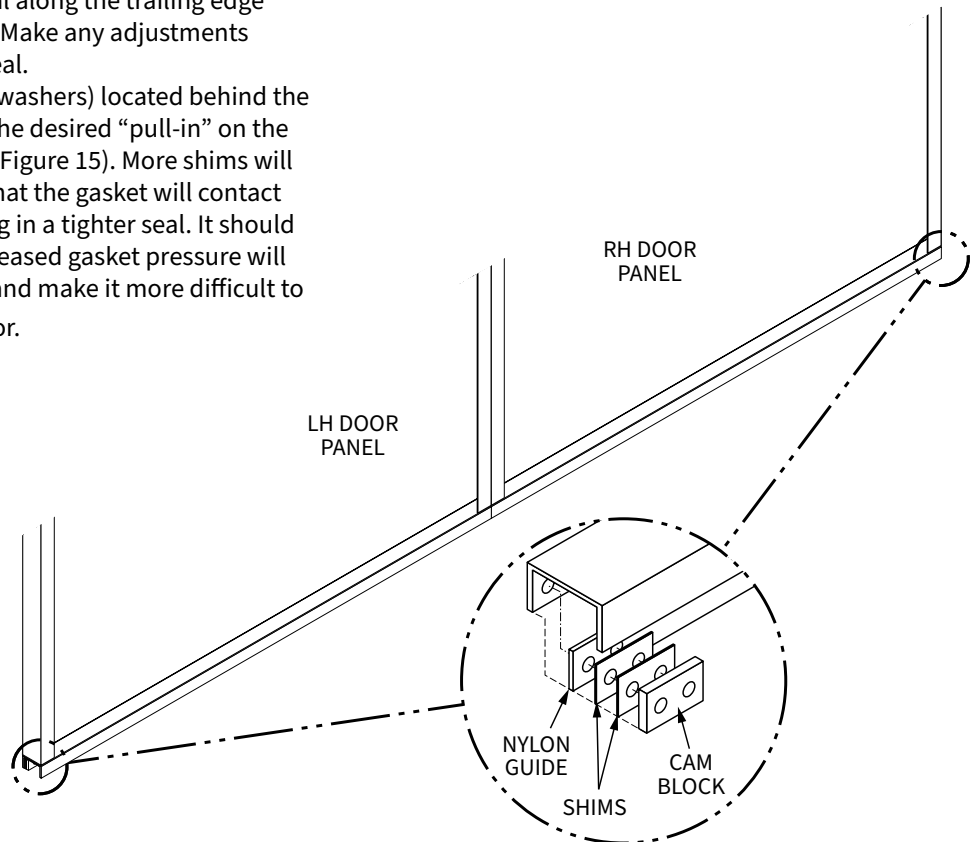

Figure 15: Shim Location

Electrical Controls



DANGER control box contains HIGH VOLTAGE! The following procedures should be performed by qualified electrical personnel only. Wiring must meet all local, state, federal and international, or other governing agency codes. Failure to do so could result in serious injury or death.

The PLC (Programmable Logic Controller) control system is designed specifically for ASI Doors. The PLC's programmed self-diagnostic features convey both door status and troubleshooting indicators through individual LED's. Additional inputs are available for a Reversing Edge and Reversing Photoeyes. Troubleshooting time is significantly reduced since the LED indicator lights direct you to specific problems. Initial electrical hookup is made easy with conveniently located plug-in type connectors. Individual timers for automatic Time to Close and Partial Opening offer flexibility of adjustment for existing or future applications. Special features include a non-resettable counter that can be used to establish periodic maintenance programs.

INPUT POWER

The nominal supply voltage for the control panel is typically 120 VAC. A backup power supply is required and may be purchased optionally from ASI, Doors, Inc. Be sure to verify this voltage prior to supplying power to the control panel. The control circuit includes both 120 VAC (for the PLC) and 24 VAC (for other sensing and electrical) devices.

INSTALLATION



Figure 16: PLC

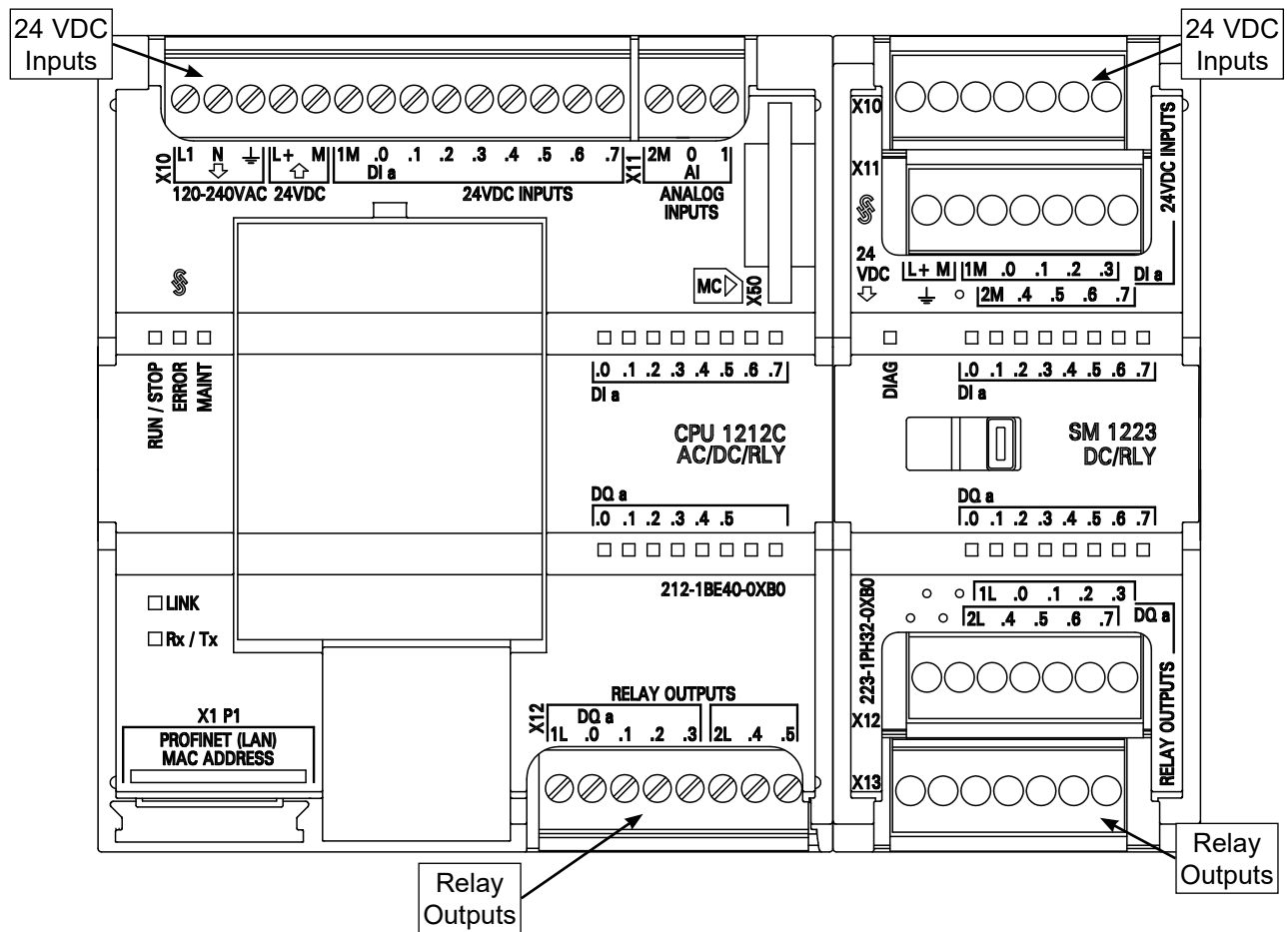

Figure 17: Electrical Connections

- PLC Fault:** Indicates a system fault has occurred. Try to recycle power to clear (by leaving power off several minutes before applying power to control). If this fault does not clear, call ASI service.
- Run Mode:** Indicates the PLC is in Run Mode, which is required to operate. If this LED is not lit, position the dip switch to Run Mode (top position). If PLC does not go into Run Mode, call ASI service.
- Stop Mode:** Indicates the PLC is in Stop Mode, which disables PLC operation.
- Term Mode:** Indicates the PLC is in Terminal Mode. This is used when the PLC is connected to a personal computer or other interface device.
- EEPROM Socket:** This is used to load the PLC program. The PLC is shipped with a blank module since the PLC stores the program into memory.
- Communications Port:** This is used to connect the PLC to a personal computer or other programming device.
- Output LED's:** Indicates the status of each PLC output.
- Input LED's:** Indicates the status of each PLC input.
- Pots 0 and 1:** These adjustable potentiometers are used for adjusting the time to close and partial open functions. The pots are located under an access cover on the right of the PLC.

PLC Inputs

(14) 24V DC inputs are located on the right section of the PLC. The first bank of (8) inputs are designated as I0.0 – I0.7 and the second bank of (8) inputs are designated as I1.0 – I1.7. To signal a particular input, the input common (L+) circuit is connected to the input.

ACTIVATOR INPUTS

Input I0.0 – OPEN: This input is connected to a normally open pushbutton or other momentary contact that, when activated, causes the door to open.

Input I0.1 – CLOSE: This input is connected to a normally open pushbutton or other momentary contact that, when activated, causes the door to close. **NOTE:** This signal is ignored if the door is opening.

Input I0.2 – OPEN/CLOSE: This input is connected to a normally open pushbutton or other momentary contact that signals the door to open or close dependent on door position.

Input I0.3 – PARTIAL OPEN: This input is connected to a normally open pushbutton or other momentary contact that, when activated, causes the door to open short of fully open. See the “Other Electrical Functions” section for adjustment instructions.

Input I0.4 – E-STOP: This input is connected to a closed contact or pushbutton that removes the signal causing the door to stop. The door will not operate until this signal is made.

LIMIT INPUTS

Input I0.5 – OPEN LIMIT: This input is connected to a normally closed limit switch that, when activated, initiates the door to stop opening. The indicator light will be off when the door is fully open.

Input I0.6 – CLOSE LIMIT: This input is connected to a normally closed limit switch that, when activated, initiates the door to stop closing. The indicator light will be off when the door is fully closed.

Input I0.7 – PROGRAMMABLE: This input is not typically programmed. If your control utilizes this input, additional instructions will be sent with the door.

1. If a device is wired across L+ and 61, it will cause the door to reverse (open), unless the door is on the closed limit.
2. If the door has dual photoeyes, remove the jumper between (11) and (12) on the amplifier base.
3. If the door is interlocked, remove the jumper between L+ and 63 and wire in the interlock contact.

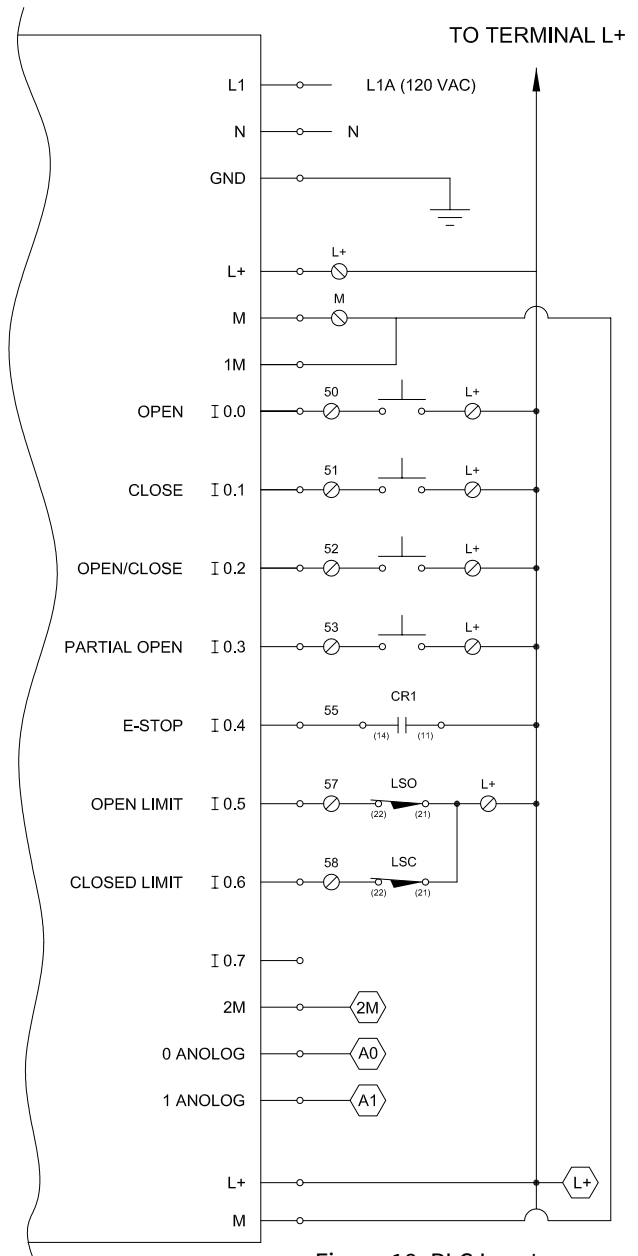

Figure 18: PLC Inputs

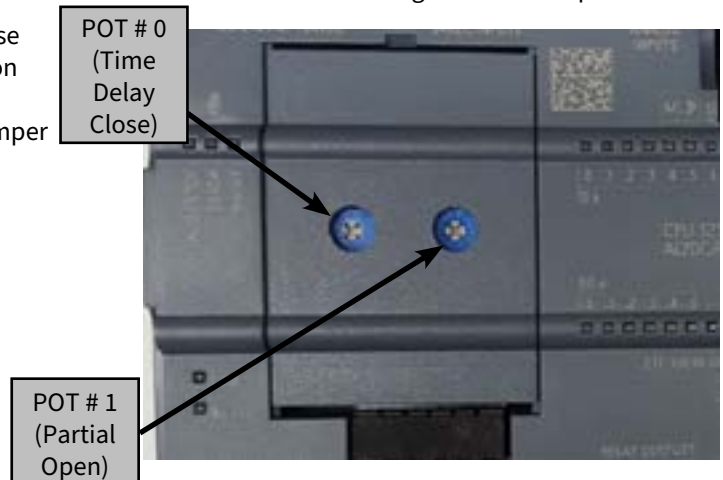

Figure 19: PLC Cover

ADDITIONAL INPUTS

Input I1.0 – OPEN SLOW: Input for Slow Open mode.

Input I1.1 – CLOSE SLOW: Input for Slow Close mode.

Input I1.2 – REVERSING EDGE: This input is connected to a normally closed switch. If the signal is interrupted at any time while the door is closing, the door will instantly reverse and open. This input has no effect if the door is fully closed or opening. NOTE: The contact from CR2 is normally open – held closed and opens if reversing edge is impacted.

Input I1.3 – REVERSING PHOTOEYE: This input is connected to a normally closed switch. If this signal is broken while the door is closing, the door will reverse and fully open. NOTE: ASI supplied photoeyes must be set to light operate mode and wired to normally open contacts that are held closed when the light beam is made. When the light beam is blocked, the contact switches state to open. If your door was specifically ordered without a photoeye, this input must be jumpered out by connecting a wire between terminals 61 and 62 (Input I1.1 of the PLC). If additional devices are added to function as described, wire normally closed contacts in series between terminals L+ and 61.

Input I1.4 – EXTERNAL CUTOUT: This input is connected to a normally closed switch. When this signal is broken the door will not operate. This input can be used to interlock this door with other doors, conveyors, security system, etc.

Inputs I1.5 – PROGRAMMABLE: This input is not typically programmed. If your control utilizes this input, additional instructions will be sent with the door.

Inputs I1.6 – FIRE SIGNAL RESET: This input is connected to a normally open switch. When this switch is closed, the door will return to normal operation.

Inputs I1.7 – FIRE SIGNAL: This input is connected to a fire detection device. When L+ to 66 is closed, the unit will operate in a normal cycle mode. When L+ to 66 is open, the unit will operate in a fire detection mode. Once a fire signal has been received, the unit will remain in the fire detection mode until a “Fire Signal Reset” has been received.

L+ – COMMON TERMINALS: Several input common terminals are provided for convenient wiring on the terminal strip of the control panel.

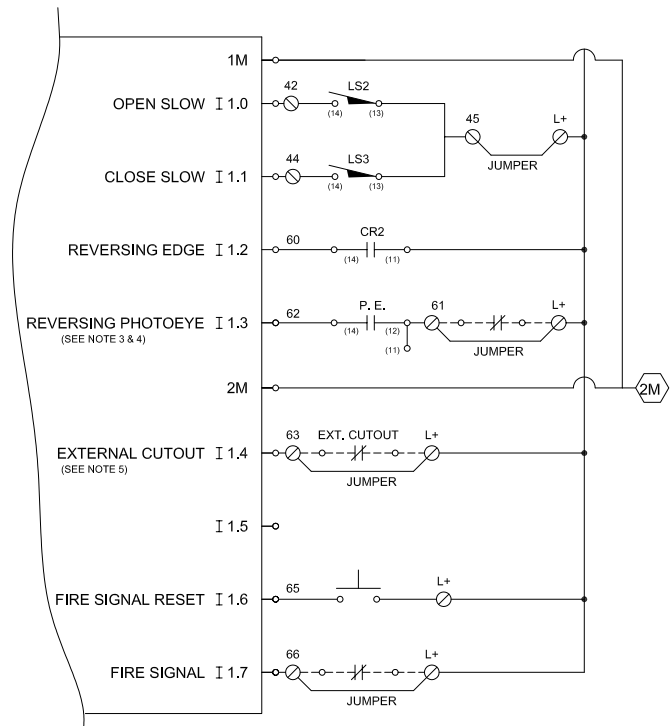

Figure 20: Additional Inputs

1. If a device is wired across L+ and 61, it will cause the door to reverse (open), unless the door is on the closed limit.
2. If the door has dual photoeyes, remove the jumper between (11) and (12) on the amplifier base.
3. If the door is interlocked, remove the jumper between L+ and 63 and wire in the interlock contact.

PLC Outputs

(10) Relay outputs are located at the upper section of the control. These terminals are used to provide signals to the VFD (Variable Frequency Drive) to operate the motor, provide door position signals, and provide door fault indicators.

INDICATOR OUTPUTS

Output Q0.0 – DOOR CLOSED: This output relay closes when the door is in the fully closed position. The LED of the output will be lit when the door is fully closed.

Output Q0.1 – DOOR OPEN: This output relay closes when the door is in the fully open position. The LED of the output will be lit when the door is fully open.

Output Q0.2 – DOOR CLOSING: This output relay closes when the door is closing. The LED of the output will be lit when the door is closing.

Output Q0.4 – FIRE SIGNAL: This output relay closes when a fire signal is made. The LED of the output will be lit when a fire signal is made.

VFD CONTROL OUTPUTS

Output Q1.1 – OPEN: This output relay closes to signal the VFD to open the door.

Output Q1.2 – CLOSE: This output relay closes to signal the VFD to close the door.

Output Q1.0 & Q1.3 – SLOW SPEED: These outputs are used for Slow Speed Open & Close modes.

OTHER OUTPUTS

Output Q1.4 – FAULT: This output flashes in different sequences to indicate a door fault. These faults are shown in the following table.

Output Q1.5 – COUNTER: This output relay is connected to a mechanical non-resettable counter to be used for maintenance.

Output Q1.6 – BOLT LOCK: This output relay is used with the optional bolt lock.

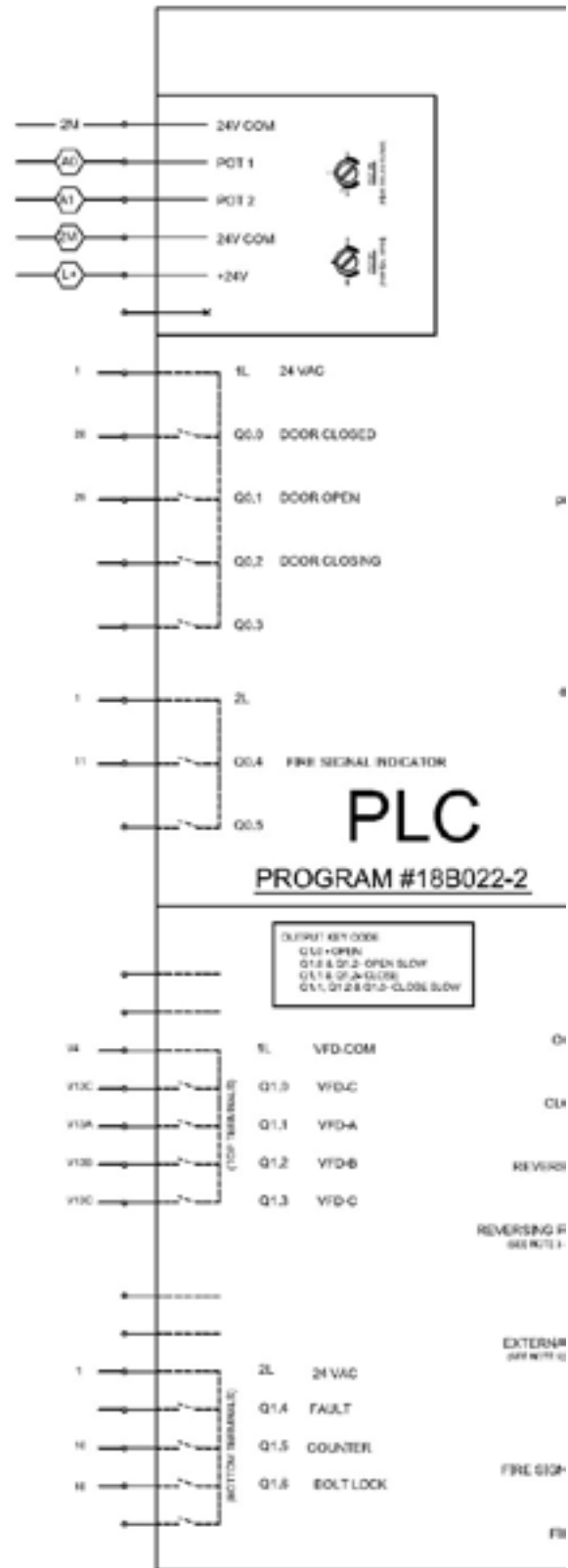

Figure 21: PLC Outputs

Other Electrical Functions

Fault Condition	LED Sequence	Fault Cause	Action to Clear Fault
Motor Run Timer	One quick flash every 4 seconds	The motor ran continuously for greater than 10 seconds.	Correct problem, then cycle Power off and on or cycle E-Stop off and on.
Start-Up Fault	Two quick flashes every 4 seconds	PLC receives open, close, open/close, partial open, reversing edge or reversing photoeye signal at power up.	Correct problem, then cycle Power off and on or cycle E-Stop off and on.
E-Stop Fault	Two quick flashes every 4 seconds	Open, close, open/close, partial open, reversing edge or reversing photoeye signal coming out of E-Stop.	Correct problem, then cycle Power off and on or cycle E-Stop off and on.
Double Limits	Three quick flashes every 4 seconds	Both limit input signals are off. Door is on two limits at the same time.	Correct problem, then cycle Power off and on or cycle E-Stop off and on.

TIME TO CLOSE: This is a rotary pot (pot 0) used to set a 2–20 second timer. The Time To Close function signals the door to close automatically after a preset amount of time when the door is open. This function can be enabled or disabled. Adjusting this pot with a small screwdriver on the PLC completely counterclockwise will disable this timer. Adjusting the pot more than 10% clockwise will enable the timer. This timer can be typically adjusted from 2 to 20 seconds. Rotating 10% clockwise will set the timer to 2 seconds, 50% clockwise will set the timer to 10 seconds, and fully clockwise will set the timer to 20 seconds.

The Time To Close timer begins when the door reaches the open limit and the activating pushbutton or contact has been released and the reversing photoeyes (when used) are not detecting any obstacles. The timer will reset whenever the PLC receives a signal from an open or partial open input or when a signal is removed from a reversing photoeye, reversing edge or stop input.

PARTIAL OPEN: This feature can be used when the user desires to have the door open to a partial open position in addition to fully opening the door. By using the PLC's input I0.3 with the rotary pot (pot 1), this feature allows the user to partially open the door. All partial open devices must be wired to input I0.3 while full open devices must be wired to inputs I0.0 or I0.2. The distance the door travels before stopping can be adjusted by rotating the pot 1 with a small screwdriver on the PLC. Adjusting the pot clockwise will allow the door to travel greater in the open direction while adjusting the pot 1 counterclockwise will reduce the distance the door travels in the open direction.

Note: All other door functions remain the same while using this feature.

MOTOR RUN TIME: To prevent damage to the door, a timer has been programmed into the PLC to stop the motor after a preset run time has been exceeded. This timer protects the motor by monitoring the run time and turns the motor off and signals a fault when it exceeds the preset time. After determining and correcting the cause of the Motor Run Time fault, the control must be reset by removing and reapplying supply power to the control panel. Examples of problems include a faulty limit switch or door binding.

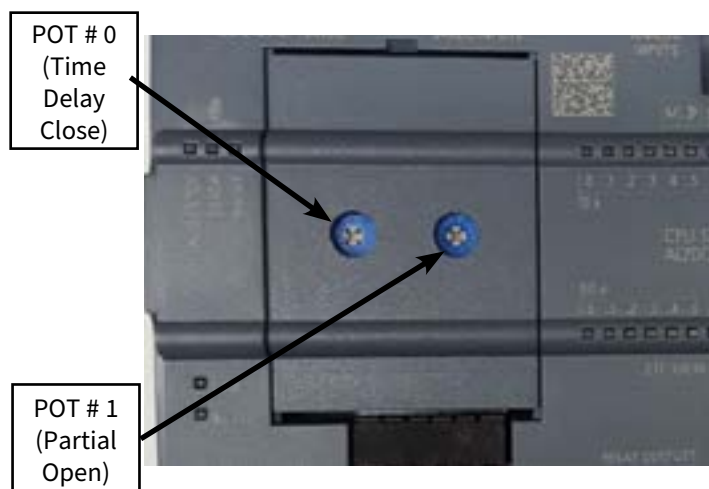

Figure 22: PLC Cover

Start-Up

⚠ WARNING

WARNING read and understand the start-up procedure in this manual before attempting to power-up the door. Failure to do so could result in death or serious injury and may result in property damage and will nullify all warranties.

NOTE

Note all limit switches, photoeyes and reversing edges have been tested at the factory and require no field wiring.

1. Position the door at the center of the rail.
2. With the power "OFF", manually operate the door to the fully open and fully closed positions and verify the limit switches activate as the cam passes by. Confirm that the switches are being tripped by the cam (Figures 23 & 24).

⚠ DANGER

DANGER disconnect power at the fused disconnect during all electrical or mechanical service. Disconnect must be properly locked out during maintenance or service of equipment. Failure to disconnect power could result in serious injury or death.

3. Position the door at the center of the opening. The variable frequency drive has been programmed at the factory and is not adjustable.
4. Turn on power to control panel and wait 10 seconds. Supply any activation signal, press reversing edge, block a photoeye or supply any reversing signal. The door should open. If the door starts to close, shut the power off immediately.

Check the wiring in the conduit box to the control panel to make sure that the wiring configuration is correct, i.e.: T1 to T1, T2 to T2, T3 to T3. The door should accelerate to full speed until it trips the first limit switch. It should decelerate and stop when it trips the final limit switch. The door will close automatically and will decelerate and stop in the closed position.

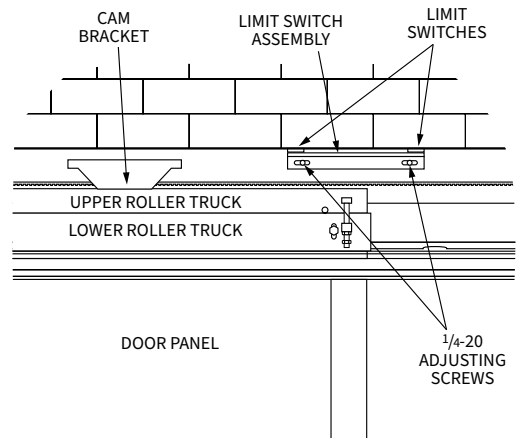

Figure 23: Adjusting Limits

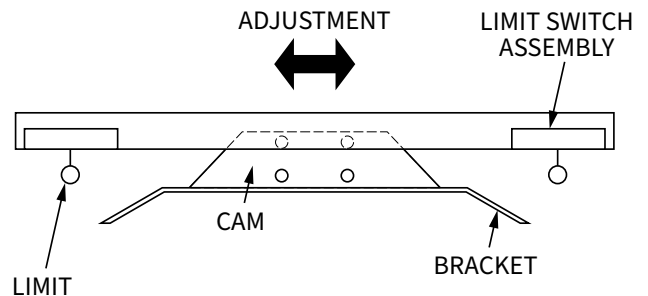

Figure 24: Adjusting Limits (Top View)

NOTE

Note the photoeye amplifier is preset at the factory and requires no in-field adjustments!

5. To verify that photoeyes (if equipped) are aligned properly, make sure door opening is clear of obstructions and photoeye beam is not blocked. Next check amplifier located in control panel and make sure red light is illuminated. If this light is off, photoeyes are not in alignment and door will not operate properly.
6. The limits have been set short at the factory. Adjust the limits for the final position of the door. Adjusting for the closed position: Moving the left limit switch assembly to the left will allow more door travel to the left for a R.H. door panel. (The opposite would apply for a L.H. door.) The door will stop prior to reaching the fully closed position or stop. Slide switch assembly as needed for final door panel positioning. Tighten two 1/4 – 20 screws on switch assembly (Figures 23 & 24).
7. Test the reversing edge on the active door panel while the door closes by pushing on the rubber profile (Figure 25). The door should stop and reverse when the edge is activated during the closing cycle.
8. If the door is equipped with photoeyes, test photoeyes by blocking the light beam. The door should open and remain open until the obstruction has been removed, the door will automatically close if time delay is set and times out. Cycle the door several times to verify correct operation by all activators, safety devices, and proper seal of the gasket. Make any necessary adjustments.
9. Install top shroud.
10. Caulk all joints and seams.

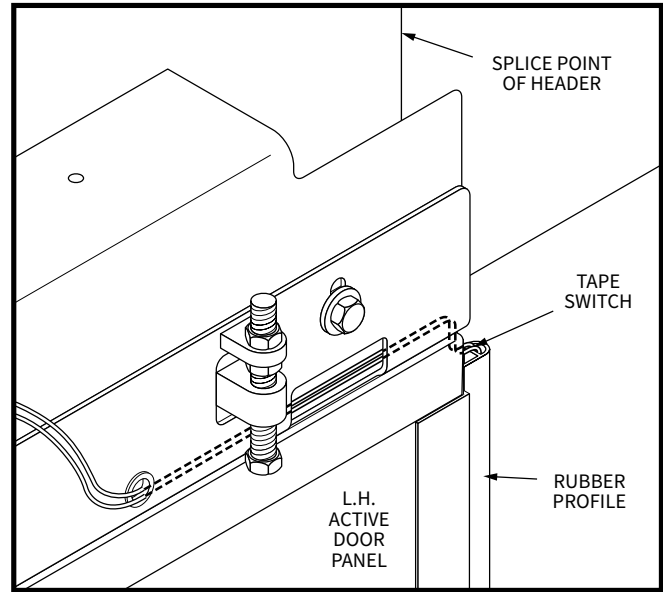

Figure 25: Testing The Reversing Edge

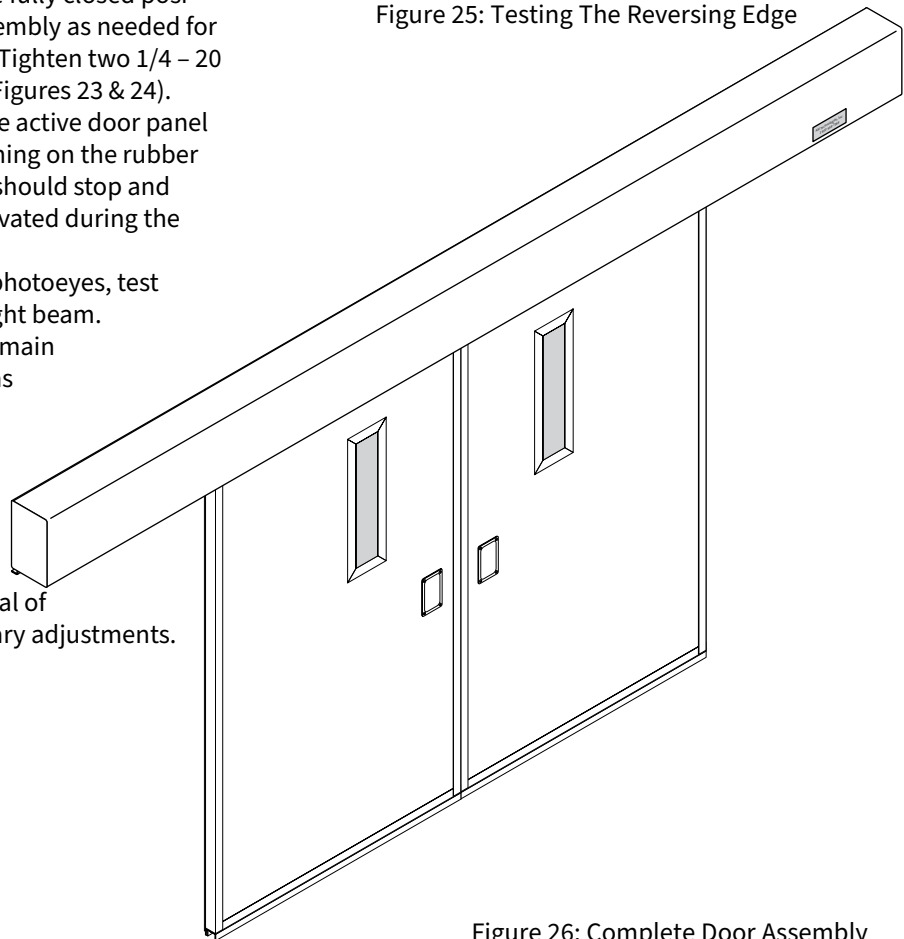

Figure 26: Complete Door Assembly

Inspection

1. **CHECK THE CONDITION OF THE MAIN ROLLER WHEELS.** Replace if the flange is $\frac{1}{16}$ " thick or less, and if the roller has excessive foreign debris on the working surface (Figure 33).
2. **CHECK GASKETS FOR PROPER SEALING.** Look for gasket compression along the entire door perimeter.
3. **CHECK MAIN DRIVE BELT FOR TENSION.** Allow a maximum deflection per chart (Figure 34) on one leg of the belt. Apply weight to belt & check deflection. If the tension is too loose, loosen and adjust the idler pulley bracket to maintain the desired tension. Once the proper tension is set, retighten the idler pulley bracket.
4. **CHECK OPERATOR MOUNTING BOLTS AND IDLER PULLEY BRACKET BOLTS FOR PROPER TIGHTNESS.** During the initial run in period these items may loosen.

Preventative

DAILY

1. Inspect all safety devices and check for proper operation. (Includes reversing edge and reversing photoeye(s).)



DANGER check all safety devices for proper operation daily. If any device is not operating properly, remove door from service until device is replaced or repaired. Failure to do so could result in property damage, serious injury, or death.

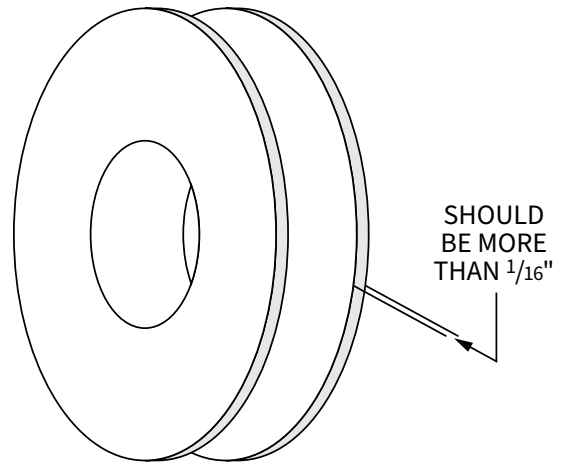

Figure 27: Roller Wheel Inspection

MONTHLY

1. Check roller truck and panel mounting bolts.
2. Check operator mounting bolts.
3. Check idler pulley bracket mounting bolts.
4. Check for a tight door seal. Make adjustments as shown on Pages 12 of this manual.
5. Check gaskets for wear. Replace if torn or worn.
6. Check header mounting bolts and tighten where necessary.
7. Check drive belt tension.
8. Check wiring harness for loose or sagging wires annually or every 100,000 cycles.

ANNUALLY

1. Check drive belt for wear (sides and teeth).
2. Check reversing edge wiring inside moving cable carrier. Replace if the cover is worn or cracked.
3. Check limit switch mounting brackets. Tighten any loose screws.

Troubleshooting

	Category	Probable Cause	Corrective Measures
Power	Motoar will not start	<ul style="list-style-type: none"> No power. Overload relay tripped. Control circuit breaker tripped while stopping. Wired for wrong voltage. Both limit switches open. Loose or disconnected wire. Defective actuator. 	<ul style="list-style-type: none"> Check power switches, fuses & connections. Verify 3 phase voltage at operator. Push to reset. Reset – determine cause. Check transformer, motor & overload relay for proper wiring. Unit may have been provided with wrong supply voltage. Reset limit switches. Check wiring and connection. Check wiring and actuator with ohmmeter.
	Overload trips out	<ul style="list-style-type: none"> Door not adjusted properly. Limit switches not adjusted. Door impacts rubber bumpers. Improper overload size. Short in wiring. Defective motor contactor. 	<ul style="list-style-type: none"> Operate door manually – adjust for proper travel. Adjust all limit switches. Door panel should not drag along when moving. Compare overload to overload nameplate. The overload is set for average conditions at S.F. = 1.0. If necessary, adjust slightly higher. Check out wiring – a short may also have blown a fuse. Test as necessary – replace if required.
	Fuses blow	<ul style="list-style-type: none"> Short in control circuit 	<ul style="list-style-type: none"> Trace wiring – particularly to activators with ohmmeter.
	Inconsistent starting, stoping and reverse	<ul style="list-style-type: none"> Loose or poor connection 	<ul style="list-style-type: none"> Check connections in control circuit and in all plug in connections on thewiring harness.
	Reversing edge works on opening cycle instead of closing cycle	<ul style="list-style-type: none"> Phase sequence reversed 	<ul style="list-style-type: none"> Change any 2 of the 3 line leads. Readjust both limit switches. NOTE: The limit switches and wiring are set up at the factory for a definite phase sequence. If the installation instructions are followed, this condition should not occur.
	Door opens but will not close (Reference PLC status page 15-17)	<ul style="list-style-type: none"> Loose or broken wire Photoeye malfunction Reversing edge malfunction 	<ul style="list-style-type: none"> Disconnect reversing edge from wiring harness. Check for continuity with ohmmeter. Check cable inside the cable carrier. Realign photoeye, inspect wiring and amplifier, replace if necessary. Inspect wiring, replace if necessary.
	Door closes and opens immediatly	<ul style="list-style-type: none"> Reversing edge switch signaling to reopen 	<ul style="list-style-type: none"> Check for reversing edge pinching or hitting on door frame or obstruction. Check bumper stops, reversing edge positions and limit switch.
	Drive belt "slaps" bottom side of rail	<ul style="list-style-type: none"> Belt is loose 	<ul style="list-style-type: none"> Retension drive belt.
	Drive belt squeaks	<ul style="list-style-type: none"> Pulley misalignment 	<ul style="list-style-type: none"> Align idler pulley with pulley on operator.

Instructions for Ordering

This parts manual is intended to assist in the correct identification of the more commonly replaced parts; covering, generally, all models and styles offered within the marathon pharm. Line. The manual will also help identify obsolete parts, part design changes and current production parts. For more specific parts information, please contact an authorized representative or consult the factory's customer service or engineering departments. Asi doors reserves the right to discontinue any part and make design changes without notice.

General Instructions for Ordering Door Parts

Accurate information is always necessary to serve you correctly and promptly. Several steps should be followed to determine exactly the parts that are needed.

Refer to the information tag on your door and record the:

1. Door model number
2. Job number
3. Door number
4. Manufacturing date.

Use part numbers referenced in this manual.

If the item is not found in the manual, the product code on the back of the item is helpful.

If your door has no information label, the approximate purchase date is helpful.

Call
1-800-558-7068
or visit
asidoors.com/parts
to order parts

Door Identification

Determining the Job Number, Model and Year of Manufacture of your door is necessary to provide quick and accurate parts identification. The following is a description of labels and their locations.

When ordering parts, specify Job Number, Door Number and Manufacture Date

Product Labels:

Manual Doors

ASI Doors, Inc.		
MILWAUKEE	WISCONSIN	MADE IN USA
DOOR MODEL <input style="width: 100%;" type="text"/>	JOB NUMBER <input style="width: 100%;" type="text"/>	DOOR NUMBER <input style="width: 100%;" type="text"/>
MFG. DATE <input style="width: 100%;" type="text"/>	INSPECTED BY <input style="width: 100%;" type="text"/>	

Power Doors

ASI Doors, Inc.		
MILWAUKEE	WISCONSIN	MADE IN USA
DOOR MODEL <input style="width: 100%;" type="text"/>	JOB NUMBER <input style="width: 100%;" type="text"/>	DOOR NUMBER <input style="width: 100%;" type="text"/>
MFG. DATE <input style="width: 100%;" type="text"/>	INSPECTED BY <input style="width: 100%;" type="text"/>	
OPERATOR TYPE <input style="width: 100%;" type="text"/>	MODEL # <input style="width: 100%;" type="text"/>	WIRING DIAGRAM <input style="width: 100%;" type="text"/>
HORSEPOWER <input style="width: 100%;" type="text"/>	VOLTAGE/PHASE <input style="width: 100%;" type="text"/>	HZ AMPERAGE <input style="width: 100%;" type="text"/>

ID Tag Location

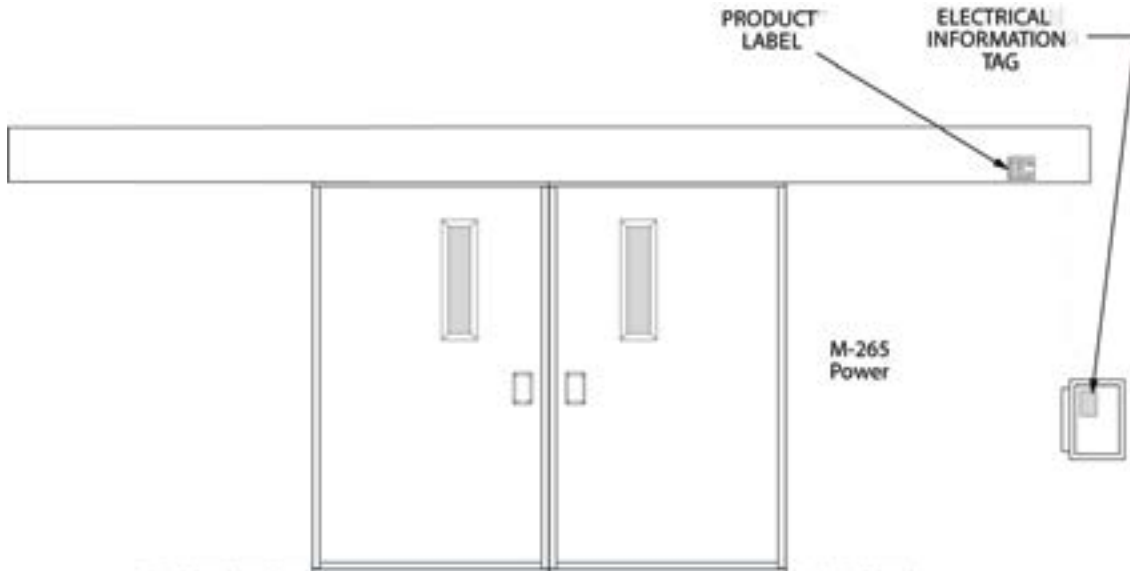

Door Assembly

When ordering parts, specify
Job Number, Door Number
and Manufacture Date

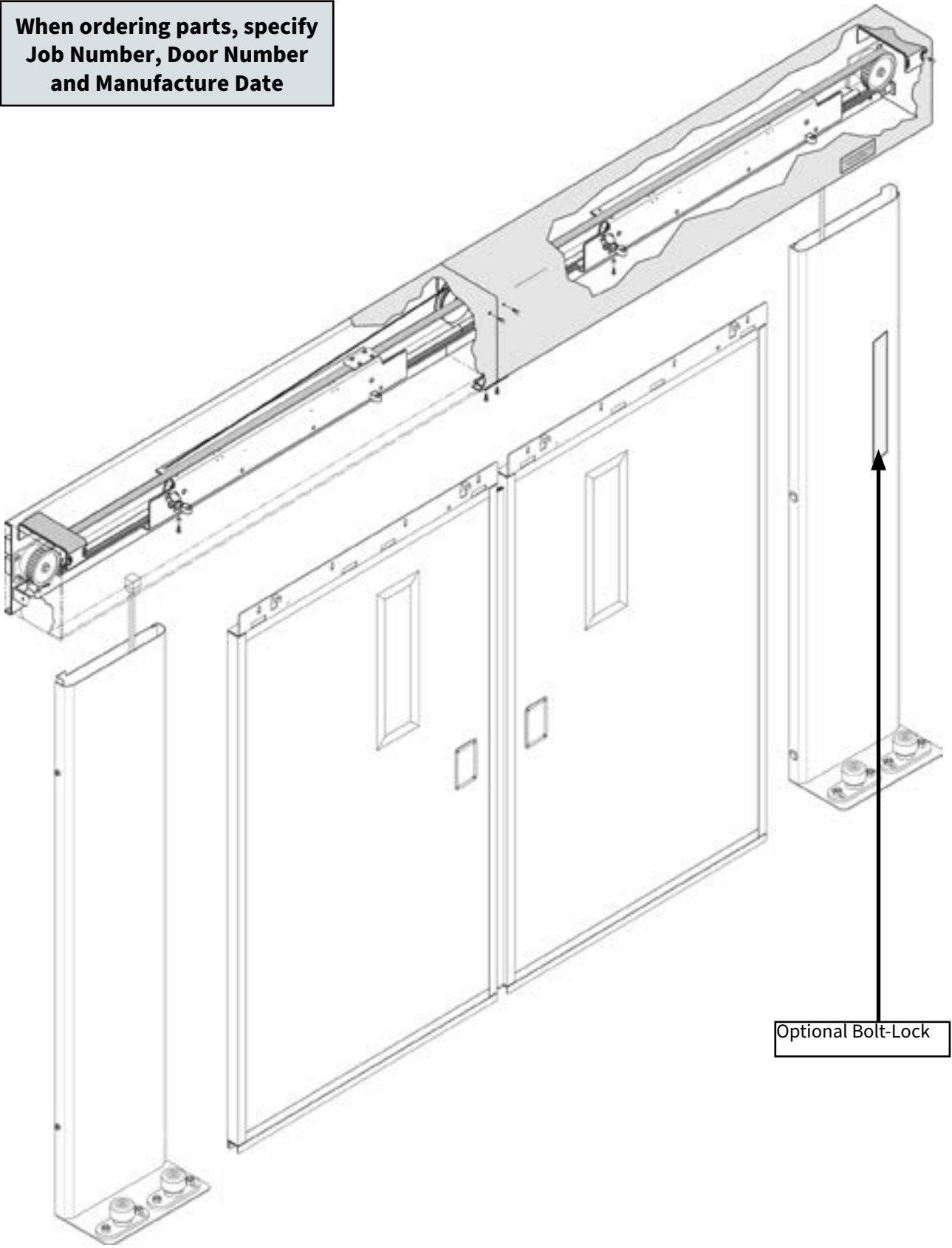

Optional Bolt-Lock

NOTE: Subsequent pages show detailed assemblies with parts lists.

REPLACEMENT
PARTS

Door Panel Assembly

86D431F1, Power, RH

86D431F2, Power, LH

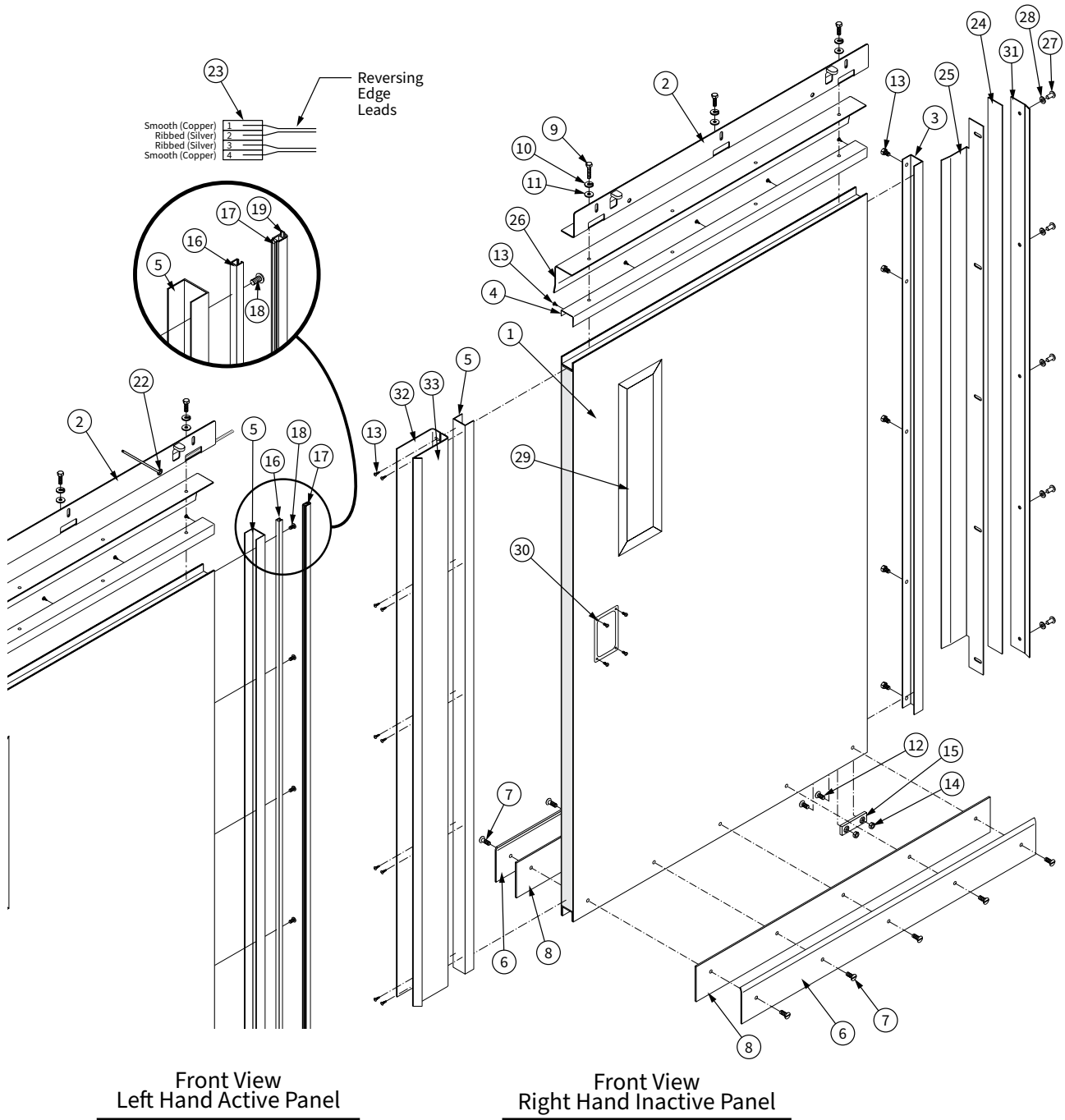

**When ordering parts, specify
Job Number, Door Number
and Manufacture Date**

REPLACEMENT PARTS

Door Panel Assembly Continued

86D431F1, Power, RH
86D431F2, Power, LH

Item	Part #	Description
1	32D525F1	Door fabrication, S/S, no window
-	32D525F2	Door fabrication, S/S, 4" x 25" window
-	32D525F3	Door fabrication, S/S, 10" x 10" window
-	32D525F4	Door fabrication, galvanized, no window
-	32D525F5	Door fabrication, galvanized, 4" x 25" window
-	Consult Factory	Door fabrication, galvanized, 10" x 10" window
-	28D161F4	Door fabrication, other specials
2	13C381F1	Weldment, roller truck, lower, fire
3	13C381F2	Capping, trailing edge, RH, inactive panel, S/S
-	13C381F2	Capping, trailing edge, RH, active panel, S/S
-	13C381F1	Capping, trailing edge, LH, inactive panel, S/S
-	13C424F1	Capping, top, S/S
4	13C424F2	Capping, top, galvanized
-	13D183F1	Capping, leading edge, RH, inactive panel, S/S
5	13D183F2	Capping, leading edge, LH, inactive panel, S/S
-	13D183F3	Capping, leading edge, RH, inactive panel, galvanized
-	13D183F4	Capping, leading edge, LH, inactive panel, galvanized
-	13D183F5	Capping, leading edge, RH, active panel, S/S
-	13D183F6	Capping, leading edge, LH, active panel, S/S
-	13D183F7	Capping, leading edge, RH, active panel, galvanized
-	13D183F8	Capping, leading edge, LH, active panel, galvanized
6	21B185F1	Retainer, sill gasket, S/S
-	21B185F2	Retainer, sill gasket, galvanized
7	41A466	Screw, 1/4"-20 x .63", PHL FHMS, S/S
8	15A019F3	Sill gasket, .045 x 41/4" x (WIC + 4.00)
9	41A719	Screw, 3/8"-16 x 2.25", F/T, HHCS, S/S
10	41A327	Washer, lock, 3/8", S/S
11	41A203	Washer, lock, 3/8", S/S
12	41A141	Screw, #10-24 x .50" PHL FHMS, S/S
12	41A618	Screw, #10-24 x .50" PHL PHMS, S/S
14	41A716	Nut, #10-24, hex, SS
15	14A198	Block, cam
16	11B100	Track, reversing edge, L = HIC + 3"
17	11B099	Extrusion, reversing edge, L = HIC + 3"
18	41A024	Screw, #8 x 3/4", FHSMS
19	24A011-s	Switch, tape, reversing edge, L = HIC - 3"
20	12B769F1	Shim, squaring, .06" x 1.88" x 96.00"
21	12B769F2	Shim, squaring, .13" x 1.88" x 96.00"
22	11A126	Grommet, rubber
23	22A202-2	Connector, 4 position, .156 MTA, red
24	15A019F1	Gasket, .045" x 2" x HIC
25	13C384F1	Bracket, hold-in, trailing edge, RH, S/S
-	13C384F2	Bracket, hold-in, trailing edge, LH, S/S
-	13C384F3	Bracket, hold-in, trailing edge, RH, galvanized
-	13C384F4	Bracket, hold-in, trailing edge, LH, galvanized
26	13C431F1	Bracket, hold-in, top, S/S
-	13C431F2	Bracket, hold-in, top, galvanized
27	41A149	Screw, 1/4"-20 x .625", SL THMS, S/S
28	41A195	Washer, flat, 1/4", standard, S/S
29	Consult Factory	Window
30	Consult Factory	Handle
31	13B786F1	Retainer, gasket, RH, S/S
-	13B786F2	Retainer, gasket, LH, S/S
32	13C429F1	Center, astragal, inner, S/S
-	13C429F2	Center, astragal, inner, galvanized
33	13C430F1	Center, astragal, outer, S/S
-	13C430F2	Center, astragal, outer, galvanized

When ordering parts, specify Job Number, Door Number and Manufacture Date

Face Frame Assemblies

76D404, Face Frame, RH, No Bolt Lock

76D0406, Face Frame, RH, With Bolt Lock

76D0408, Face Frame, LH

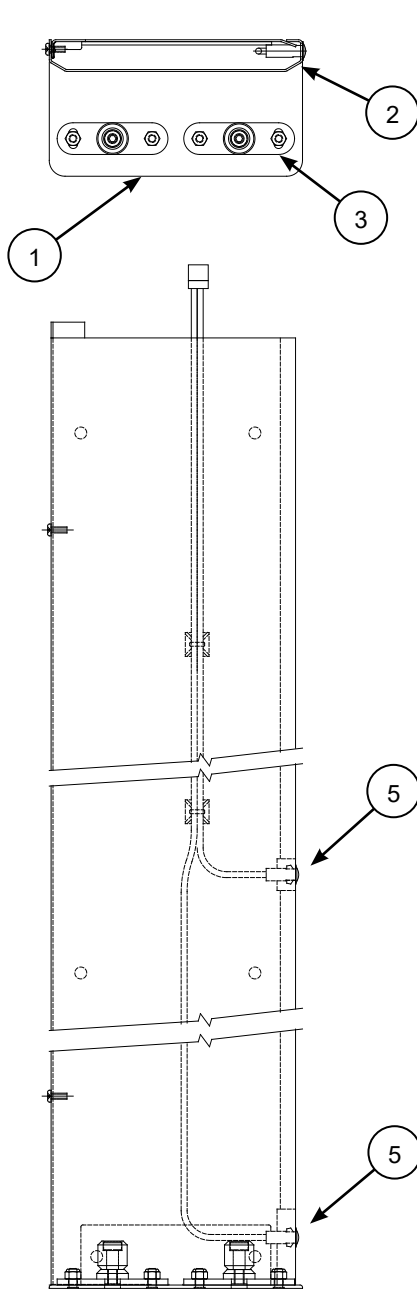

76D0408
BI-PART, LH

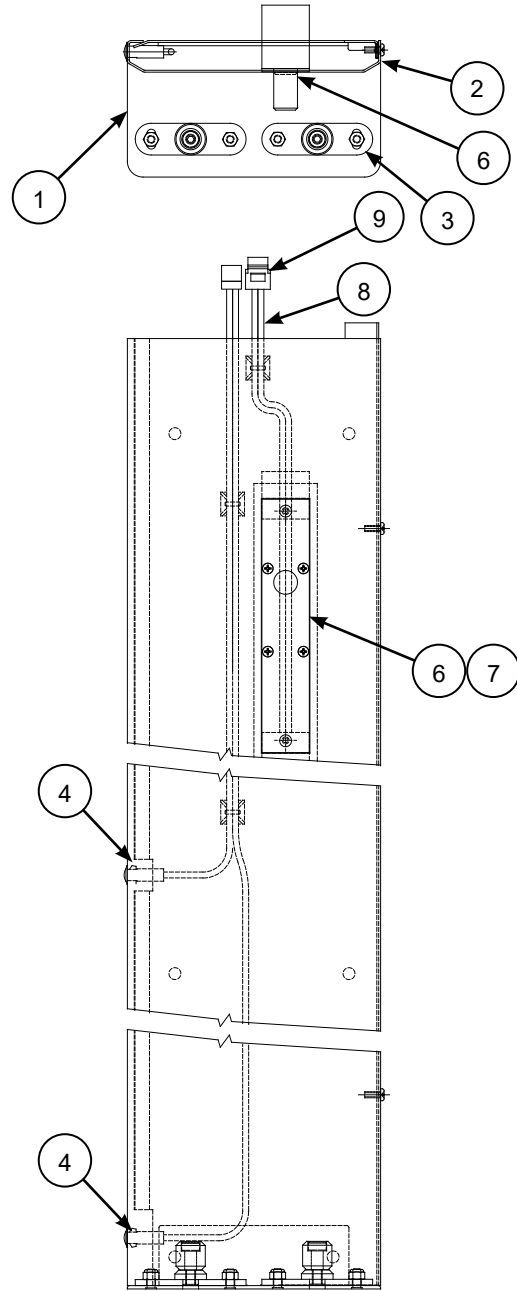

76D404 76D0406
BI-PART, RH BI-PART, RH
NO BOLT LOCK W/ BOLT LOCK

Face Frame Assemblies Continued

			DESCRIPTION	PART #	ITEM #
-	-	x	ASM, FACE FRAME, BI-PART, RH, NO BOLT LOCK	76D404	-
-	x	-	ASM, FACE FRAME, BI-PART, RH, W/ BOLT LOCK	76D0406	-
x	-	-	ASM, FACE FRAME, BI-PART, LH, NO BOLT LOCK	76D0408	-
1	-	1	WLDMNT, SIDE-FRAME, BI-PART	28C235	1
-	1	-	WLDMNT, SIDE-FRAME, BOLT LOCK, BI-PART	28B0285	1
1	-	1	COVER, SIDE FRAME, BI-PART, FIRE DOOR	13D326	1
-	1	-	WLDMNT, FACE FRAME COVER, BOLT LOCK	28B0299	2
2	2	2	ASM, GUIDE ROLLER	24A023	3
A/R	A/R	A/R	HARNESS, SINGLE PHOTO EYE, RECEIVER	23C023	4
A/R	A/R	A/R	HARNESS, SINGLE PHOTO EYE, TRANSMITTER	23C024	5
A/R	A/R	A/R	ASM, BOLT LOCK, 3/4" DIA	23A0376NN	6
A/R	A/R	A/R	COVER, BOLT LOCK	13B2191NN20	7
A/R	A/R	A/R	CABLE 18/3 SVT, 36"	22A208	8
A/R	A/R	A/R	CONNECTOR, ELEC, 4-POS, .156 MTA, FEMALE	22A203	9

**When ordering parts, specify
Job Number, Door Number
and Manufacture Date**

Header Assembly & Shroud

- 81D497F1, 0°, RH
- 81D497F2, 0°, RH
- 81D497F3, 30°, RH
- 81D497F4, 30°, RH
- 81D497F5, 45°, RH
- 81D497F6, 45°, RH

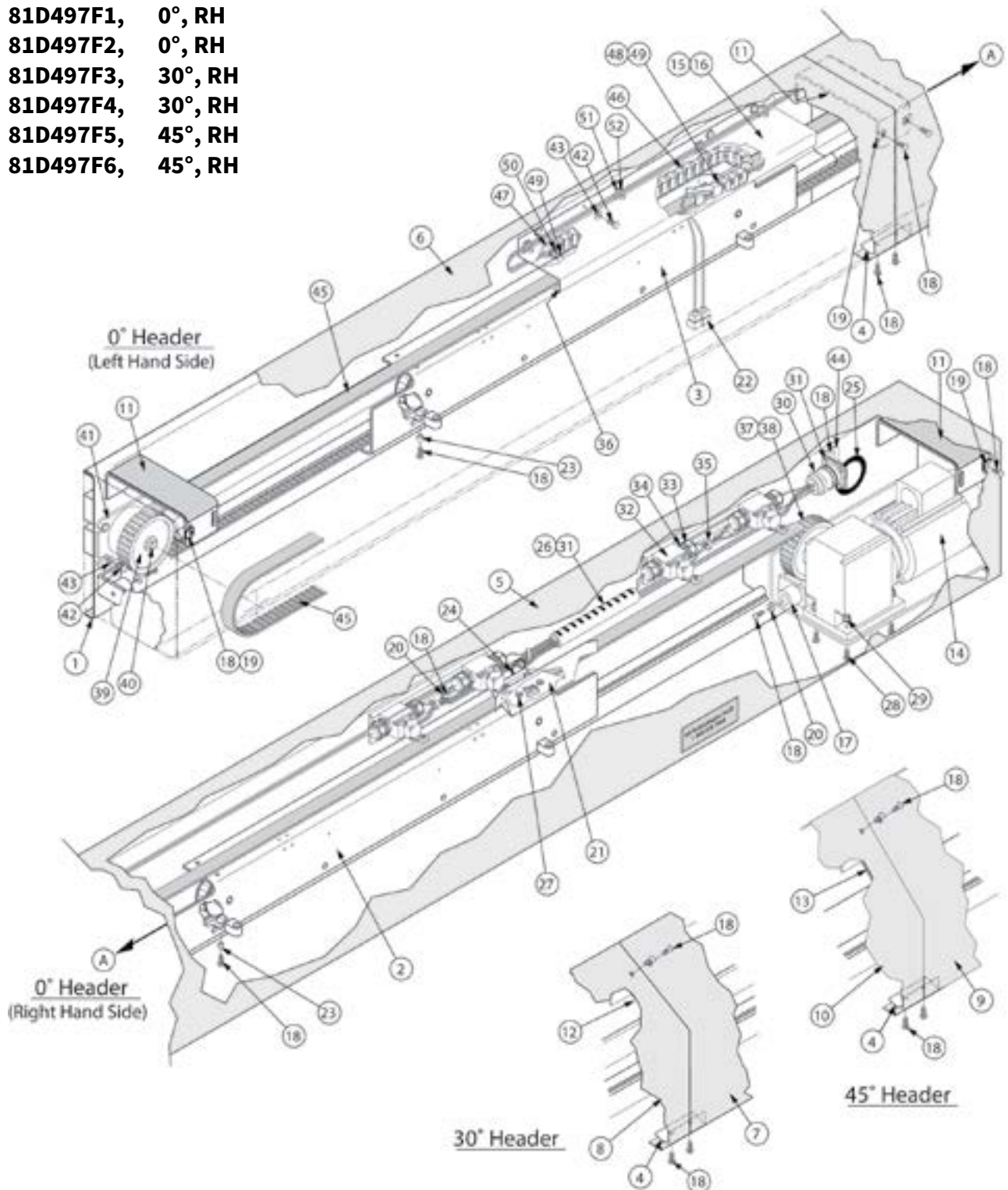

**When ordering parts, specify
Job Number, Door Number and
Manufacture Date**

Header Assembly & Shroud continued

81D497F1, 0°, RH
81D497F2, 0°, RH
81D497F3, 30°, RH
81D497F4, 30°, RH
81D497F5, 45°, RH
81D497F6, 45°, RH

Item	Part #	Description
1	28D211F1	Weldment, header, bi-parting, 0°, RH
-	28D211F2	Weldment, header, bi-parting, 0°, LH
-	28D211F3	Weldment, header, bi-parting, 30, RH
-	28D211F4	Weldment, header, bi-parting, 30°, LH
-	28D211F5	Weldment, header, bi-parting, 45°, RH
-	28D211F6	Weldment, header, bi-parting, 45°, LH
2	31D111F1	Assembly, upper truck, power, SS, RH drive
-	31D111F3	Assembly, upper truck, power, SS, LH drive
3	31D111F2	Assembly, upper truck, power, SS, RH idler
-	31D111F4	Assembly, upper truck, power, SS, LH idler
4	13B033	Angle, Shroud Stiffener
5	28D208F1	Weldment, shroud, 0°, power, RH operator end
-	28D208F3	Weldment, shroud, 0°, power, LH operator end
6	28D208F2	Weldment, shroud, 0°, power, RH idler end
-	28D208F4	Weldment, shroud, 0°, power, LH idler end
7	28D209F1	Weldment, shroud, 30°, power, RH operator end
-	28D209F3	Weldment, shroud, 30°, power, LH operator end
8	28D209F2	Weldment, shroud, 30°, power, RH idler end
-	28D209F4	Weldment, shroud, 30°, power, LH idler end
9	28D210F1	Weldment, shroud, 45°, power, RH operator end
-	28D210F3	Weldment, shroud, 45°, power, LH operator end
10	28D210F2	Weldment, shroud, 45°, power, RH idler end
-	28D210F4	Weldment, shroud, 45°, power, LH idler end
11	10A024	Tape, sponge rubber, 8.5" long
12	10A024	Tape, sponge rubber, 8" long
13	10A024	Tape, sponge rubber, 9" long
14	50B043F1	Assembly, gear motor, RH
-	50B043F2	Assembly, gear motor, LH
15	13D356F1	Guide, E-chain, RH
16	13D356F2	Guide, E-chain, LH
17	11A054	Pad, stop
18	41A535	Screw, 1/4"-20 x .625", BU/HD, SS
19	41A708	Nut, clip, 1/4"-20
20	41A195	Washer, flat, 1/4" standard, SS
21	13D336	Bracket, cam
22	22A203	Connector, electrical
23	13A395	Spacer, nylon guide
24	11A086	Grommet, rubber, .875" ID x 1.62" OD
25	11A087	Grommet, rubber, 2.12" ID x 2.87" OD
26	22A098	Duct, wire, (WIC - 51.0") long
27	41A715	Screw, #10-24 x .625", BU/HD, SS
28	41A616	Bolt, 3/8" x 1.25", carriage, SS
29	41A710	Nut, 3/8"-16, large flange, whizlock, SS
30	23D037	Harness, header, bi-parting
31	23A240	Switch, limit
32	41A717	Screw, #8-32 x .38", PHL PHSTS, SS
33	22A087	Strain relief, nylon
34	41A520	Screw, #8-32 x 1.25", PHL PHSTS, SS
35	22A107	Cable tie
36	10A023	Tape, UHMW, 2" wide x WIC - 8.5
37	50A101	Pulley, timing, 28T, .500" P
38	50A094	Bushing, taperlock, .875" bore
39	24B078	ASM, timing pulley, idle side
40	41A122	Bolt, 5/8" x 1.750" shoulder, ZN
41	28B133	Weldment, idler plate
42	41A611	Screw, 5/16"-18 x .625", HHCS, SS
43	41A608	Washer, flat, 5/16", standard, SS
44	13B644	Bracket, electrical connector
45	50A257	Belt timing, (4) WIC + 60"
46	22A212	Carrier, flexible cable
47	22A213	Bracket, mounting, flexible cable carrier
48	22A214	Bracket, mounting, flexible cable carrier
49	41A713	Screw, #4-40 x .38" long, PHL FHMS, SS
50	13A421	Washer, E-chain
51	22A218	Holder, cable tie
52	22A109-1	Cable tie, 3.5" long

When ordering parts, specify Job Number, Door Number and Manufacture Date

Upper Truck Assembly

- 31D111F1, RH, Drive
- 31D111F2, RH, Idler
- 31D111F3, LH, Drive
- 31D111F4, LH, Idler

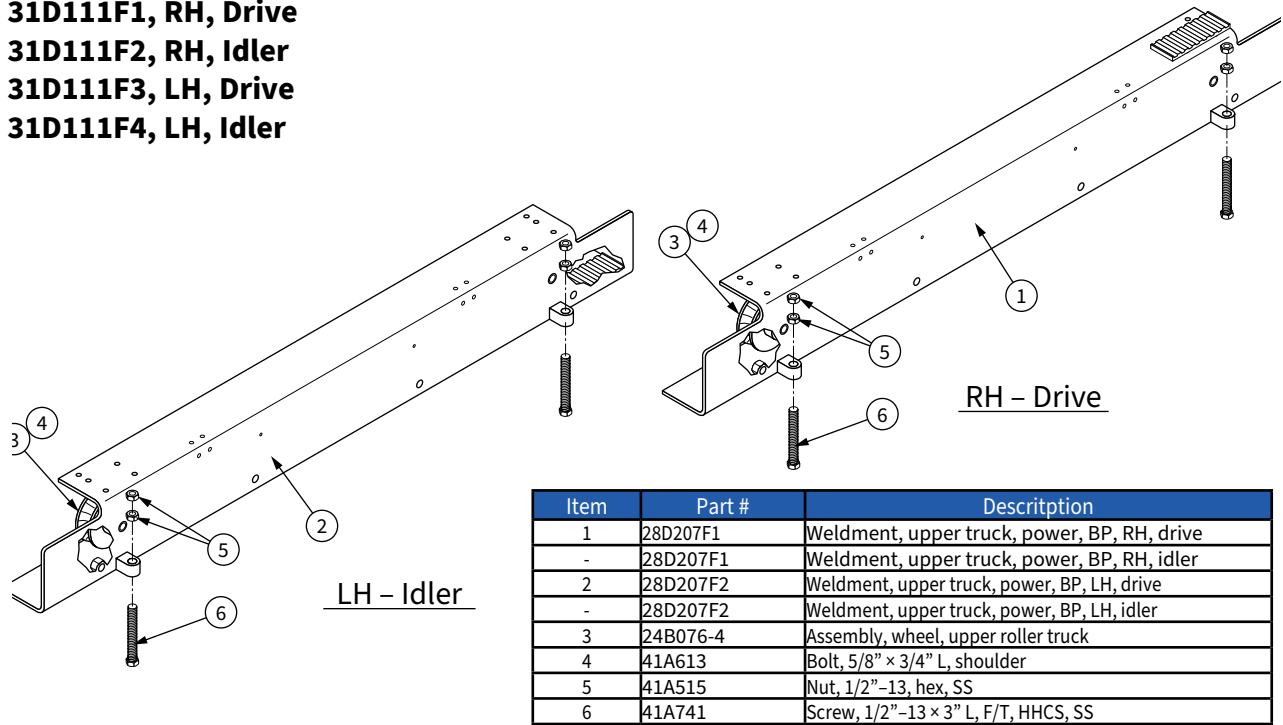

Item	Part #	Description
1	28D207F1	Weldment, upper truck, power, BP, RH, drive
-	28D207F1	Weldment, upper truck, power, BP, RH, idler
2	28D207F2	Weldment, upper truck, power, BP, LH, drive
-	28D207F2	Weldment, upper truck, power, BP, LH, idler
3	24B076-4	Assembly, wheel, upper roller truck
4	41A613	Bolt, 5/8" x 3/4" L, shoulder
5	41A515	Nut, 1/2"-13, hex, SS
6	41A741	Screw, 1/2"-13 x 3" L, F/T, HHCS, SS

Labels

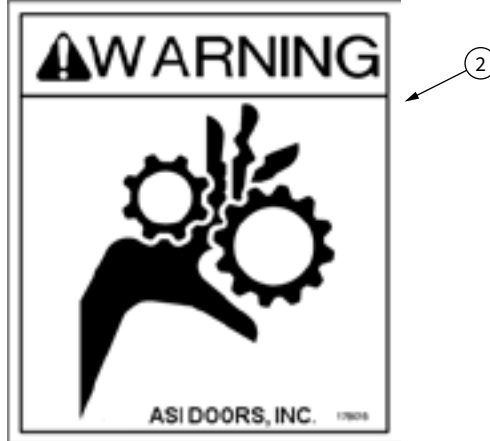
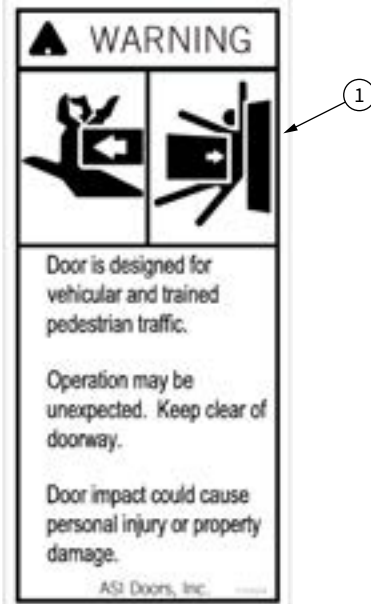

Item	Part #	Description
1	17A223	Nameplate, warning label
2	17B015	Label, warning, gears

**When ordering parts, specify
Job Number, Door Number and
Manufacture Date**

Gasket Retainer/Hold-In Brackets

- 24D127F1, No Photoeyes
- 24D127F2, Single Photoeyes
- 24D127F3, Dual Photoeye

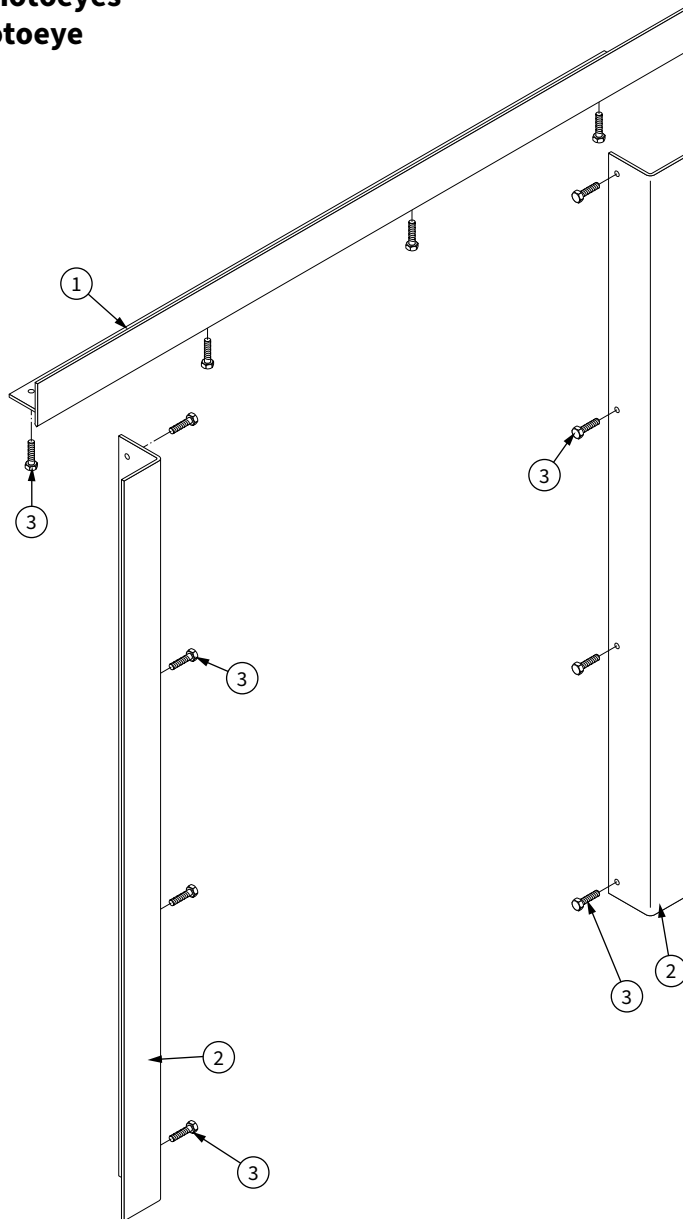

Item	Part #	Description
1	13C386F1	Hold-in bracket, top, S/S
2	13C387F1	Hold-in bracket, trailing edge, S/S
-	13C387F2	Hold-in bracket, trailing edge, photoeye, RH, S/S
-	13C387F3	Hold-in bracket, trailing edge, photoeye, LH, S/S
-	13C387F4	Hold-in bracket, trailing edge, dual photoeye, RH, S/S
-	13C387F5	Hold-in bracket, trailing edge, dual photoeye, LH, S/S
3	N/A	Screw, 3/8" (Supplied by Installer)

**When ordering parts, specify
Job Number, Door Number and
Manufacture Date**

Control Panel Assembly

18D350, 115V

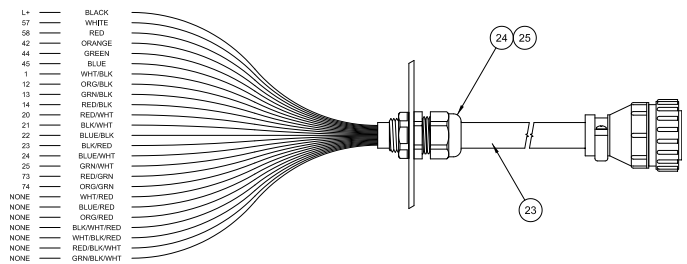
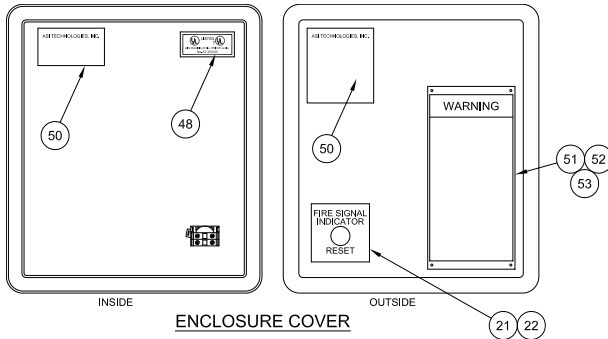
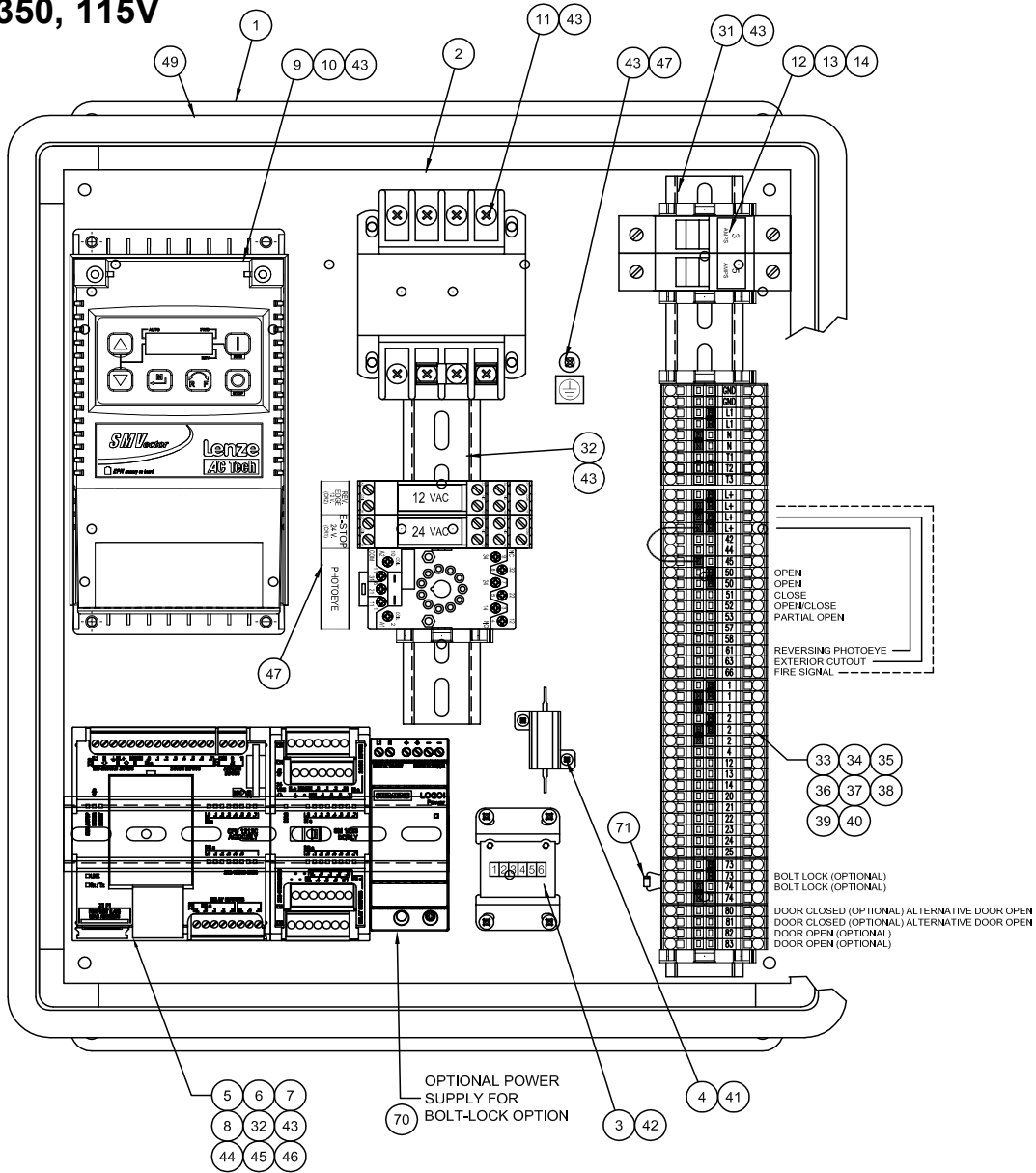

When ordering parts, specify Job Number, Door Number and Manufacture Date

REPLACEMENT PARTS

Control Panel Assembly continued

Item	Part #	Description
1	14D011	Enclosure, 16" x 14"
2	13C0455	Subpanel
3	23A003	Counter, 24 VAC
4	23A190-200	Resistor, 200 Ohms
5	23A0490	Programmable Logic Controller
6	18B022-2	Program, Seimens PLC
7	23A0491	PLC Auxiliary Module
8	23A0492	PLC, Timer Potentiometer
9	23B0175	VFD, 120 VAC
10	18B011-SMV	Parameter Settings, AC Tech VFD, SMV
11	23B040	Transformer, 120/240V to 24V
12	23A239	Block, Fuse, 2 Pole
13	22A210-2	Fuse, Midget, 3 Amp
14	22A210-3	Fuse, Midget, 5 Amp
15	22A233	Base, 11 Pin
16	23A226	Amplifier, Photoeye, Dual Channel
17	23A232	Base, Relay, Finder
18	23A234	Relay, 24 VAC, Finder
19	23A235	Relay, 12 VAC, Finder
20	23A241	Suppressor, RC, Finder
21	22A060	Pushbutton, Illuminated, Yellow
22	17B023	Label, Fire Signal/Reset
23	23C022F1	Harness, 19 Conductor, 16' Long
23	23C022F3	Harness, 19 Conductor, Specified Length
24	22A217	Strain Relief, Nylon
25	22A196	Locknut, Nylon

Item	Part #	Description
31	22A006	Rail, DIN, 375 mm (14.76")
32	22B026	Rail, DIN, 175 mm
33	22A0333	Block, Terminal, End Stop
34	22A0332	Block, Terminal, End Plate
35	22A0331	Block, Terminal, Ground
36	22A0330	Block, Terminal
37	22A0347	Block, Terminal, End Plate, Oversized
38	22A0339	Jumper, 2-Terminals
39	22A0340	Jumper, Push-In Wire, 60 mm
40	22A0348	Label, Terminal
41	41A052	Screw, #4-40 x .250", PAN, PHL
42	41A720	Screw, #6-32 x .375", PAN, PHL, Type "F"
43	41A721	Screw, #10-32 x .375", PAN, PHL, Type "F"
44	17A0345	Label, PLC, Input
45	17A0346	Label, PLC, Output
46	17A0347	Label, PLC, POT
47	17B020	Label, Subpanel
48	17A107	Label, UL 508
49	17A231	Label, Drilling Enclosure
50	17B007	Label, Door & Operator ID
51	17C012	Label, Warning
52	13B684	Plate, Mounting, Warning Label
53	41A008	Rivet, Pop, .125 Dia
70	23A267	Power Supply (Optional Bolt Lock)
71	23A249	Diode, IN4007 (Optional Bolt Lock)
23	23C022F2	Harness, 25 Conductor, 16' Long (Bolt Lock)
23	23C022F2	Harness, 25 Conductor, Spec'd Length (Bolt Lock)

Fire/Heat Sensor Options

Item	Part #	Description
1	23A0452	SMOKE DETECTOR, PHOTOELECTRIC, W/ ALARM & STROBE, 517TCSB-W
2	23A0466	HEAT DETECTOR, SURFACE MOUNT, 12-A27020-001-140

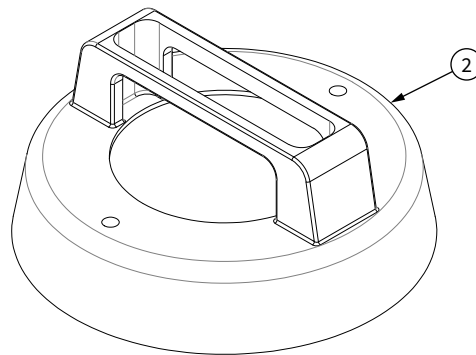
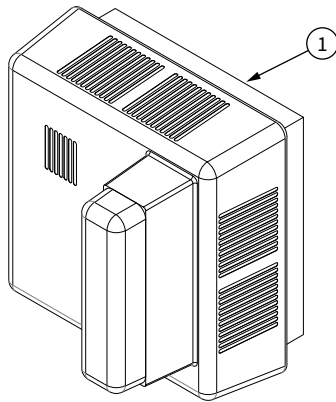

**When ordering parts, specify
Job Number, Door Number and
Manufacture Date**



OPEN UP TO WHAT'S POSSIBLE



asidoors.com