

INSTRUCTION BOOK

OIL-FREE SCROLL COMPRESSORS

SF 1, SF 2, SF 4, SF 6



Atlas Copco

Oil-free scroll compressors

SF 1, SF 2, SF 4, SF 6

Instruction book

Original instructions

COPYRIGHT NOTICE

Any unauthorized use or copying of the contents or any part thereof is prohibited.

This applies in particular to trademarks, model denominations, part numbers and drawings.

This instruction book is valid for CE as well as non-CE labelled machines. It meets the requirements for instructions specified by the applicable European directives as identified in the Declaration of Conformity.

2021 - 02

No. 2920 7110 13

www.atlascopco.com



Table of contents



| | | |
|----------|--|-----------|
| 1 | Safety precautions..... | 4 |
| 1.1 | SAFETY ICONS..... | 4 |
| 1.2 | SAFETY PRECAUTIONS, GENERAL..... | 4 |
| 1.3 | SAFETY PRECAUTIONS DURING INSTALLATION..... | 5 |
| 1.4 | SAFETY PRECAUTIONS DURING OPERATION..... | 6 |
| 1.5 | SAFETY PRECAUTIONS DURING MAINTENANCE OR REPAIR..... | 7 |
| 1.6 | DISMANTLING AND DISPOSAL..... | 9 |
| 2 | General description..... | 10 |
| 2.1 | INTRODUCTION..... | 10 |
| 2.2 | FLOW DIAGRAM..... | 15 |
| 2.3 | REFRIGERANT DRYER..... | 17 |
| 3 | Installation..... | 20 |
| 3.1 | DIMENSION DRAWINGS..... | 20 |
| 3.2 | INSTALLATION PROPOSAL..... | 21 |
| 3.3 | ELECTRICAL CONNECTIONS..... | 23 |
| 3.4 | PICTOGRAPHS..... | 24 |
| 4 | Operation..... | 26 |
| 4.1 | INITIAL START-UP..... | 26 |
| 4.2 | STARTING..... | 27 |
| 4.3 | DURING OPERATION..... | 28 |
| 4.4 | STOPPING..... | 28 |
| 4.5 | TAKING OUT OF OPERATION..... | 29 |
| 5 | Preventive maintenance..... | 30 |
| 5.1 | PREVENTIVE MAINTENANCE SCHEDULE..... | 30 |

| | | |
|-----------|---|-----------|
| 5.2 | SERVICE KITS..... | 32 |
| 6 | Adjustments and servicing procedures..... | 33 |
| 6.1 | PRESSURE SWITCH..... | 33 |
| 6.2 | AIR FILTER..... | 34 |
| 6.3 | AIR COOLER..... | 35 |
| 6.4 | DRIVE MOTOR..... | 35 |
| 6.5 | SAFETY VALVE | 35 |
| 6.6 | BELT REPLACEMENT..... | 36 |
| 6.7 | TEMPERATURE PROTECTION..... | 38 |
| 6.8 | CLEANING THE COMPRESSOR ELEMENT..... | 38 |
| 6.9 | REPLACEMENT OF THE OUTLET PIPE..... | 39 |
| 6.10 | REFRIGERANT DRYER MAINTENANCE..... | 40 |
| 7 | Problem solving..... | 42 |
| 8 | Technical data..... | 44 |
| 8.1 | READINGS ON CONTROL PANEL..... | 44 |
| 8.2 | ELECTRIC CABLE SIZE..... | 44 |
| 8.3 | SETTINGS FOR OVERLOAD RELAY AND FUSES..... | 45 |
| 8.4 | TEMPERATURE PROTECTION AND SAFETY VALVE SETTINGS..... | 46 |
| 8.5 | REFERENCE CONDITIONS AND LIMITATIONS..... | 47 |
| 8.6 | COMPRESSOR DATA..... | 47 |
| 9 | Instructions for use..... | 49 |
| 10 | Guidelines for inspection..... | 50 |
| 11 | Pressure equipment directives..... | 51 |
| 12 | Declaration of conformity..... | 52 |

1 Safety precautions

1.1 Safety icons

Explanation

| | |
|---|----------------|
|  | Danger to life |
|  | Warning |
|  | Important note |

1.2 Safety precautions, general

General precautions

1. The operator must employ safe working practices and observe all related work safety requirements and regulations.
2. If any of the following statements does not comply with the applicable legislation, the stricter of the two shall apply.
3. Installation, operation, maintenance and repair work must only be performed by authorized, trained, specialized personnel.
4. Never use compressed air as breathing air without prior purification in accordance with local legislation and standards.
5. Before any maintenance, repair work, adjustment or any other non-routine checks, stop the compressor, press the emergency stop button, switch off the voltage and depressurize the compressor. In addition, the power isolating switch must be opened and locked.
6. Never play with compressed air. Do not apply the air to your skin or direct an air stream at people. Never use the air to clean dirt from your clothes. When using the air to clean equipment, do so with extreme caution and wear eye protection.
7. The owner is responsible for maintaining the unit in safe operating condition. Parts and accessories shall be replaced if unsuitable for safe operation.
8. It is not allowed to walk or stand on the compressor or its components.

1.3 Safety precautions during installation



All responsibility for any damage or injury resulting from neglecting these precautions, or non observance of the normal caution and care required for installation, operation, maintenance and repair, even if not expressly stated, will be disclaimed by the manufacturer.

These precautions apply to machinery processing or consuming air or inert gas. Processing of any other gas requires additional safety precautions typical to the application which are not included herein.

Some precautions are general and cover several machine types and equipment; hence some statements may not apply to your machine.

Precautions during installation

1. The machine must only be lifted using suitable equipment in accordance with local safety regulations. Loose or pivoting parts must be securely fastened before lifting. It is strictly forbidden to dwell or stay in the risk zone under a lifted load. Lifting acceleration and deceleration must be kept within safe limits. Wear a safety helmet when working in the area of overhead or lifting equipment.
2. Place the machine where the ambient air is as cool and clean as possible. If necessary, install a suction duct. Never obstruct the air inlet. Care must be taken to minimise the entry of moisture at the inlet air. Consult section Reference conditions and limitations.
3. Any blanking flanges, plugs, caps, desiccant bags, packaging films, and transport brackets must be removed before connecting the pipes.
4. Air hoses must be of correct size and suitable for the working pressure. Never use frayed, damaged or worn hoses. Distribution pipes and connections must be of the correct size and suitable for the working pressure.
5. The aspirated air must be free of flammable fumes, vapours, and particles, e.g. paint solvents, which can lead to internal fire or explosion.
6. Arrange the air intake so that loose clothing worn by people cannot be sucked in.
7. Ensure that the discharge pipe from the compressor to the aftercooler or air net is free to expand under heat and that it is not in contact with or close to flammable materials.
8. No external force may be exerted on the air outlet valve. The connected pipe must be free of strain.
9. If remote control is installed, the machine must bear a clear sign stating "DANGER: This machine is remotely controlled and may start without warning".
The operator has to make sure that the machine is stopped and that the isolating switch is open and locked before any maintenance or repair. As a further safeguard, persons switching on remotely controlled machines shall take adequate precautions to ensure that there is no one checking or working on the machine. To this end, a suitable notice shall be affixed to the start equipment.
10. Air-cooled machines must be installed in such a way that an adequate flow of cooling air is available and that the exhausted air does not recirculate to the compressor air inlet or cooling air inlet.
11. The electrical connections must correspond to the applicable codes. The machines must be earthed and protected against short circuits by fuses in all phases. A lockable power isolating switch must be installed near the compressor.
12. On machines with automatic start-stop system or if the automatic restart function after voltage failure is activated, a sign stating "This machine may start without warning" must be affixed near the instrument panel.

13. In multiple compressor systems, manual valves must be installed to isolate each compressor. Non-return valves (check valves) must not be relied upon for isolating pressure systems.
14. Never remove or tamper with the safety devices, guards or insulation fitted on the machine. Every pressure vessel or auxiliary installed outside the machine to contain air above atmospheric pressure must be protected by a pressure relieving device or devices as required.
15. Piping or other parts with a temperature in excess of 80°C (176°F) and which may be accidentally touched by personnel in normal operation must be guarded or insulated. Other high temperature piping must be clearly marked.
16. For water-cooled machines, the cooling water system installed outside the machine has to be protected by a safety device with set pressure according to the maximum cooling water inlet pressure.
17. If the ground is not level or can be subject to variable inclination, consult the manufacturer.



Also consult following safety precautions: [Safety precautions during operation](#) and [Safety precautions during maintenance](#).

1.4 Safety precautions during operation



All responsibility for any damage or injury resulting from neglecting these precautions, or non observance of the normal caution and care required for installation, operation, maintenance and repair, even if not expressly stated, will be disclaimed by the manufacturer.

These precautions apply to machinery processing or consuming air or inert gas. Processing of any other gas requires additional safety precautions typical to the application which are not included herein.

Some precautions are general and cover several machine types and equipment; hence some statements may not apply to your machine.

Precautions during operation

1. Never touch any piping or components of the compressor during operation.
2. Use only the correct type and size of hose end fittings and connections. When blowing through a hose or air line, ensure that the open end is held securely. A free end will whip and may cause injury. Make sure that a hose is fully depressurized before disconnecting it.
3. Persons switching on remotely controlled machines shall take adequate precautions to ensure that there is no one checking or working on the machine. To this end, a suitable notice shall be affixed to the remote start equipment.
4. Never operate the machine when there is a possibility of taking in flammable or toxic fumes, vapors or particles.
5. Never operate the machine below or in excess of its limit ratings.
6. Keep all bodywork doors shut during operation. The doors may be opened for short periods only, e.g. to carry out routine checks. Wear ear protectors and safety glasses when opening a door.
7. People staying in environments or rooms where the sound pressure level reaches or exceeds 90 dB(A) shall wear ear protectors.
8. Periodically check, when the unit is off, that:
 - All guards are in place and securely fastened

- All hoses and/or pipes inside the machine are in good condition, secure and not rubbing
 - There are no leaks
 - All fasteners are tight
 - All electrical leads are secure and in good order
 - Safety valves and other pressure relief devices are not obstructed by dirt or paint
 - Air outlet valve and air net, i.e. pipes, couplings, manifolds, valves, hoses, etc. are in good condition, free of wear or abuse
9. If warm cooling air from compressors is used in air heating systems, e.g. to warm up a working area, take precautions against air pollution and possible contamination of the breathing air.
 10. Do not remove any of, or tamper with, the sound dampening material.
 11. Never remove or tamper with the safety devices, guards or insulation fitted to the machine. Every pressure vessel or auxiliary installed outside the machine to contain air above atmospheric pressure shall be protected by a pressure relieving device or devices as required.
 12. Be aware of possible blow off of safety valves during operation. For the location of the safety valves, consult the description in this instruction book.
 13. Yearly inspect the air receiver. Minimum wall thickness as specified in the instruction book must be respected. Local regulations remain applicable if they are more strict.
 14. If automatic restart after voltage failure (ARAVF) is activated and provided the controller was in the automatic operation mode, the compressor will automatically restart if the supply voltage to the module is restored.



Also consult the following safety precautions: [Safety precautions during installation](#) and [Safety precautions during maintenance](#).

1.5 Safety precautions during maintenance or repair



All responsibility for any damage or injury resulting from neglecting these precautions, or non observance of the normal caution and care required for installation, operation, maintenance and repair, even if not expressly stated, will be disclaimed by the manufacturer.

These precautions apply to machinery processing or consuming air or inert gas. Processing of any other gas requires additional safety precautions typical to the application which are not included herein.

Some precautions are general and cover several machine types and equipment; hence some statements may not apply to your machine.

Precautions during maintenance or repair

1. Always use the correct safety equipment such as safety glasses, gloves, safety shoes, etc.
2. Use only the correct tools for maintenance and repair work.
3. Use only genuine spare parts.
4. All maintenance work shall only be undertaken when the machine has cooled down.
5. A warning sign bearing a legend such as "Work in progress; do not start" shall be attached to the starting equipment.
6. Persons switching on remotely controlled machines shall take adequate precautions to ensure that there is no one checking or working on the machine. To this end, a suitable notice shall be affixed to the remote start equipment.

7. Close the compressor air outlet valve before connecting or disconnecting a pipe.
8. Before removing any pressurized component, effectively isolate the machine from all sources of pressure and relieve the entire system of pressure.
9. Never use flammable solvents or carbon tetrachloride for cleaning parts. Take safety precautions against toxic vapours of cleaning liquids.
10. Scrupulously observe cleanliness during maintenance and repair. Keep dirt away by covering the parts and exposed openings with a clean cloth, paper or tape.
11. Never weld or perform any operation involving heat near any oil system. Oil tanks must be completely purged, e.g. by steam-cleaning, before carrying out such operations. Never weld on, or in any way modify, pressure vessels.
12. Whenever there is an indication or any suspicion that an internal part of a machine is overheated, the machine shall be stopped but no inspection covers shall be opened before sufficient cooling time has elapsed to avoid spontaneous ignition of the oil vapour (if applicable) when air is admitted.
13. Never use a light source with open flame for inspecting the interior of a machine, pressure vessel, etc.
14. Make sure that no tools, loose parts or rags are left in or on the machine.
15. All regulating and safety devices shall be maintained with due care to ensure that they function properly. They may not be put out of action.
16. Before clearing the machine for use after maintenance or overhaul, check that operating pressures, temperatures and time settings are correct. Check that all control and shut-down devices are fitted and that they function correctly. If removed, check that the coupling guard of the compressor drive shaft has been reinstalled.
17. Protect the motor, air filter, electrical and regulating components, etc. to prevent moisture from entering them, e.g. when steam-cleaning.
18. Make sure that all sound-damping material, e.g. on the bodywork and in the air inlet and outlet systems of the compressor, is in good condition. If damaged, replace it by genuine material from the manufacturer to prevent the sound pressure level from increasing.
19. Never use caustic solvents which can damage materials of the air net, e.g. polycarbonate bowls.
20. **The following safety precautions are stressed when handling refrigerant:**
 - Never inhale refrigerant vapours. Check that the working area is adequately ventilated; if required, use breathing protection.
 - Always wear special gloves. In case of refrigerant contact with the skin, rinse the skin with water. If liquid refrigerant contacts the skin through clothing, never tear off or remove the latter; flush abundantly with fresh water over the clothing until all refrigerant is flushed away; then seek medical first aid.
21. Protect hands to avoid injury from hot machine parts, e.g. during draining of oil.
22. Be aware of eventual sharp edges on certain parts of the machine.
23. If automatic restart after voltage failure (ARAVF) is activated and provided the controller was in the automatic operation mode, the compressor will automatically restart if the supply voltage to the module is restored.



Also consult the following safety precautions: [Safety precautions during installation](#) and [Safety precautions during operation](#).

1.6 Dismantling and disposal

Dismantling

Once the end of life of the machine is reached, please follow next steps:

1. Stop the machine.
2. Check all safety precautions mentioned in the previous chapters to secure safe handling (e.g. LOTO, cool-down, depressurize, discharge, ...).
3. Separate the harmful from the safe components (e.g. drain oil from oil containing parts).
4. Refer to the disposal topic mentioned below.

Disposal of electrical and electronic appliances (WEEE)

This equipment falls under the provisions of the European Directive 2012/19/EU on waste electrical and electronic appliances (WEEE) and may not be disposed as unsorted waste.



The equipment is labelled in accordance with the European Directive 2012/19/EU with the crossed-out wheeled bin symbol.

At the end of life-time of the electric and electronic equipment (EEE) it must be taken to separate collection.

For more information check with your local waste authority, customer center or distributor.

Disposal of other used material

Used filters or any other used material (e.g. filter bags, filter media, desiccant, lubricants, cleaning rags, machine parts, etc.) must be disposed of in an environmentally friendly and safe manner, and in line with the local recommendations and environmental legislation.

2 General description

2.1 Introduction

General

SF 1, SF 2, SF 4 and SF 6 are stationary, single stage, oil-free compressors, driven by an electric motor.

The compressors are controlled by a pressure switch.

The compressors are enclosed in a sound dampening enclosure and are air-cooled.

Available versions:

- The Pack version (P) comprises the motor, the compressor element, the air-cooled aftercooler, and the regulation and protection components.
- The Full-Feature (FF) version is a Pack version, completed with an integrated refrigerant dryer.

The basic version (referred to as the floor-mounted version (FM)) does not include an air receiver.

Available options:

- Air receiver of 30 l (7.93 US gal), 270 l (71.3 US gal) or 500 l (132 US gal). The 30 l receiver consists of a module with three 10 l (2.64 US gal) receivers. The 30 l receiver option includes an electronic drain.
- Electronic drain on the air receiver in the tank-mounted version (270 l and 500 l).
- Water separator on the outlet in floor-mounted compressors without refrigerant dryer.
- Prefilter mats on the air inlet
- Phase sequence relay on 3-phase units.
- Remote air intake

SF Pack

The control panel comprises a pressure gauge, an hour meter and a start button. The compressor is controlled by a pressure switch (PS).

The electric components are located in the cubicle behind the front panel door.

A check valve (CV) prevents loss of compressed air when the compressor is stopped.

A temperature switch and a safety valve (SV) protect the compressor element against overheating and too high pressure respectively.

The compressed air is cooled by an air cooler (Ca).

Single phase units are equipped with a vent valve for easy starting.

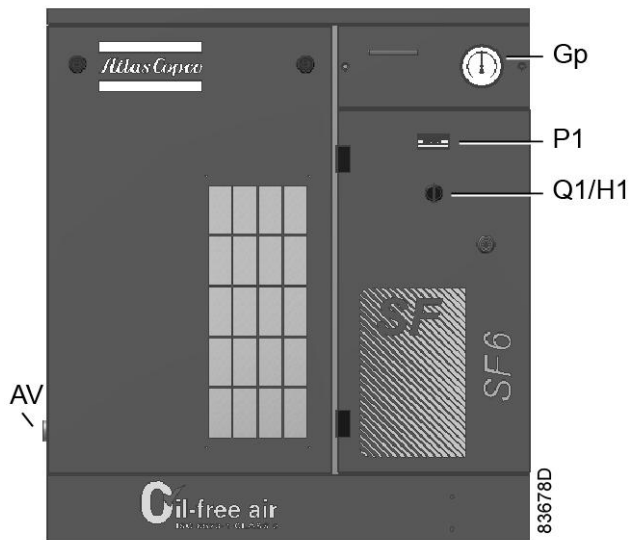

SF 6 P - floor-mounted - general view

| | | | |
|----|----------------|-------|-------------------------|
| Gp | Pressure gauge | Q1/H1 | On/off switch with lamp |
| P1 | Hour meter | AV | Outlet valve |

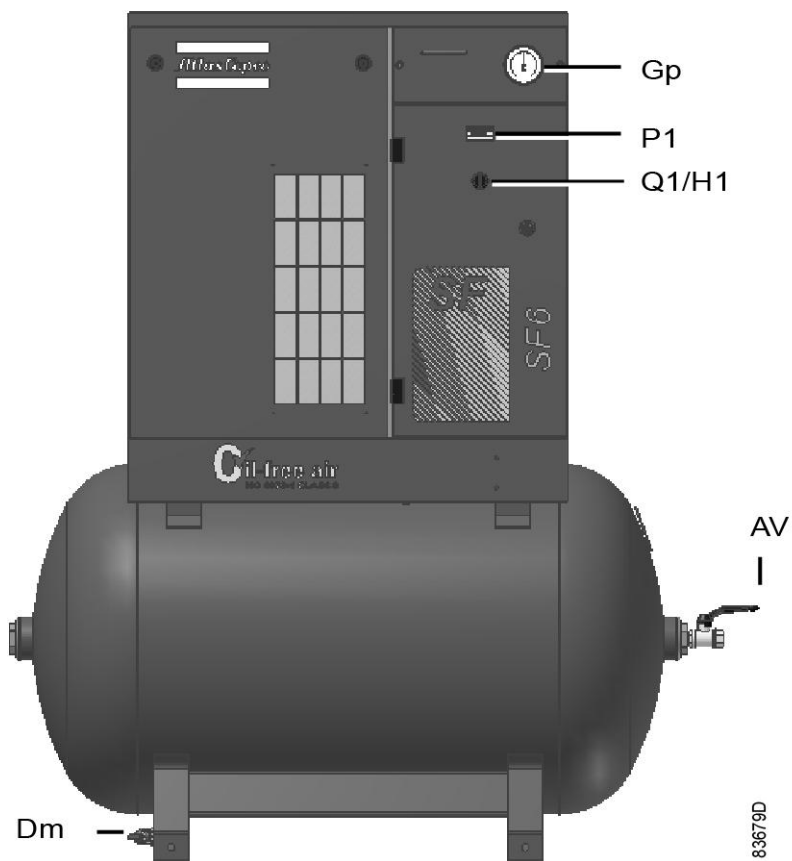

SF 6 P on a 270 l receiver - general view

| | | | |
|----|--------------------|-------|-------------------------|
| Gp | Pressure gauge | Q1/H1 | On/off switch with lamp |
| P1 | Hour meter | AV | Air outlet valve |
| Dm | Manual drain valve | | |

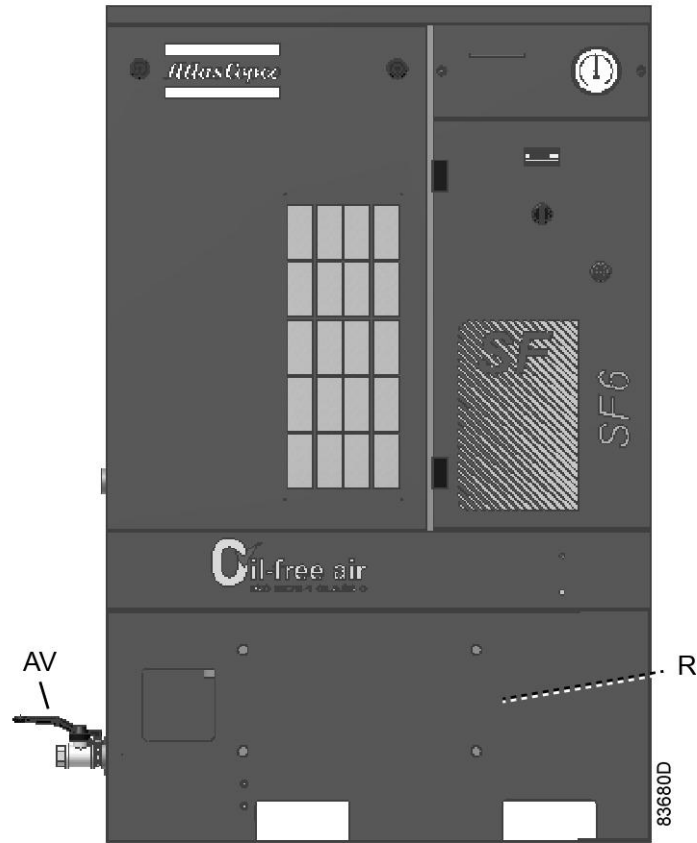

SF 6 P with integrated air receivers (3 x 10 l) - general view

| | | | |
|---|-------------------|----|------------------|
| R | 3 x 10 l receiver | AV | Air outlet valve |
|---|-------------------|----|------------------|

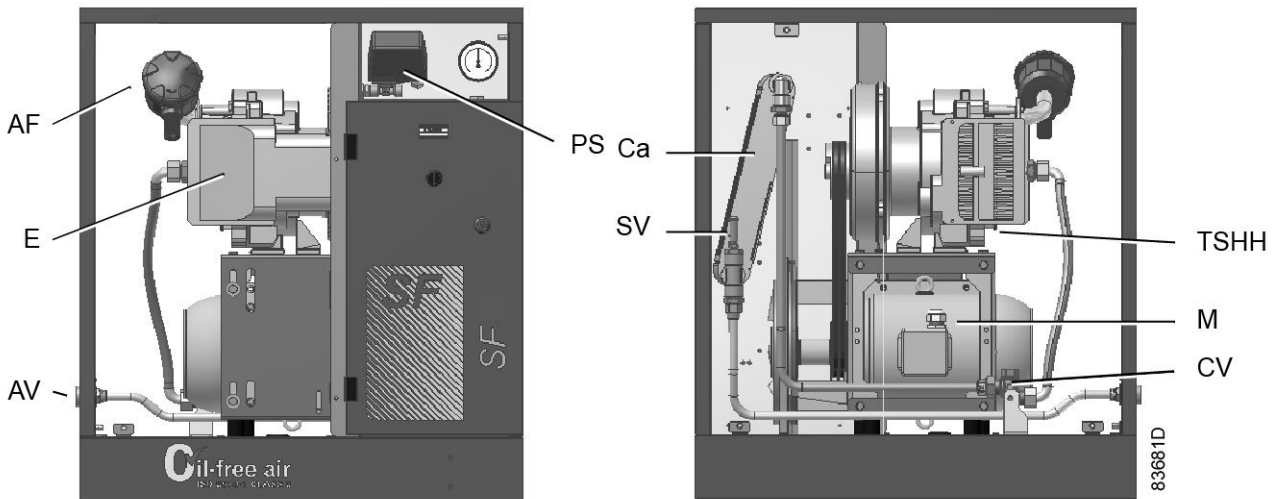

SF 4 P - details

| | | | |
|----|------------------|------|--------------------|
| AF | Inlet air filter | AV | Air outlet valve |
| Ca | Air cooler | E | Compressor element |
| M | Motor | PS | Pressure switch |
| SV | Safety valve | TSHH | Temperature switch |
| CV | Check valve | | |

SF Full-Feature

The control panel comprises a pressure gauge, an hour meter, a start button and a temperature gauge indicating the dew point (Gd). The compressor is controlled by a pressure switch.

The electric components are located in the cubicle behind the front panel door.

A check valve (CV) prevents loss of compressed air when the compressor is stopped.

A temperature switch and a safety valve (SV) protect the compressor element against overheating and too high pressure respectively.

The compressed air is cooled by an air cooler (Ca) before it enters the dryer.

Single phase units are equipped with a vent valve for easy starting.

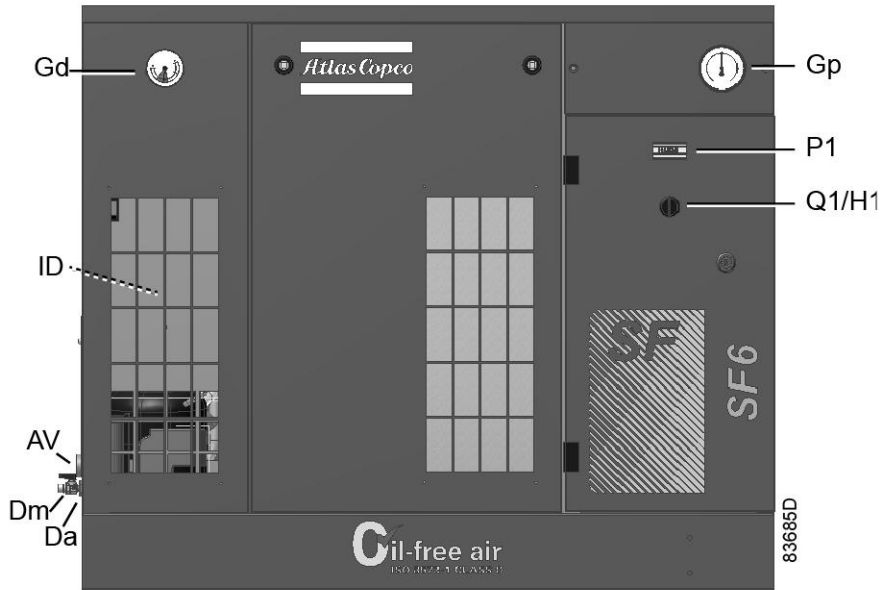

SF 6 FF floor-mounted - general view

| | | | |
|----|--------------------|-------|-------------------------|
| Gp | Pressure gauge | Q1/H1 | On/off switch with lamp |
| P1 | Hour meter | AV | Air outlet valve |
| Dm | Manual drain valve | Da | Automatic drain outlet |
| Gd | Dew point gauge | ID | Refrigerant dryer |

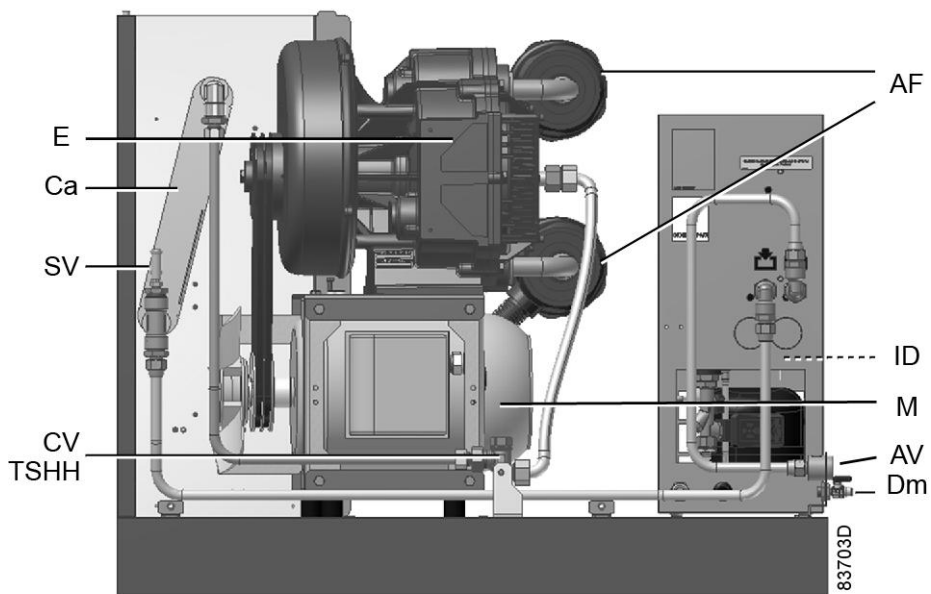

SF 6 FF - details

| | | | |
|----|-------------------|------|--------------------|
| AF | Inlet air filter | AV | Air outlet valve |
| Ca | Air cooler | E | Compressor element |
| M | Motor | CV | Check valve |
| SV | Safety valve | Dm | Manual drain valve |
| ID | Refrigerant dryer | TSHH | Temperature switch |

2.2 Flow diagram

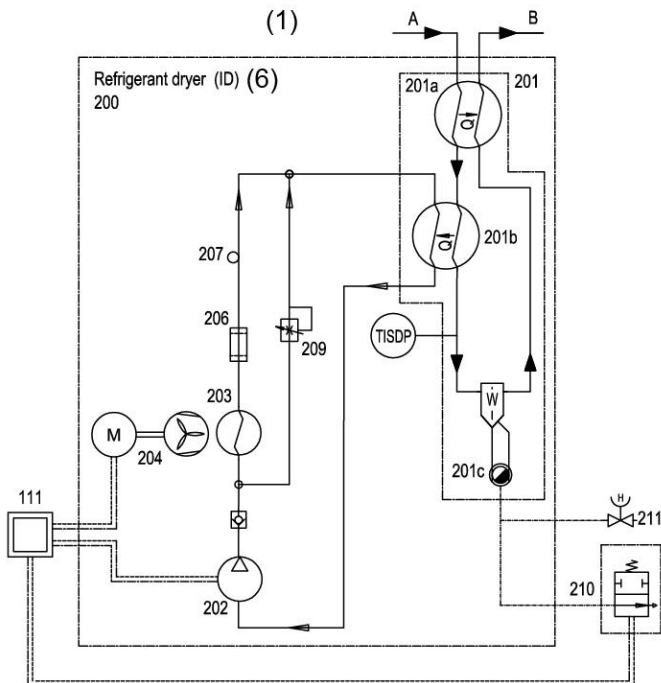
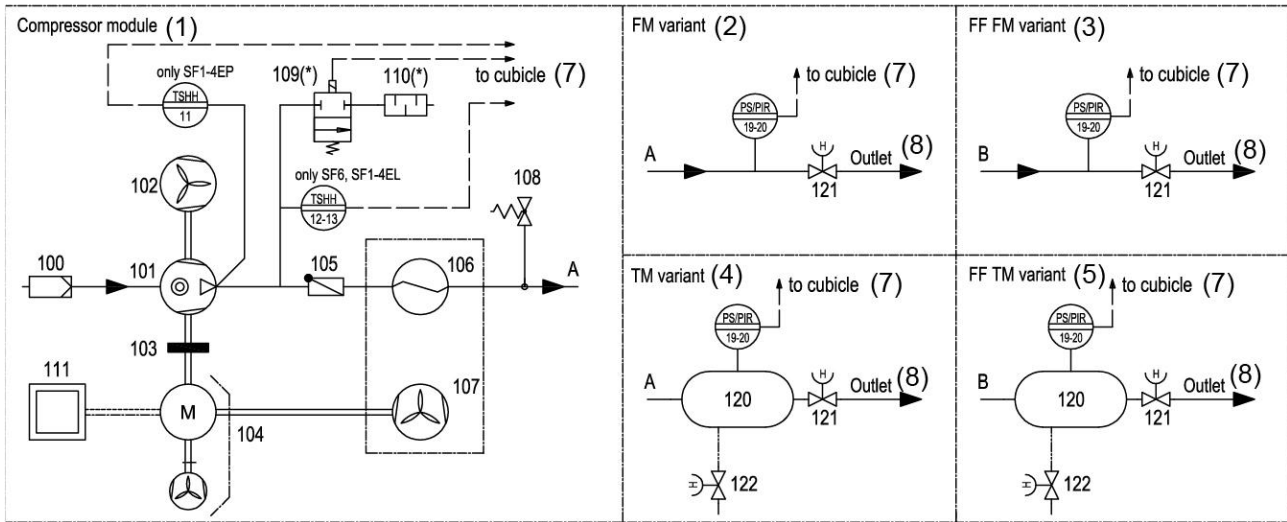

9820 6376 15 ed. 00

83688D

Flow diagram

| | | | |
|-----|--------------------------------------|-----|----------------------------------|
| (1) | Compressor module | (5) | Units with dryer on air receiver |
| (2) | Units without dryer and air receiver | (6) | Refrigerant dryer |
| (3) | Units with dryer, without receiver | (7) | To cubicle |
| (4) | Units without dryer on air receiver | (8) | Compressed air outlet |

Air flow

Air is drawn through air filter (100) and is compressed by the compressor element (101). Next, the compressed air flows through the check valve (105) and the air cooler (106).

Single phase units are equipped with a solenoid valve (109) and a silencer (110) for easy starting at low voltage.

On floor mounted versions without refrigerant dryer, the air flows then directly to the outlet valve (121). On receiver mounted units, the compressed air flows into the air receiver (120), onto which the outlet valve AV (121) is fitted.

On compressors with refrigerant dryer, the compressed air flows to the refrigerant dryer (ID), where the water vapor condensates by cooling down. The water is removed via the integrated water separator (201c) and the electronic drain (210).

The compressed air flows to the refrigerant dryer (ID), where the water vapor condensates by cooling down. The water is removed via the integrated water separator (201c) and the electronic drain (210).

For details on the operation of the ID dryer, see section [Refrigerant dryer](#).

Cooling

The compressor element (101) is cooled by an integrated radial fan (102). An axial fan (107) fitted on the motor shaft provides cooling air for the air cooler (106).

On compressors with integrated refrigerant dryer, a separate fan (204) delivers cooling air for the dryer.

Condensate management

Floor-mounted compressors without refrigerant dryer have no drain. A water separator is available as option.

The dryer of compressors equipped with a refrigerant dryer has an integrated water separator (201c) and an electronic water drain (210). The water separator has a manual drain valve (211) and a connection for the automatic drain. For more details, consult section [Refrigerant dryer](#).

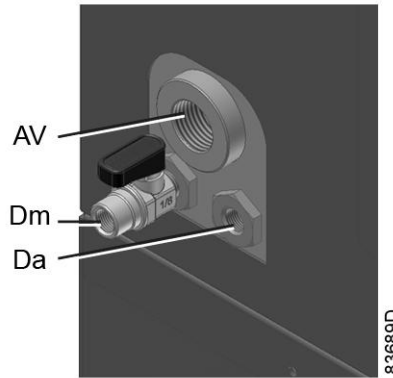

The receiver of tank-mounted compressors has a manual drain valve (122) at the bottom. An electronic condensate drain is available as option.

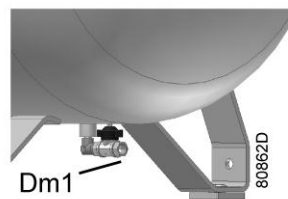

Regulating system and protection

The compressor is started and stopped automatically by a pressure switch (PS). A pressure gauge (PI) indicates the pressure. A temperature switch (TSHH) protects the compressor element from too high temperatures.

A safety valve (108) protects the compressor element against too high pressure.

2.3 Refrigerant dryer

Operation

The refrigerant dryer removes moisture from the compressed air by cooling it down to near freezing temperature. The water is removed via an automatic drain.

Compressed air circuit

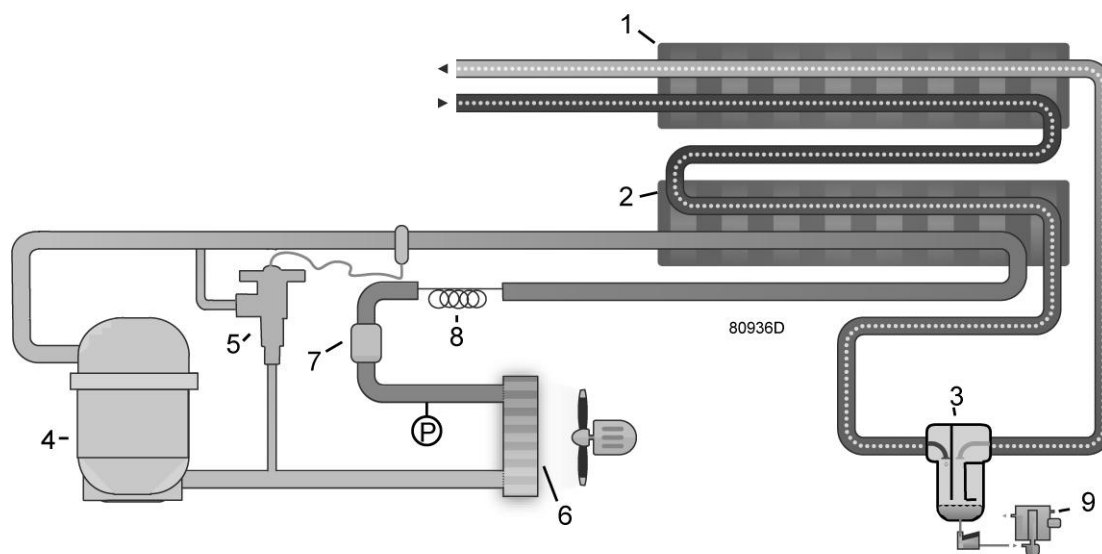

Compressed air enters the heat exchanger (1) and is cooled by the outgoing, cold, dried air. Water in the incoming air starts to condense. The air then flows through the evaporator heat exchanger (2) where the refrigerant evaporates, causing the compressed air to be cooled further to close to the evaporating temperature of the refrigerant. More water in the air condenses. The cold air then flows through water separator (3), where the condensate is separated from the air. The condensate is automatically drained by the electronic condensate drain (9).

The cold, dried air flows through heat exchanger (1) where it is warmed up by the incoming air.

Refrigerant circuit

Compressor (4) delivers hot, high-pressure refrigerant gas which flows through the condenser (6) where most of the refrigerant condenses.

Next, the liquid refrigerant flows through dryer/filter (7) to capillary tube (8). The refrigerant leaves the capillary tube at evaporating pressure.

The refrigerant enters the evaporator (2) where it withdraws heat from the compressed air by further evaporation at constant pressure. The heated refrigerant leaves the evaporator and is sucked in again by the compressor.

The condenser (6) pressure must be kept as constant as possible to obtain stable operation. Fan control switch (P) therefore stops and starts the condenser cooling fan. If, under partial or no load, the evaporator (2) pressure drops to approximately 2.25 bar(e) (32.63 psig), the hot gas bypass valve (5) opens and hot, high-pressure gas is fed to the evaporator circuit to prevent the evaporator pressure from dropping any further.

Electronic condensate drain

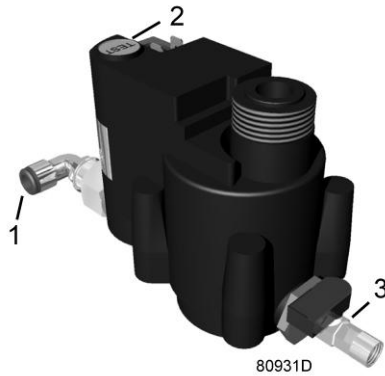

The dryer is equipped with an electronic condensate drain. The condensate, separated by the condensate trap, accumulates inside the drain. Once the condensate reaches a certain level, it is discharged through the drain outlet (1).

The condensate can also be drained by pressing the test button (2).

The drain filter can be cleaned by opening the manual drain valve (3), see section [Preventive maintenance schedule](#).

3 Installation

3.1 Dimension drawings

The dimension drawings can be found in the technical documentation, supplied with the compressor.

| Model | Dimension drawing number |
|------------------------------|--------------------------|
| SF 1-6 P FM EP metric | 9820 6376 02-01 |
| SF 1-6 P FM EP imperial | 9820 6376 02-04 |
| SF 1-6 FF FM EP metric | 9820 6376 03-01 |
| SF 1-6 FF FM EP imperial | 9820 6376 03-04 |
| SF 1-6 P TM EP metric | 9820 6376 04-01 |
| SF 1-6 P TM EP imperial | 9820 6376 04-04 |
| SF 1-6 FF TM EP metric | 9820 6376 05-01 |
| SF 1-6 FF TM EP imperial | 9820 6376 05-04 |
| SF 1-6 P-FF 30 I EP metric | 9820 6376 06-01 |
| SF 1-6 P-FF 30 I EP imperial | 9820 6376 06-04 |

Legend

| | | | |
|------|-----------------------------------|----|-----------------------------------|
| P | Without refrigerant dryer | FF | With integrated refrigerant dryer |
| FM | Floor-mounted | TM | On air receiver |
| 30 I | With integrated 30 I air receiver | EP | Electro-pneumatic control |
| CD | With CD dryer | EL | With Elektronikon™ controller |

Hereby a list of commonly used terms with their translation:

| Text on drawings | Translation or Explanation |
|------------------------------------|--|
| COOLING AIR OUTLET | Cooling air outlet |
| COMPRESSED AIR OUTLET | Compressed air outlet |
| COOLING AIR INLET | Cooling air inlet |
| POWER SUPPLY CABLE | Power supply cable |
| DRYER MANUAL DRAIN | Manual drain valve of the dryer |
| AUTOMATIC DRAIN | Automatic drain outlet |
| CENTER OF GRAVITY | Location of center of gravity |
| DRYER SERVICE PANEL | Service panel for the dryer |
| DOOR FULLY OPEN | Dimensions with fully open door |
| COOLING AIR INLET OF DRYER | Cooling air inlet for the dryer |
| ANCHOR POINTS | Location of anchoring points |
| AIR RECEIVER MANUAL DRAIN | Manual drain of the air receiver |
| THE DIMENSIONS FOR 500 L VESSEL... | Dimensions of the 500 l vessel are indicated between () where they are different from the dimensions of the 270 l vessel. |

| | |
|---|--|
| Text on drawings | Translation or Explanation |
| THE DIMENSIONS FOR FULL-FEATURE UNIT... | Dimensions of the Full-Feature units are indicated between () |

3.2 Installation proposal

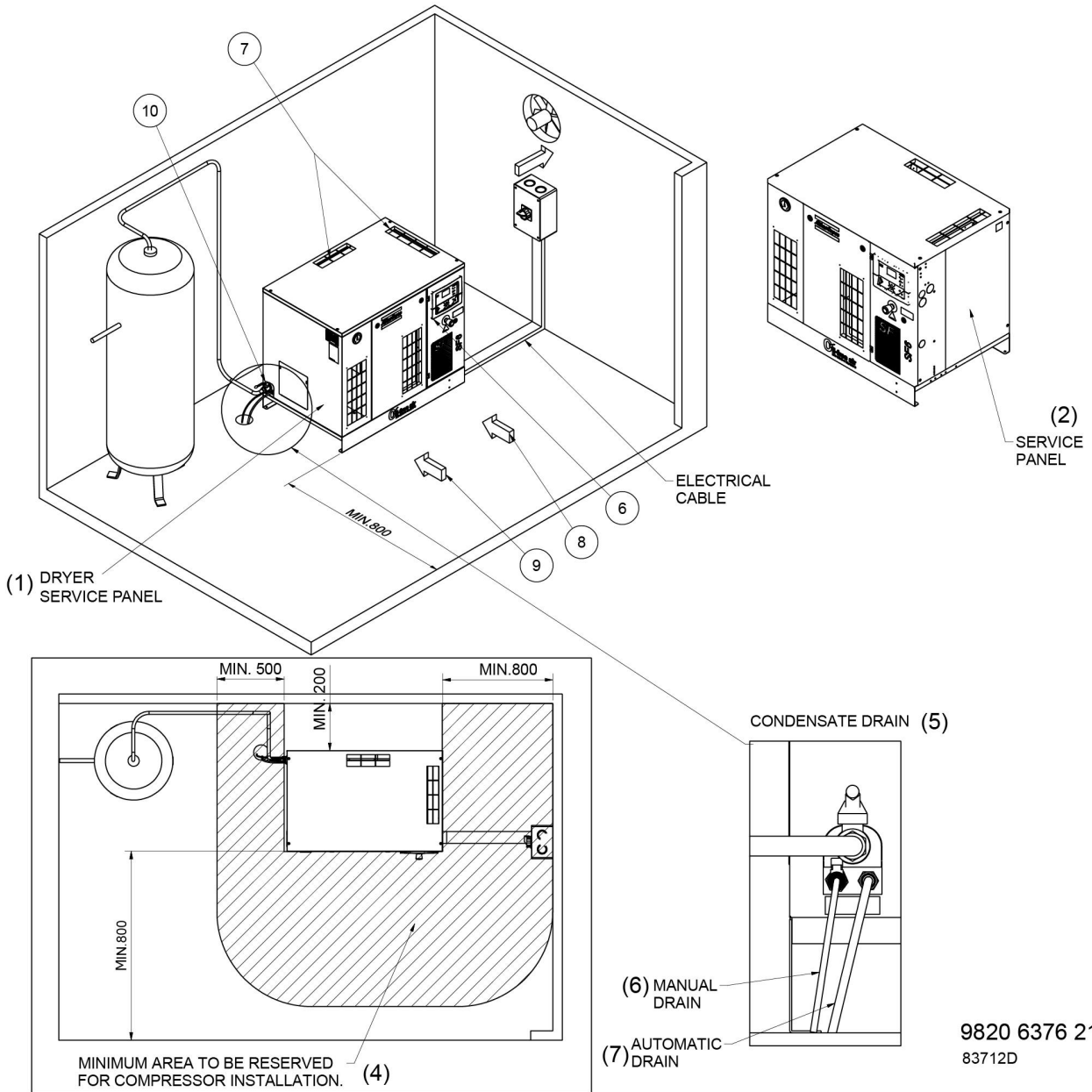

9820 6376 21
83712D

| | | | |
|---|--|---|------------------|
| 1 | Dryer service panel | 5 | Condensate drain |
| 2 | Service panel | 6 | Manual drain |
| 3 | Supply cable | 7 | Automatic drain |
| 4 | Minimum area to be reserved for servicing purposes | | |

Recommendations

1. Install the compressor on a level horizontal industrial floor, suitable for taking the weight of the compressor. The compressor unit must be installed on a level floor.
It is mandatory to remove the shipment pallet to install the compressor correctly.
The location must be frost-free and preferably low dust location.
2. Delivery pipe. The pressure drop in the delivery pipe can be calculated from:

$$\Delta p = (L \times 450 \times Q_c^{1.85}) / (d^5 \times P)$$
, with
 d = inner diameter of the pipe in mm
 Δp = pressure drop in bar (recommended maximum: 0.1 bar (1.5 psi))
 L = length of the pipe in m
 P = absolute pressure at the compressor outlet in bar
 Q_c = free air delivery of the compressor in l/s
3. Ventilation: the inlet grids and ventilation fan should be installed in such a way that any recirculation of cooling air to the compressor is avoided. The maximum air velocity through the grids is 5 m/s (16.5 ft/s). The maximum allowable pressure drop over the cooling air ducts is 30 Pa (0.12 in wc). The maximum air temperature at the compressor intake opening is 40 °C (104 °F).

Take care that the temperature of the ambient air and the cooling air may never be lower than 0 °C (32 °F) to avoid freezing of condensate.

The required ventilation capacity to limit the compressor room temperature can be calculated from:

- $Q_v = 1.06 N/\Delta t$ for compressors without integrated dryer.
- $Q_v = (1.06 N + 0.2)/\Delta t$ for compressors with integrated dryer.

with

Q_v = required ventilation capacity in m³/s

N = shaft input of the compressor in kW

Δt = temperature increase in the compressor room in °C

4. Air receiver: an optional air receiver can be necessary to limit the cycle frequency.
Recommended maximum is 20 starts per hour.
5. **Optional filters can be installed in the pressure line downstream the air outlet valve, e.g.:**
 - A DD⁺ filter for general purpose filtration. The filter traps solid particles down to 1 micron.
 - A PD⁺ filter for filtration down to 0.01 micron. A PD filter must always be installed downstream a DD filter.
6. Control cubicle with monitoring panel.
7. Compressor and dryer cooling air outlet
8. Compressor cooling air inlet
9. Refrigerant dryer cooling air inlet
10. Connect condensate drain outlet to a sewer. It is recommended to provide a funnel to allow visual inspection of the condensate flow. If the condensate piping has been led outside the compressor room where it may be exposed to freezing temperatures, the piping must be insulated. The condensate drain pipe from the compressor to the sewer must not dip into the water of the sewer.
11. All piping to be connected free of stress.
12. A remote air intake is available as an option. For more information on the maximum pipe length, please contact Atlas Copco.

3.3 Electrical connections

Attention

| | |
|--|--|
| | <p>The electrical installation must correspond to the applicable codes. The mains supply and earthing lines must be of suitable size.</p> <p>The installation must be earthed and protected by fuses in each phase. Install an isolating switch near the compressor.</p> <p>Make sure that this switch is open to isolate the compressor from the mains before carrying out any connection.</p> |
|--|--|

Supply cable

Consult section [Cable size](#) for the section of the power supply cable.

An electric cable is provided on the unit. Fit a suitable plug on the cable.

Plug in the cable.

Three voltage units

The compressors leave the factory wired for 230 V. If the compressor is to be used on 460 V, rewire the motor as follows:

1. Take all necessary precautions.
2. Change the connection in the motor terminal box according following instructions:
 - For SF 2, SF 2+, SF 4 and SF 4+:

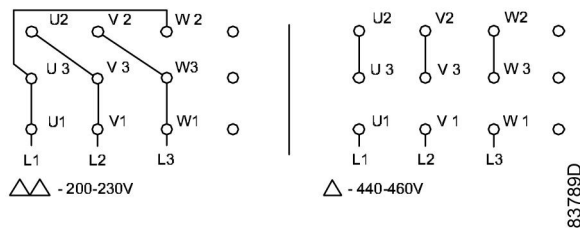

- For SF 6 and SF 6+:

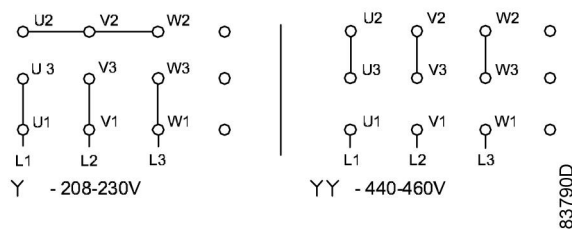

3. Change also the voltage connection on auxiliary transformer T1.
4. Replace the fuses.
5. Adjust the overload relay settings (see section [Settings of overload relay and fuses](#)).

3.4 Pictographs

Pictographs

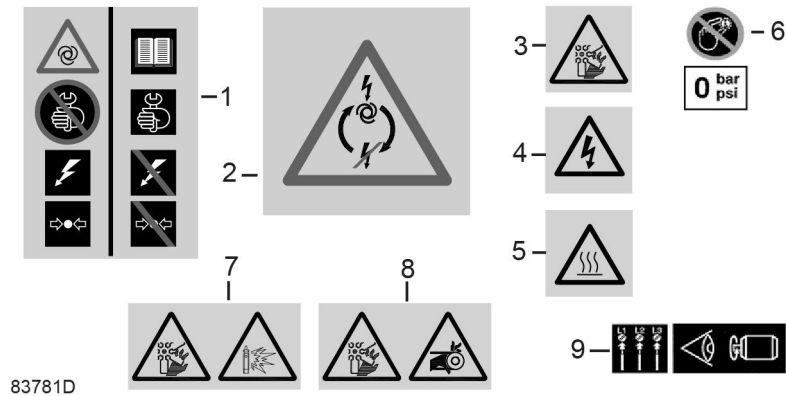

| Reference | Explanation |
|-----------|--|
| 1 | Warning: the compressor starts and stops automatically. Do not perform service when pressurized and when the voltage is on. Read the instruction book, switch off the power and depressurize the compressor before maintenance or repair. |
| 2 | After power failure during automatic operation, the unit restarts automatically. |
| 3 | Warning: rotating fan |
| 4 | Warning: supply voltage |
| 5 | Warning: hot surface |
| 6 | Do not adjust the pressure switch while it is depressurized because this can damage the switch (only for compressors controlled by a pressure switch). |
| 7 | Warning: rotating fan Warning: safety valve blowing |
| 8 | Warning: rotating fan Warning: belts |
| 9 | Warning: before connecting compressor electrically, consult the instruction book for motor rotation direction. |

Alternative for label 1:

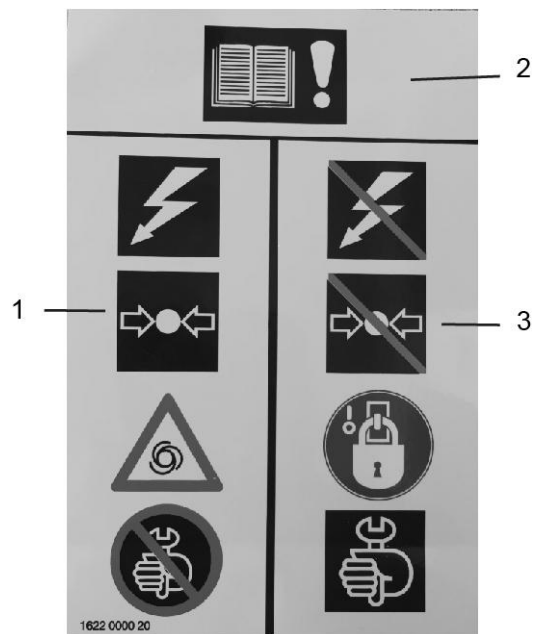

| Reference | Explanation |
|-----------|--|
| 1 | Do not work on the compressor when the unit is running, under pressure or in automatic operation. |
| 2 | Always read the instruction book first. |
| 3 | Switch off the voltage, release the pressure and prevent the unit is switched on inadvertently (Lock out/Tag out) before working on the equipment. |

4 Operation

4.1 Initial start-up

Safety



The operator must apply all relevant [Safety precautions during operation](#).



The maximum recommended motor starting frequency is 20 starts per hour. In order to keep the number of starts at an acceptable level, the compressor must be connected to an air receiver with a suitable size.

Initial start-up

1. Remove the red painted transport brackets.

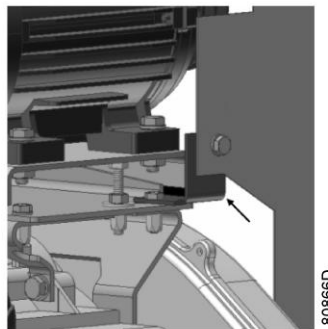

2. Close the air outlet valve (AV - see section [Introduction](#)).
3. Check the settings of overload relay (F21 - see section [Settings of overload relay and fuses](#)).
Check the drive motor connections. Connect the compressor to the electricity net.
4. Close the condensate drain valve(s). See sections [Introduction](#) and [Flow diagram](#) for their location.
5. Switch on the voltage. Lamp (H1) alights.
Start the compressor and stop it immediately by means of switch Q1 (see section [Introduction](#)).
On 3-phase units, check the rotation direction of drive motor. For this purpose, a sheet with start-up instructions is fitted to the outlet grating. When the rotation direction is correct, the paper will be blown upwards. If the direction is wrong, stop the compressor immediately and reverse two incoming electric lines.

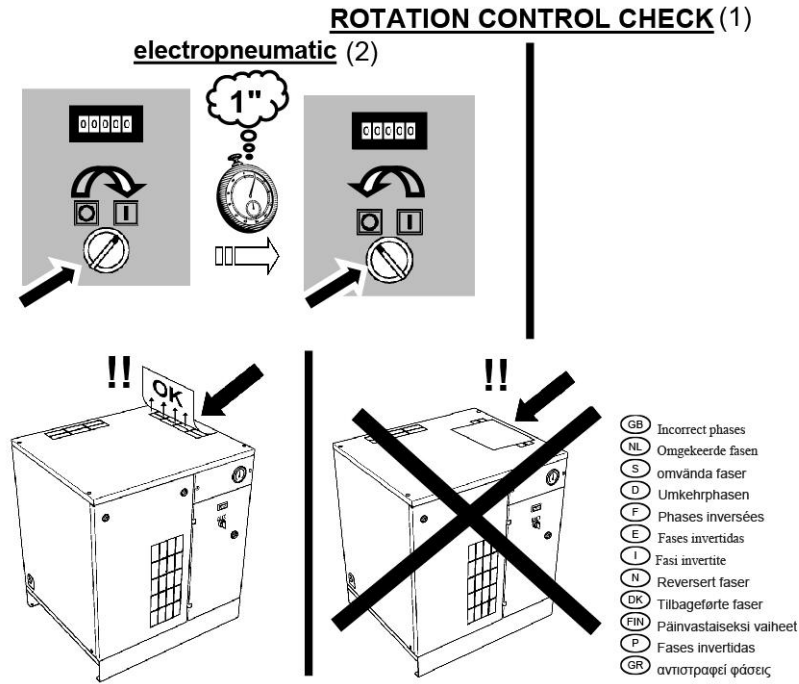

84500D

| | |
|-----|---|
| (1) | Rotation control check |
| (2) | Electropneumatic controlled compressors |

A compressor equipped with a phase sequence relay will not start if the phase sequence is wrong. In that case, reverse two incoming electric lines to solve the issue.

4.2 Starting

Control panel

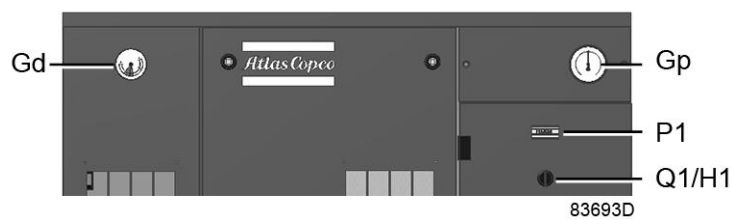

| | | | |
|----|----------------|-------|-------------------------|
| Gp | Pressure gauge | Q1/H1 | On/off switch with lamp |
| P1 | Hour meter | Gd | Dew point gauge |

Procedure

1. Close the manual condensate drain valve(s) if present.
2. Open the air outlet valve (AV).
3. Switch on the voltage. Lamp (H1) alights.
4. Rotate switch (Q1) to position I.
5. The motor starts and stops automatically depending on the air pressure.

- On compressors equipped with a refrigerant dryer, the dew point of the refrigerant dryer will be reached after a few minutes.

4.3 During operation

Procedure

- Check the pressure gauge (Gp) on the control panel to check the pressure setting.
- On compressors with a built-in refrigerant dryer, check also the temperature gauge (Gd) on the control panel to check the dew point.
Check that condensate is discharged regularly by the automatic drain of the dryer. The amount of condensate depends on the operating conditions of the unit and the humidity of the air.
Open the manual drain valve from time to time to remove eventual impurities (see also section [Preventive maintenance schedule](#)).
- On receiver mounted compressors, open the manual drain valve of the air receiver regularly to remove the water (specially in case of compressors without dryer). See also section [Preventive maintenance schedule](#).



The dew point will deviate from nominal when the nominal conditions are exceeded. If the dew point remains too high or unstable, consult section [Problem solving](#).

4.4 Stopping

Control panel

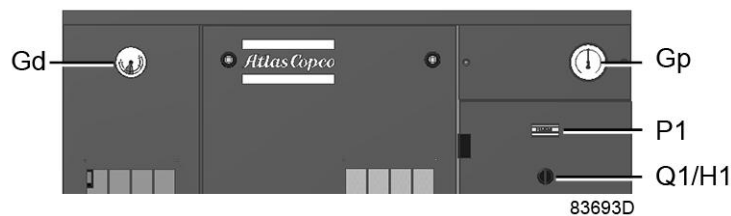

| | | | |
|----|----------------|-------|-------------------------|
| Gp | Pressure gauge | Q1/H1 | On/off switch with lamp |
| P1 | Hour meter | Gd | Dew point gauge |

Procedure

- Rotate switch (Q1) to position O. The compressor stops.
- Switch off the voltage.
- Close air outlet valve (AV - see section Introduction).



The refrigerant air dryer and the air receiver remain under pressure. If it is necessary to depressurize, open the manual drain valve(s).

4.5 Taking out of operation

Procedure

1. Stop the compressor and close the air outlet valve.
2. Switch off the voltage and disconnect the compressor from the mains.
3. Depressurize the compressor.
On compressors with refrigerant dryer and on compressors with an air receiver, open the manual drain valve(s) (Dm / Dm1).
4. If provided, shut off and depressurize the part of the air net which is connected to the outlet valve. Disconnect the compressor from the air net.
5. If provided, disconnect the compressor condensate piping from the local condensate drain system.
6. Before moving the unit, reinstall the red transport brackets.

5 Preventive maintenance

5.1 Preventive maintenance schedule

| | |
|---|---|
|  | <p>Before carrying out any maintenance, repair work or adjustments, proceed as follows:</p> <ul style="list-style-type: none"> • Stop the compressor. • Switch off the voltage and open the isolating switch. • Close the air outlet valve. • Depressurize the compressor by opening the manual drain valve(s). <p>The operator must apply all relevant Safety precautions during maintenance or repair.</p> |
|---|---|

Warranty - Product Liability

Use only authorized parts.

Any damage or malfunction caused by bad maintenance is not covered by Warranty or Product Liability.

General

When servicing, replace all removed gaskets, O-rings and washers. Clean parts when reused.

Intervals

The local Customer Center may overrule the specified maintenance schedule, especially the service intervals, depending on the environmental and working conditions of the compressor.

| | |
|---|---|
|  | <p>The longer interval checks and actions must also include the shorter interval checks.</p> |
|---|---|

Preventive maintenance schedule

| Period (note 1) | Running hours (note 1) | Operation |
|-------------------------|------------------------|---|
| Daily | -- | <ul style="list-style-type: none"> • Check readings on the display. • Compressors with integrated air receiver and/or compressors with integrated refrigerant dryer: Check if condensate is discharged regularly. • Tank-mounted compressors: Drain the condensate manually at the end of the day. • Compressors with integrated dryer: Check the dew point. |
| Every 3 months (note 2) | 500 | <p>Inspect the air inlet filter(s) (AF). Inspect the prefilter mats on the cooling air intake openings (if fitted). Check for cleanness and damage. Clean if dirty, replace if damaged. Clean the compressor and check the air cooler . If necessary, clean by air jet. After the first 500 running hours or when the belt has been replaced, check the belt tension and adjust if necessary according to the information on the label.</p> |

| Period (note 1) | Running hours (note 1) | Operation |
|-------------------------|------------------------|--|
| Every 6 months | -- | <ul style="list-style-type: none"> Manually operate the safety valve. Check for any damaged wiring or loose connections. Check for air leaks. |
| Every 6 months (note 2) | -- | <p>Compressors with integrated dryer:</p> <ul style="list-style-type: none"> If dirty, brush or blow off the finned surface of the dryer's condenser. Inspect and clean the electronic drain: <ul style="list-style-type: none"> Functioning of the drain can be checked by pushing the TEST button of the drain. Cleaning of the drain filter can be done by opening the manual drain valve during a few seconds. |
| Yearly | 2500 | <ul style="list-style-type: none"> Replace the air inlet filter(s) (AF) and the prefilter mats on the cooling air intake openings (if fitted) (note 2). Test the safety valve. Have temperature protection and motor overload tested. Check tension and condition of the V-belt(s). |
| Every 2 years | 5000 | <ul style="list-style-type: none"> Replace the V-belt(s). Replace check valve. |
| Every 2 years | 5000 | <p>8 bar and 116 psi compressors: Have the orbiting scroll bearing greased (see note 3).</p> |
| Every 2 years | 5000 | <p>10 bar and 145 psi compressors:</p> <ul style="list-style-type: none"> Replace the element outlet pipe and the plastic insert (only on SF 1, SF 2 and SF 4). See section Outlet pipe replacement. Note: From S/N API 744 000 onwards, a new version of compressor element is used on SF 4. This new element no longer has a plastic insert in the outlet pipe and preventive replacement is no longer required. Clean fan (FN1 - see Flow diagram), fan duct and element cooling fins (see note 2). Clean the motor fan grid. Have orbiting scroll bearing and pin crank bearings greased (see note 3). Replace tip seals and dust seal (see also note 4). |
| Every 4 years | 10000 | <p>8 bar and 116 psi compressors:</p> <ul style="list-style-type: none"> Replace the element outlet pipe and the plastic insert (only on SF 1, SF 2 and SF 4). See section Outlet pipe replacement. Note: From S/N API 744 000 onwards, a new version of compressor element is used on SF 4. This new element no longer has a plastic insert in the outlet pipe and preventive replacement is no longer required. Clean fan (FN1 - see Flow diagram), fan duct and element cooling fins (see note 2). Have orbiting scroll bearing and pin crank bearings greased (see note 3). Replace tip seals and dust seal (see also note 4). |

Notes:

- Maintenance must be done according to the number of running hours or according to the running period, whichever comes first.
- More frequently in a dusty environment.
- Important note:** Greasing of the bearings of the compressor element must be done with **special grease**, a **special grease gun**, and according to a **specific procedure**.

In high ambient conditions, the bearings must be greased more frequently: for every 5 °C (9 °F) increase above 30 °C (86 °F), the maintenance interval should be reduced with 30 %.

Contact your supplier for details.

4. In extremely dry conditions (relative humidity below 15 %), the tip seals and dust seals need to be replaced more frequently.

5.2 Service kits

Service kits

For overhauling and for preventive maintenance, a wide range of service kits is available. Service kits comprise all parts required for servicing the component and offer the benefits of genuine parts while keeping the maintenance budget low.

Consult the Spare Parts List for part numbers.

6 Adjustments and servicing procedures

6.1 Pressure switch

Description

The pressure switch (PS - see section [Flow diagram](#)) determines the operating pressure of the compressor. The stopping and starting pressures are the opening and closing pressures of the switch.



Adjustments may only be carried out when the switch is pressurized.

Pressure switch

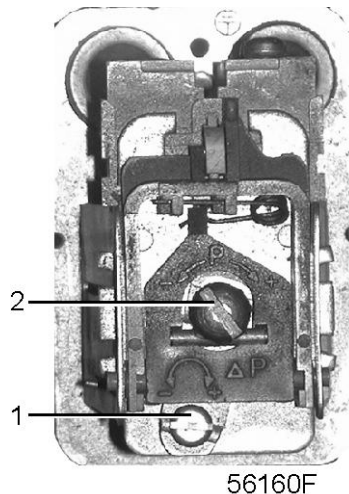

The stopping pressure is controlled by adjusting screw (2). Turn the screw clockwise to raise the stopping pressure, anti-clockwise to lower it.

The pressure difference between starting and stopping is adjusted by means of adjusting screw (1). Turn the screw anti-clockwise to reduce the pressure difference, clockwise to increase it.

Adjustment range

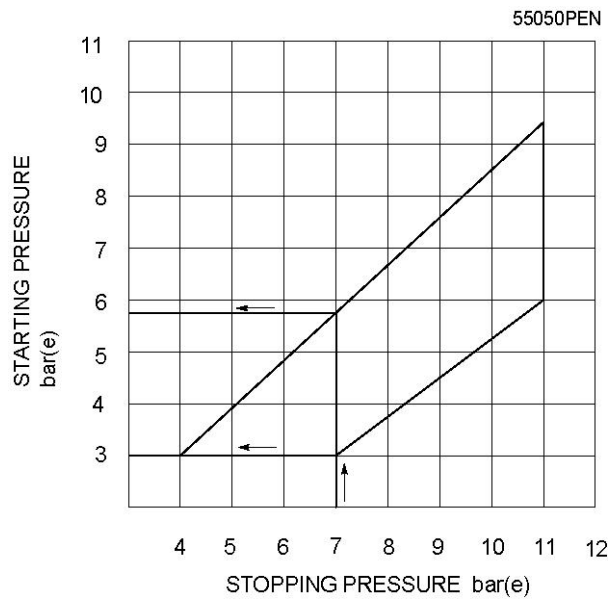

Example:

Stopping pressure: 7 bar(e) (100 psig)

Starting pressure: adjustable between 5.8 bar(e) (84 psig) and 3 bar(e) (43.5 psig)

8 bar (116 psi) units: the pressure switch is factory-adjusted to start the compressor at 6.5 bar(e) (94 psig) and to stop at 7.75 bar(e) (112 psig).

10 bar (145 psi) units: the pressure switch is factory-adjusted to start the compressor at 8 bar(e) (116 psig) and to stop at 9.75 bar(e) (141 psig).

6.2 Air filter

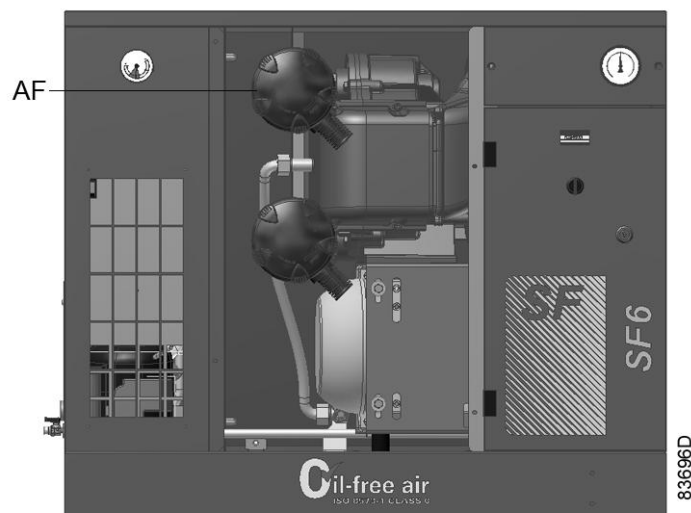

Air filter (AF)

Procedure

1. Stop the compressor, close the air outlet valve and switch off the voltage.
2. Remove the filter cover and the filter element. Discard damaged or clogged elements. Clean the cover.
3. Fit the new element and reinstall the filter cover.

SF 6 has 2 air filters.

6.3 Air cooler

Cleaning

Keep the cooler clean to maintain cooling efficiency. If necessary, remove any dirt with a fibre brush. Never use a wire brush or metal objects.

Next, clean by air jet in reverse direction of normal flow.

If it is necessary to wash the cooler with a cleansing agent, consult Atlas Copco.

6.4 Drive motor

Instructions

The motor bearings are greased for life and do not require special attention.

Keep the motor free from dust for optimal cooling.

6.5 Safety valve

Testing

| | |
|---|--|
|  | Testing shall only be carried out by competent personnel |
|---|--|

1. Stop the compressor, close the air outlet valve and switch off the voltage.
2. Depressurize the compressor.
3. Remove the safety valve. See section [Introduction](#) for the location of the safety valve (SV).
4. Test the safety valve on a separate compressed air circuit by gradually increasing the pressure. If the safety valve does not open at the specified pressure, it must be replaced. See section [Temperature protection and safety valve settings](#) for the opening pressure of the safety valve.

| | |
|---|---|
|  | No adjustments are allowed. Never run the compressor without a safety valve. |
|---|---|

6.6 Belt replacement

Procedure



If more than one belt is used, the belts must be replaced as a set, even if only one of them seems worn.
Use Atlas Copco belts only. The number of the belt set is mentioned in the Parts list.

1. Remove the service panel (S).

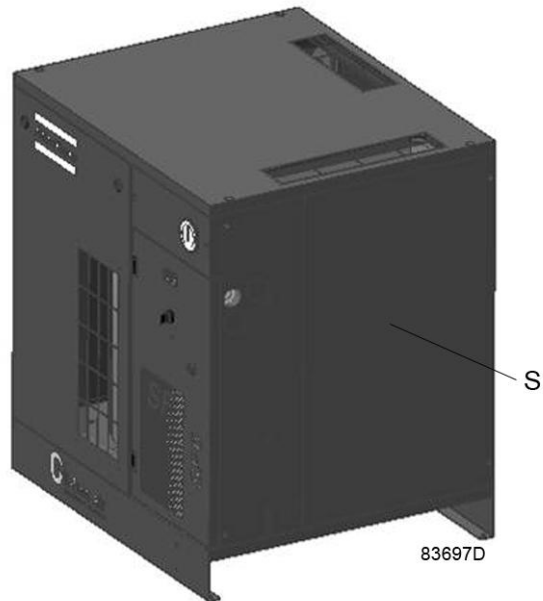

2. Loosen screw (A).

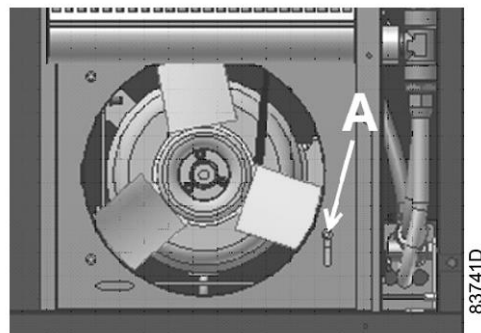

3. Remove the front panel.
4. Remove the inlet baffle (I)

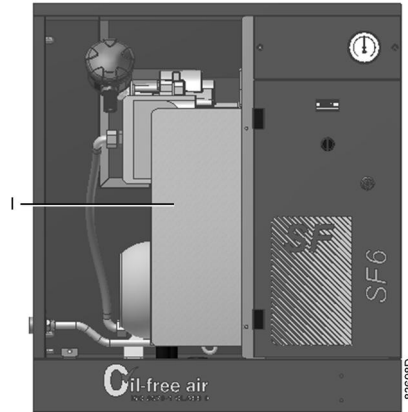

5. Loosen screws (B).

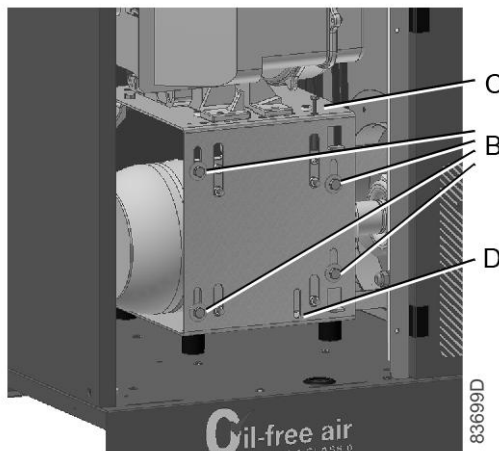

- 6. Loosen screw (C).
- 7. Use slot (D) to lift the motor plate.
- 8. Install the new belt(s) in the pulley grooves.
- 9. Set the tension of the belt(s) by screwing bolt (C) out. Refer to the label on the motor plate for tensioning data:

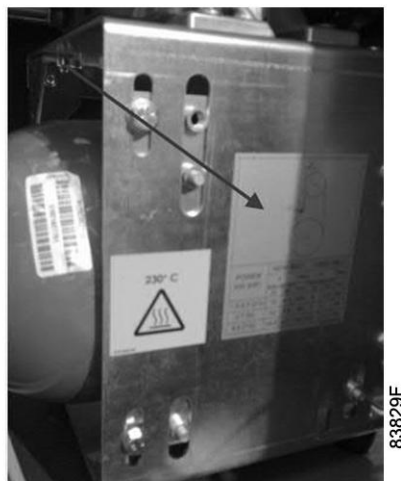

- 10. Tighten screws (B). Reinstall the inlet baffle.
- 11. Check the belt tension after the first 500 running hours.

6.7 Temperature protection

Description

The scroll element is protected by a temperature switch.

The switch monitors the temperature of the compressor element.

The switch shuts down the compressor in case of overheating. After cooling down, the switch automatically resets itself.

No adjustment is possible.



- When the compressor is stopped due to overheating, be aware that the compressor will restart automatically after cooling down. **Therefore, always switch off the power before starting maintenance or repair activities.**
- Never run the compressor without the temperature switch.

6.8 Cleaning the compressor element



- Compressor element cooling channels can be hot when the compressor has just been turned off.
- Do not clean the cooling channels with organic solvent since this will damage the surface treatment.

The purpose of cleaning the cooling channels of a scroll element is to prevent the cooling channels to silt up and as such reduce the cooling efficiency. A reduced cooling efficiency can lead towards a premature compressor element failure.

Procedure:

1. Stop the compressor and switch off the power.
2. Close the air outlet valve and depressurise the compressor.
3. Remove the fan duct:
 - Unscrew the 3 bolts (1).
 - Remove clip (2) (if applicable).

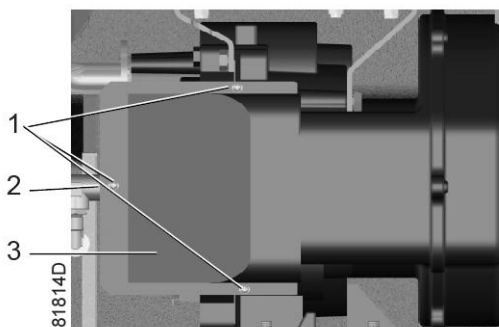

- Remove fan duct (3).
4. Clean cooling channels:
 - Remove dust from the cooling channels (1) by means of air jet (see next figure).
 - Clean the fan duct (2).

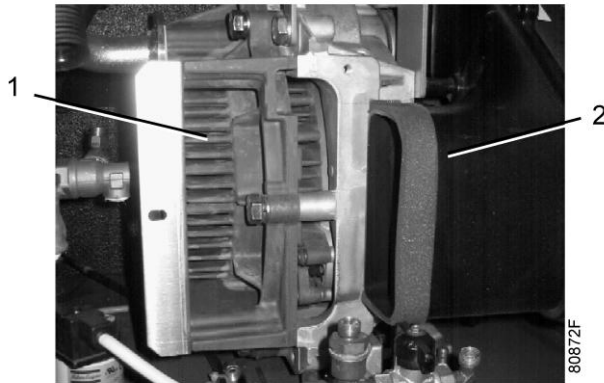

5. Reassemble the fan duct:
- Put the fan duct in place.
 - Fit the 3 bolts and the clip.

The unit is now again ready for use.

6.9 Replacement of the outlet pipe

Description

The outlet pipe (1) of the 2.2 kW compressor element (used on SF 1 and SF 2) and of the 3.7 kW element (used on SF 4 up to S/N API 744 000) contains a plastic insert (3).

Due to the heat of the compressed air, the plastic insert may become brittle after time. It is recommended to replace the outlet pipe together with the insert when that is the case. Both parts are available as a kit (outlet pipe set). Consult the Spare Parts List for part numbers.

The outlet pipe set contains two parts:

- The plastic insert (3)
- The metal outlet pipe (1)

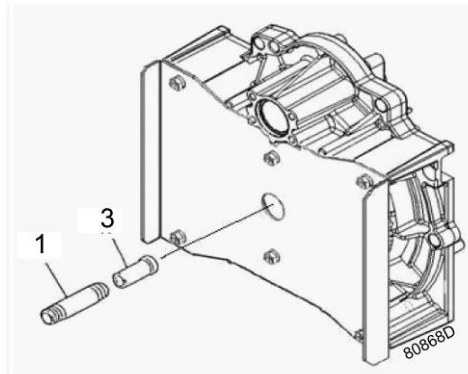

Replacement procedure

1. Stop the compressor, depressurize and switch off the voltage.
2. Loosen coupling (3) while immobilizing nipple (2) with a wrench.

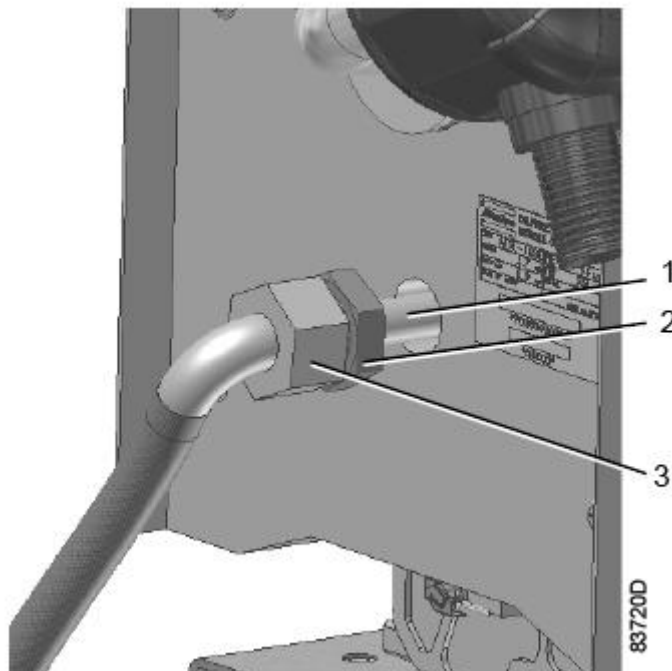

3. Remove the outlet pipe together with the nipple.
4. Fit the nipple to the new outlet pipe and tighten. Use only PTFE tape.
5. Fit the plastic insert in place as indicated on the drawing and assemble the outlet pipe with a maximum torque of 5 Nm (3.7 lbf.ft). Maximum one extra turn (360 °) is allowed for positioning of the elbow. Do not end turning counterclockwise in order to avoid leaks. Use only PTFE tape.

Warning: If the outlet pipe is tightened too hard, the thread of the element can get damaged or the insert can break, resulting in overheating of the compressor element! The maximum torque is 40Nm (29.5 lbf.ft).

6. Fasten coupling (3) while holding nipple (2) with a wrench.

Remark:

The outlet pipe of the new version of the 3.7 kW element (used on SF 4 from S/N API 744 000 onwards) and of the 5.5 kW element (used on SF 6) does not contain an insert. In case of disassembly, please apply the same assembly procedure as described above. Maximum torque: 15 Nm (hand tight plus maximum 2 revolutions).

6.10 Refrigerant dryer maintenance

Safety precautions

The dryer circuit contains refrigerant. **When handling refrigerant, all applicable [Safety precautions during maintenance or repair](#) must be observed. Specifically be aware of following points:**

- Contact of liquid refrigerant with the skin can cause freezing. Wear special gloves. If contacted with the skin, the skin should be rinsed with water. On no account may clothing be removed.
- Fluid refrigerant can also cause freezing of the eyes. Wear safety glasses.
- Avoid inhalation of refrigerant vapors. Check that the working area is adequately ventilated.

Be aware that internal components of the dryer such as the pipes can reach a temperature of up to 110°C (230°F). Therefore, wait until the dryer has cooled down before removing the side panels.

Before starting any maintenance or repair work, switch off the voltage and close the air outlet valve.

Local legislation

Local legislation may stipulate that:

- Work on the refrigerant circuit of the cooling dryer or on any equipment which influences its function must be undertaken by an authorized control body.
- The installation should be checked once a year by an authorized control body.

General

The following remarks should be kept in mind:

- Keep the dryer clean.
- Brush or blow off the finned surface of condenser regularly.
- Inspect and clean the electronic condensate drain regularly.
 - a. Functioning of the drain can be checked by pushing the TEST button of the drain, consult section Air dryer.
 - b. Cleaning of the drain filter can be done by opening the manual drain valve during a few seconds.

Device settings

The regulating and safety devices are factory adjusted to obtain optimum performance of the dryer. Do not alter the setting of any of the devices.



Connecting pressure measuring devices in the refrigerant circuit can change the amount of refrigerant in the system. This results in a less optimal working of the dryer.

7 Problem solving



Before carrying out any maintenance or repair, perform the following steps:

- Stop the compressor and switch off the voltage.
- Open and lock the isolating switch to prevent an accidental start.
- Isolate the compressor by closing the outlet valve.
- Depressurize the system by opening the drain valve(s).

Compressor

| Condition | Fault | Remedy |
|--|--|--|
| The compressor does not start. | Pressure too high. | Compressor will start again when the pressure drops to the starting pressure. |
| | On/off switch (Q1) malfunctioning or loose connection | Have electrical connections checked. Test switch. Replace if necessary. |
| | Thermal overload of switch (Q1) | Restart after cooling down. |
| | Switch (TSHH) open or motor protection relay (F21) tripped | Wait for switch to cool down. Replace switch if necessary. Reset overload relay (F21). |
| | Air pressure switch (PS) out of order | Test switch, replace if necessary. |
| The compressor does not stop and/or safety valve blows. | Air pressure switch (PS) opens too late or not at all. | Readjust switch, replace if necessary. |
| | Safety valve (SV) opens too soon. | Have valve replaced. |
| Pressure difference between stopping and starting cannot be adjusted | Air pressure switch (PS) out of order | Replace if necessary. |
| Compressor capacity or pressure below normal | Air consumption exceeds capacity of compressor. | Check equipment connected. |
| | Choked air filter | Remove and check filter. Replace if necessary. |
| | Safety valve leaking | Replace valve. |
| | Drive belts slipping. | Check condition of belts and belt tension. Correct or replace as required. |
| | Compressor element out of order | Consult the supplier. |
| Compressor overheating and/or shut-down by air temperature switch (TSHH) | Insufficient compressor cooling | Clean compressor element fins and fan, see section Cleaning . Improve ventilation of compressor room, see section Installation proposal . Reset overload relay (F21) if necessary. |
| | Cooling fans (FN1 and FN2) out of order. | Check and correct, reset overload relay (F21) if necessary. |
| | Temperature shutdown switch out of order. | Replace switch. |

Refrigerant dryer

For compressors with a built-in refrigerant dryer also:

| Condition | Fault | Remedy |
|---|---|---|
| Dew point too high | Air inlet temperature too high | Check and correct; see section Reference conditions and limitations . |
| | Fuses blown | Check fuses and remedy the cause. |
| | Shortage of refrigerant | Have circuit repaired or recharged. |
| | Refrigerant compressor does not run | See below |
| | Evaporator pressure is too high | See below |
| | Condenser pressure is too high | See below |
| Condenser pressure too high or too low | Fan control switch out of order | Have switch replaced. |
| | Condenser fan motor out of order | Have fan motor inspected. |
| | Ambient temperature too high | Improve ventilation of compressor room, see section Installation proposal . |
| | Condenser externally clogged | Clean condenser |
| Motor of refrigerant compressor stops or does not start | The internal thermal protection of the motor has tripped | Compressor will restart when the motor windings have cooled down. |
| | Electric power supply to refrigerant compressor interrupted | Check and correct as necessary. |
| Evaporator pressure is too high or too low | Condenser pressure too high or too low | See above |
| | Shortage of refrigerant | Have circuit repaired or recharged. |
| | Hot gas bypass valve incorrectly set or out of order | Have the valve adjusted or replaced. |
| Condensate trap continuously discharging air and water | Automatic drain out of order | Have the drain checked. Replace as necessary. |
| Electronic condensate drain inoperative | Drain system clogged | Clean the filter of the automatic drain by opening the manual drain valve. Check the functioning of the drain by pushing the test button. |

8 Technical data

8.1 Readings on control panel

Description



The readings mentioned below are valid under the reference conditions (see section [Reference conditions and limitations](#)).



| | |
|-------|---|
| Gp | Air outlet pressure Reading: modulates between preset starting pressure and stopping pressure. See section Pressure switch . |
| Gd | Dew point temperature Reading: approx. 2 - 5 °C (35 - 41 °F). See section Compressor data . |
| P1 | Hour meter Reading: total running time |
| Q1/H1 | On/off switch with lamp |

8.2 Electric cable size

Attention



Local regulations remain applicable if they are stricter than the values proposed below. The voltage drop must not exceed 5% of the nominal voltage. It may be necessary to use cables of a larger size than those stated to comply with this requirement.

Cable size

| | | SF 1 | SF 2 | SF 4 | SF 6 |
|-----------|--------------|-------------------|---------------------|---------------------|---------------------|
| Frequency | Voltage | Cable size | Cable size | Cable size | Cable size |
| IEC | | | | | |
| 50 Hz | 200 V 3~ | -- | -- | 6 mm ² | 6 mm ² |
| 50 Hz | 230 V 1~ | 4 mm ² | 6 mm ² | -- | -- |
| 50 Hz | 230 V 3~ | -- | 4 mm ² | 6 mm ² | 6 mm ² |
| 50 Hz | 400 V 3~ | -- | 1.5 mm ² | 1.5 mm ² | 2.5 mm ² |
| 50 Hz | 400 V 3~ + N | -- | 1.5 mm ² | 1.5 mm ² | 2.5 mm ² |

| | | SF 1 | SF 2 | SF 4 | SF 6 |
|-----------|----------|------------|---------------------|---------------------|---------------------|
| Frequency | Voltage | Cable size | Cable size | Cable size | Cable size |
| 60 Hz | 380 V 3~ | -- | 1.5 mm ² | 1.5 mm ² | 2.5 mm ² |
| UL/CUL | | | | | |
| 60 Hz | 200 V 3~ | -- | AWG 12 | AWG 10 | AWG 8 |
| 60 Hz | 230 V 1~ | AWG 10 | -- | -- | -- |
| 60 Hz | 230 V 3~ | -- | AWG 12 | AWG 10 | AWG 8 |
| 60 Hz | 460 V 3~ | -- | AWG 12 | AWG 10 | AWG 8 |
| 60 Hz | 575 V 3~ | -- | AWG 14 | AWG 14 | AWG 14 |

8.3 Settings for overload relay and fuses

Attention

| | |
|---|--|
|  | <p>The indicated fuse value is the maximum value with regard to the short circuit protection of the starter. The cable size used may specify fuses of a lower value. Fuse specifications IEC: gL/gG Fuse specifications CSA: HRC Form II - UL: Class 5</p> |
|---|--|

Settings

| | | SF 1 | SF 1 | SF 2 | SF 2 |
|-----------|--------------|----------------|--------------|----------------|--------------|
| Frequency | Voltage | Overload relay | Maximum fuse | Overload relay | Maximum fuse |
| IEC | | | | | |
| 50 Hz | 230 V 1~ | 12.6 A | 25 A | 16.4 A | 20 A |
| | 230 V 3~ | -- | -- | 9.7 A | 16 A |
| | 400 V 3~ | -- | -- | 5.6 A | 10 A |
| | 400 V + N 3~ | -- | -- | 5.6 A | 10 A |
| 60 Hz | 380 V 3~ | -- | -- | 5.6 A | 10 A |
| 50/60 Hz | 200 V 3~ | -- | -- | 10.1 A | 16 A |
| UL/CUL | | | | | |
| 60 Hz | 200 V 3~ | -- | | 10.1 A | 15 A* |
| | 230 V 1~ | 10.6 A | 15/15/20 A* | 16.3 A | 20 A* |
| | 230 V 3~ | -- | -- | 9.1 A | 10/15 A* |
| | 460 V 3~ | -- | -- | 4.6 A | 6/8 A* |
| | 575 V 3~ | -- | -- | 3.6 A | 6 A* |

*: Maximum fuses according to HRCII-C, according to Class K5 for units without refrigerant dryer, and according to Class K5 for units with refrigerant dryer, respectively.

| | | SF 4 | SF 4 | SF 6 | SF 6 |
|------------------|----------------|-----------------------|---------------------|-----------------------|---------------------|
| Frequency | Voltage | Overload relay | Maximum fuse | Overload relay | Maximum fuse |
| IEC | | | | | |
| 50 Hz | 200 V 3~ | 17.3 A | 20 A | 25.7 A | 32 A |
| 50 Hz | 230 V 3~ | 15.7 A | 20 A | 23.3 A | 25 A |
| 50 Hz | 400 V 3~ | 9.1 A | 10 A | 13.4 A | 16 A |
| 50 Hz | 400 V + N 3~ | 9.1 A | 10 A | 13.4 A | 16 A |
| 60 Hz | 380 V 3~ | 9.1 A | 10 A | 13.4 A | 16 A |
| UL/CUL | | | | | |
| 60 Hz | 200 V 3~ | 17.3 A | 20 A* | 25.2 A | 30 A* |
| 60 Hz | 208 V | -- | -- | 25 A | 25/30 A* |
| 60 Hz | 230 V 3~ | 15.9 A | 20 A* | 24 A | 25/30 A* |
| 60 Hz | 460 V 3~ | 8 A | 10 A* | 12 A | 15 A* |
| 60 Hz | 575 V 3~ | 6.2 A | 8/10 A* | 9.6 A | 10/15 A* |

*: Maximum fuses according to HRCII-C, according to Class K5 for units without refrigerant dryer, and according to Class K5 for units with refrigerant dryer, respectively.

8.4 Temperature protection and safety valve settings

Temperature shut-down switch settings (TSHH)

| Compressor element outlet temperature | Opens at |
|--|-----------------|
| SF 1 (8 bar / 116 psi) | 70 °C (158 °F) |
| SF 1 (10 bar / 145 psi) | 80° C (176 °F) |
| SF 2 (8 bar and 10 bar / 116 and 145 psi) | 70 °C (158 °F) |
| SF 4 (8 bar and 10 bar / 116 and 145 psi) | 70 °C (158 °F) |
| SF 6 (8 bar and 10 bar / 116 and 145 psi) | 195 °C (383 °F) |

Safety valve (SV)

| Pressure version | Set pressure | Unit |
|-------------------------|---------------------|-------------|
| 8 bar compressors | 8.8 | bar(e) |
| 116 psi compressors | 135 | psi(g) |
| 10 bar compressors | 11 | bar(e) |
| 145 psi compressors | 160 | psi(g) |

8.5 Reference conditions and limitations

Reference conditions

| | | |
|-------------------------------|-----|---|
| Air inlet pressure (absolute) | bar | 1 |
| Air inlet pressure (absolute) | psi | 14.5 |
| Air inlet temperature | °C | 20 |
| Air inlet temperature | °F | 68 |
| Relative humidity | % | 0 |
| Working pressure | | See section Compressor data . |

Limits

| | | |
|-------------------------------|----|---|
| Maximum working pressure | | See section Compressor data . |
| Maximum air inlet temperature | °C | 40 |
| Maximum air inlet temperature | °F | 104 |
| Minimum ambient temperature | °C | 0 |
| Minimum ambient temperature | °F | 32 |

8.6 Compressor data



All data specified below apply under reference conditions, see section [Reference conditions and limitations](#).

| Compressor type | | SF 1 | SF 1 | SF 2 | SF 2 |
|--|--------|------------------|-------------------|------------------|-------------------|
| | | 8 bar 116 psi | 10 bar 145 psi | 8 bar 116 psi | 10 bar 145 psi |
| Maximum working pressure (Pack) | bar(e) | 8 | 10 | 8 | 10 |
| Maximum working pressure (Pack) | psi(g) | 116 | 145 | 116 | 145 |
| Maximum working pressure (Full-Feature) | bar(e) | 7.75 | 9.75 | 7.75 | 9.75 |
| Maximum working pressure (Full-Feature) | psi(g) | 112 | 141 | 112 | 141 |
| Reference working pressure | bar(e) | 7 | 10 | 7 | 10 |
| Reference working pressure | psi(g) | 100 | 145 | 100 | 145 |
| Air temperature at outlet valve (SF Pack), approx. | °C | 25 | 25 | 25 | 25 |
| Air temperature at outlet valve (SF Pack), approx. | °F | 77 | 77 | 77 | 77 |
| Air temperature at outlet valve (SF FF), approx. | °C | 20 | 20 | 20 | 20 |
| Air temperature at outlet valve (SF FF), approx. | °F | 68 | 68 | 68 | 68 |
| Motor shaft speed (50 Hz) | r/min | 1445 | 1445 | 2885 | 2885 |
| Motor shaft speed (60 Hz) | r/min | 1740 | 1740 | 3520 | 3520 |
| Nominal motor power | kW | 1.5 | 1.5 | 2.2 | 2.2 |
| Nominal motor power | hp | 2 | 2 | 3 | 3 |

| Compressor type | | SF 1 | SF 1 | SF 2 | SF 2 |
|---------------------------------|-------|--------------------------|---------------------------|--------------------------|---------------------------|
| | | 8 bar 116 psi | 10 bar 145 psi | 8 bar 116 psi | 10 bar 145 psi |
| Sound pressure level | dB(A) | 52 | 52 | 56 | 56 |
| Refrigerant type (Full-Feature) | | R513a | R513a | R513a | R513a |
| Dew point (refrigerant dryer) | °C | 2 | 2 | 4 | 4 |
| Dew point (refrigerant dryer) | °F | 36 | 36 | 39 | 39 |

| Compressor type | | SF 4 | SF 4 | SF 6 | SF 6 |
|--|--------|--------------------------|---------------------------|--------------------------|---------------------------|
| | | 8 bar 116 psi | 10 bar 145 psi | 8 bar 116 psi | 10 bar 145 psi |
| Maximum working pressure (Pack) | bar(e) | 8 | 10 | 8 | 10 |
| Maximum working pressure (Pack) | psi(g) | 116 | 145 | 116 | 145 |
| Maximum working pressure (Full-Feature) | bar(e) | 7.75 | 9.75 | 7.75 | 9.75 |
| Maximum working pressure (Full-Feature) | psi(g) | 112 | 141 | 112 | 141 |
| Reference working pressure | bar(e) | 7 | 10 | 7 | 10 |
| Reference working pressure | psi(g) | 100 | 145 | 100 | 145 |
| Air temperature at outlet valve (SF Pack), approx. | °C | 32 | 32 | 35 | 35 |
| Air temperature at outlet valve (SF Pack), approx. | °F | 90 | 90 | 95 | 95 |
| Air temperature at outlet valve (SF FF), approx. | °C | 21 | 21 | 22 | 22 |
| Air temperature at outlet valve (SF FF), approx. | °F | 70 | 70 | 72 | 72 |
| Motor shaft speed (50 Hz) | r/min | 2900 | 2900 | 2905 | 2905 |
| Motor shaft speed (60 Hz) | r/min | 3510 | 3510 | 3515 | 3515 |
| Nominal motor power | kW | 3.7 | 3.7 | 5.5 | 5.5 |
| Nominal motor power | hp | 5 | 5 | 7.5 | 7.5 |
| Sound pressure level | dB(A) | 58 | 58 | 59 | 59 |
| Refrigerant type (Full-Feature) | | R513a | R513a | R513a | R513a |
| Dew point (refrigerant dryer) | °C | 3 | 3 | 3 | 3 |
| Dew point (refrigerant dryer) | °F | 37 | 37 | 37 | 37 |

9 Instructions for use

Air receiver

This section applies to compressors including air receiver(s).

| | |
|---|---|
| - | The vessel can contain pressurized air; this can be potentially dangerous if the equipment is misused. |
| - | The vessel shall only be used to store compressed air and shall not be subject to rapid fluctuation of pressure. |
| - | The vessel shall only be used within the pressure and temperature limits stated on the data plate and the testing report, which should be kept in a safe place. |
| - | No alterations must be made to this vessel by welding, drilling or other mechanical methods without the written permission of the manufacturer. |
| - | Make sure that the vessel is equipped with suitable and appropriate safety and control fittings and replace them with new ones if necessary (consult the Parts list). The discharge capacity of the safety valve used must be higher than the capacity of the compressor. |
| - | Do not store the vessel near heating sources and inflammable substances and avoid storing the vessel in badly ventilated rooms. |

| | |
|---|---|
| - | Depending on the conditions of use and the configuration of the equipment, condensate may accumulate inside the tank and must be drained every day to prevent corrosion. This may be done manually, by opening the drain valve, or by means of the automatic drain, if fitted to the vessel. Nevertheless, a weekly check of correct functioning of the automatic valve is needed. This has to be done by opening the manual drain valve and check for condensate. |
| - | Yearly service inspection of the air receiver is needed, as internal corrosion can reduce the steel wall thickness with the consequent risk of bursting. Local rules need to be respected, if applicable. The use of the air receiver is forbidden once the wall thickness reaches the minimum value as indicated in the service manual of the air receiver (part of the documentation delivered with the unit). |
| - | Lifetime of the air receiver mainly depends on the working environment. Avoid installing the compressor in a dirty and corrosive environment, as this can reduce the vessel lifetime dramatically. |
| - | Do not anchor the vessel or attached components directly to the ground or fixed structures. Fit the pressure vessel with vibration dampers to avoid possible fatigue failure caused by vibration of the vessel during use. |
| - | Use the vessel within the pressure and temperature limits stated on the nameplate and the testing report. |
| - | No alterations must be made to this vessel by welding, drilling or other mechanical methods. |

10 Guidelines for inspection

Guidelines

On the Declaration of Conformity / Declaration by the Manufacturer, the harmonised and/or other standards that have been used for the design are shown and/or referred to.

The Declaration of Conformity / Declaration by the Manufacturer is part of the documentation that is supplied with this compressor.

Local legal requirements and/or use outside the limits and/or conditions as specified by the manufacturer may require other inspection periods as mentioned below.

11 Pressure equipment directives

Components subject to Pressure Equipment Directive 97/23/EC (until 20/07/2016) or 2014/68/EU (from 20/07/2016 onwards)

Components subject to 97/23/EC / 2014/68/EU Pressure Equipment Directive greater than or equal to category II

| Pressure version | Part number | Description | PED Class |
|------------------|--------------|--------------|-----------|
| 8 bar | 0830 1008 54 | Safety valve | IV |
| 116 psi | 0830 1008 49 | Safety valve | IV |
| 10 bar | 0830 1007 68 | Safety valve | IV |
| 145 psi | 0830 1008 35 | Safety valve | IV |

Overall rating

The compressors conform to PED smaller than category I.

12 Declaration of conformity

Insert logo here

EU DECLARATION OF CONFORMITY

2 We, (1) declare under our sole responsibility, that the product
 3 Machine name :
 4 Machine type :
 5 Serial number :
 6 Which falls under the provisions of article 12.2 of the EC Directive 2006/42/EC on the approximation of the laws of the Member States relating to machinery, is in conformity with the relevant Essential Health and Safety Requirements of this directive.

The machinery complies also with the requirements of the following directives and their amendments as indicated.

| | Directive on the approximation of laws of the Member States relating to | Harmonized and/or Technical Standards used | Att'mnt |
|---|---|--|---------|
| a | (2) | (3) | |
| b | | | X |
| c | | | |
| d | | | X |
| e | | | |
| f | | | |
| g | | | X |

8a The harmonized and the technical standards used are identified in the attachments hereafter

8b <1> is authorized to compile the technical file.

| | Conformity of the specification to the directives | Conformity of the product to the specification and by implication to the directives |
|----|---|---|
| 11 | Engineering | Manufacturing |
| 12 | Issued by | |
| 13 | Name | |
| 14 | Signature | |
| 15 | Date | |
| 16 | Place | |

84950D

Typical example of a Declaration of Conformity document

(1): Contact address:

Atlas Copco Airpower n.v.
 P.O. Box 100
 B-2610 Wilrijk (Antwerp)
 Belgium

(2): Applicable directives

(3): Standards used

On the Declaration of Conformity / Declaration by the Manufacturer, the harmonized and/or other standards that have been used for the design are shown and/or referred to.

The Declaration of Conformity / Declaration by the Manufacturer is part of the documentation that is supplied with this device.

COMMITTED TO SUSTAINABLE PRODUCTIVITY

We stand by our responsibilities towards our customers, towards the environment and the people around us. We make performance stand the test of time. This is what we call — Sustainable Productivity.

www.atlascopco.com

