



SUPERLIFT
SANITARY LIFTS

STAINLESS MULTITOO

Superlift PharmAssist™ Multi Tool Lift

325lbs Capacity

The **SUPERLIFT Stainless Steel PharmaAssist™ Multi Tool Lift** is fabricated from high-grade 304 and 316 stainless steel for maximum corrosion resistance, even in environments exposed to harsh chemicals and frequent washdowns. Zero hydraulics.

Features

- 325lbs capacity
- Lowered height: 2" with forks
- Raised height: 65"
- Remote hand pendant control
- Electropolished



DUMPER



PLATFORM



FORK



SIDE ROTATOR TILTER



POST



JIB CRANE



BASKET LOADER



ROLL HANDLER

Options

- Dumper
- Platform
- Forks
- Side Rotator Dumper
- Post
- Jib Crane
- Basket Loader
- Roll Handler



SUPERLIFT
SANITARY LIFTS

STAINLESS MULTITOOOL

Superlift PharmAssist™ Multi Tool Lift

325lbs Capacity

Drawings

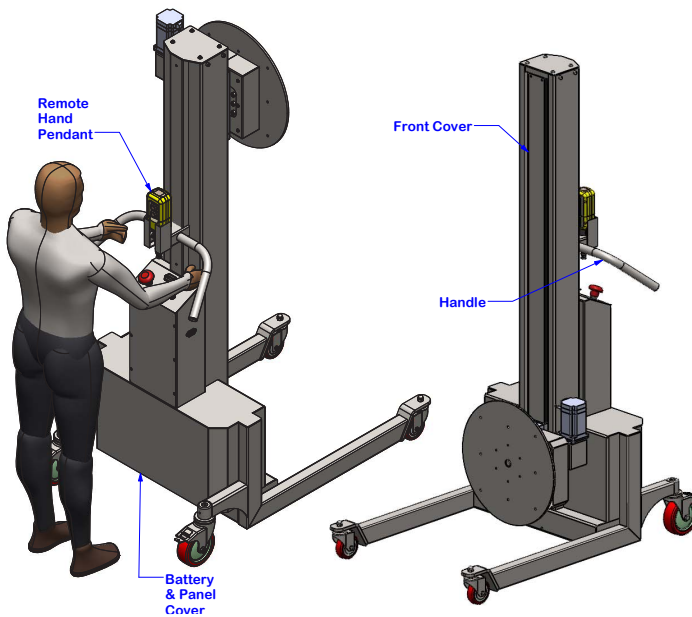

***Other Sizes Available**

