



Please read user's manual before  
operating equipment

Original Instructions

## LABCONCO CORPORATION

8811 Prospect Avenue  
Kansas City, MO 64132  
(800) 821-5525 | +1 (816) 333-8811  
[labconco.com](http://labconco.com)

# Technical Manual

Logic<sup>®</sup> and Cell Logic<sup>®</sup> A2 | B2 Biosafety Cabinets  
PuriCare<sup>®</sup> Procedure Stations



Register this product

## Logic® Type A2 Biosafety Cabinets

30231xxx2	30241xxx2	30251xxx2	30261xxx2	30281xxx2
30238xxx2	30248xxx2	30258xxx2	30268xxx2	30288xxx2
30232xxx2	30242xxx2	30252xxx2	30262xxx2	

## PuriCare® Procedure Stations

31232xxxx2	31242xxx2	31252xxx2	31262xxx2
------------	-----------	-----------	-----------

## Logic® Type B2 Biosafety Cabinets

30348xxx2	30368xxx2
-----------	-----------

## Cell Logic® Type A2 Biosafety Cabinets

32239xxx2	33239xxx2	34239xxx2
32249xxx2	33249xxx2	34249xxx2
32259xxx2	33259xxx2	34259xxx2
32269xxx2	33269xxx2	34269xxx2

## Cell Logic® Type B2 Biosafety Cabinets

32348xxx2	33348xxx2	34348xxx2
32368xxx2	33368xxx2	34368xxx2

Copyright © 2024 Labconco Corporation. The information contained in this manual and the accompanying products are copyrighted and all rights reserved by Labconco Corporation. Labconco Corporation reserves the right to make periodic design changes without obligation to notify any person or entity of such change.

## Warranty

Labconco Corporation provides a warranty to the original buyer for the repair or replacement of parts and reasonable labor as a result of normal and proper use of the equipment with compatible chemicals. Broken glassware and maintenance items, such as filters, gaskets, light bulbs, finishes and lubrication are not warranted. Excluded from warranty are products with improper installation, erratic electrical or utility supply, unauthorized repair, use with incompatible chemicals, or non-factory modifications to the original product.

Logic® Biological Safety Cabinets and PuriCare® Procedure Stations carry a six-year warranty from date of installation or seven years from date of shipment from Labconco, whichever is sooner. Warranty is non-transferable and only applies to the owner (organization) of record.

Buyer is exclusively responsible for the set-up, installation, verification, decontamination or calibration of equipment. This limited warranty covers parts and labor, but not transportation and insurance charges. If the failure is determined to be covered under this warranty, the dealer or Labconco Corporation will authorize repair or replacement of all defective parts to restore the unit to operation. Repairs may be completed by 3<sup>rd</sup> party service agents approved by Labconco Corporation. Labconco Corporation reserves the rights to limit this warranty based on a service agent's travel, working hours, the site's entry restrictions and unobstructed access to serviceable components of the product.

Under no circumstances shall Labconco Corporation be liable for indirect, consequential, or special damages of any kind. This warranty is exclusive and in lieu of all other warranties whether oral, or implied.

## Returned or Damaged Goods

Do not return goods without the prior authorization from Labconco. Unauthorized returns will not be accepted. If your shipment was damaged in transit, you must file a claim directly with the freight carrier. Labconco Corporation and its dealers are not responsible for shipping damages.

The United States Interstate Commerce Commission rules require that claims be filed with the delivery carrier within **fifteen (15) days** of delivery.

## Limitation of Liability

The disposal and/or emission of substances used in connection with this equipment may be governed by various federal, state, or local regulations. All users of this equipment are required to become familiar with any regulations that apply in the user's area concerning the dumping of waste materials in or upon water, land, or air and to comply with such regulations. Labconco Corporation is held harmless with respect to user's compliance with such regulations.

### For additional questions or support:

**Labconco Customer Care** +1 (816) 333-8811

**Labconco Technical Support** (800) 821-5525

**Hours** 7:30 a.m.-5:30 p.m. CST

**Part #3849940 Rev. D  
ECO Q081**

# Table of Contents

---

<b>1: INTRODUCTION</b>	<b>11</b>
Contacting Labconco	11
About This Manual	12
Theory of Operation	12
Type A2	12
Type B2	12
<b>2: SAFETY PRECAUTIONS</b>	<b>13</b>
Typographical Conventions	13
General Safety Precautions	15
Safety Precautions for this Product	17
<b>3: CATALOG NUMBER CONFIGURATOR</b>	<b>19</b>
<b>4: SERIAL TAG</b>	<b>20</b>
Serial Tag Location	20
Serial Tag Information	21
Primary Serial Tag	21
Secondary Serial Tag	21
<b>5: FACTORY TEST REPORT</b>	<b>22</b>
Test Report Location	22
Test Report Information	23
<b>6: ADDITIONAL PRODUCT INFORMATION</b>	<b>24</b>
Data Plate Location	24
Data Plate Information	25

<b>7: EXHAUST SYSTEM CONNECTIONS</b>	<b>26</b>
Exhaust Connection Best Practices	26
Air-Tight Damper	28
Exhaust System Requirements	29
Type A2 Models	29
Cell Logic Type A2 Models	30
Type B2 Models	30
<b>8: CONFIGURATION</b>	<b>31</b>
Accessing Configuration	31
Setting Automatic Operation (Night-Smart™ / Smart-Start™)	32
<b>9: AIRFLOW CALIBRATION</b>	<b>34</b>
Certifier Password	34
Airflow Sensor Zero-Point Calibration	34
Adjusting the Internal Air Damper (A2 Models only)	35
Adjusting Blower Speed	36
(Type B2 Only) Exhaust Airflow Alarm Setpoint	39
Setting the Filter Life Status	40
<b>10: CERTIFICATION</b>	<b>42</b>
Certifier Password	42
Type A2 HEPA Filter Leak Test Preparation	42
Theoretical Upstream Concentration	43
Upstream Concentration Sampling	43
Type A2 Supply HEPA Filter Leak Test	44
Acceptance Criteria	46
Type A2 Exhaust HEPA Filter Leak Test	47
Acceptance Criteria	48
Type B2 Supply HEPA Filter Leak Test Preparation	49
Theoretical Upstream Concentration	49

Upstream Concentration Sampling	49
<b>Type B2 Supply HEPA Filter Leak Test</b>	<b>51</b>
Acceptance Criteria	52
<b>Type B2 Exhaust HEPA Filter Leak Test Preparation</b>	<b>53</b>
Theoretical Upstream Concentration	53
<b>Type B2 Exhaust HEPA Filter Leak Test</b>	<b>54</b>
Acceptance Criteria	54
<b>Downflow Velocity</b>	<b>55</b>
Acceptance Criteria	56
<b>Inflow Velocity</b>	<b>57</b>
Primary Method	57
Acceptance Criteria	59
Secondary Method	60
Acceptance Criteria	64
<b>Work Area Air Cleanliness Test (optional)</b>	<b>65</b>
Acceptance Criteria	65
<b>Lighting Test (optional)</b>	<b>66</b>
Acceptance Criteria	66
<b>Noise Test (optional)</b>	<b>67</b>
Acceptance Criteria	67
<b>Vibration Test (optional)</b>	<b>67</b>
Acceptance Criteria	67
<b>UV Light Intensity Test (optional)</b>	<b>68</b>
Acceptance Criteria	68
<b>Ground Fault Circuit Interrupter (GFCI) Test</b>	<b>69</b>
Acceptance Criteria	69

## **11: QUICKCHARTS** **70**

<b>QuickChart – Type A2 3-ft &amp; 4-ft</b>	<b>71</b>
<b>QuickChart – Type A2 5-ft &amp; 6-ft</b>	<b>72</b>
<b>QuickChart – Type A2 8-ft</b>	<b>73</b>
Type A2 Footnotes	74
<b>QuickChart – Type B2</b>	<b>75</b>
Type B2 Footnotes	76

## **12: ADVANCED SERVICE PROCEDURES** **77**

<b>Tools</b>	<b>77</b>
Required	77
Optional	77
<b>Removal of External Dress Panels</b>	<b>78</b>
Dress Panel	78
Side Panels	79
Exhaust Cover (A2 Only)	80
<b>Front Sash</b>	<b>81</b>
Sash Level Adjustment	81
Sash Sensor Adjustment or Replacement	82
<b>HEPA Filter Replacement</b>	<b>84</b>
Type A2	84
Type B2	87
<b>Blower/Motor Replacement</b>	<b>90</b>
Type A2 & B2	90
<b>Changing the LED Lamps</b>	<b>93</b>
<b>LED Lamp Socket Cap Replacement</b>	<b>96</b>
<b>Changing the Optional UV Lamp</b>	<b>97</b>
<b>UV Lamp Socket Replacement</b>	<b>98</b>
<b>Type B2 Prefilter Replacement</b>	<b>99</b>
<b>Air-Tight Damper Adjustment</b>	<b>99</b>
<b>Preparing the Biosafety Cabinet for Gaseous Sterilization</b>	<b>101</b>
<b>Service Fixture Installation &amp; Service Connection</b>	<b>102</b>

## **13: ELECTRICAL COMPONENTS** **105**

<b>Electronics Module</b>	<b>105</b>
Electronic Module Components	106
Resetting a Circuit Breaker	107
Power Supply	108
<b>Display Board</b>	<b>109</b>
<b>Speaker</b>	<b>110</b>
<b>Blower Motor</b>	<b>111</b>

<b>Wiring Diagrams</b>	<b>113</b>
100-115V – 3-ft, 4-ft, 5-ft, & 6-ft	113
208-240V – 3-ft, 4-ft, 5-ft, & 6-ft	114
100-115V – 8-ft	115
208-240V – 8-ft	116

## **14: TROUBLESHOOTING** **117**

<b>Blower and Lights not working</b>	<b>117</b>
<b>Blower only will not start</b>	<b>118</b>
<b>Lights only will not illuminate</b>	<b>119</b>
<b>UV Light will not illuminate</b>	<b>120</b>
<b>Airflow Alert activating</b>	<b>121</b>
<b>Filter Life Status not at 100% when new</b>	<b>122</b>
<b>Contamination in the work area</b>	<b>123</b>
<b>(B2 Only) Exhaust Alarm activates 60 seconds after turning blower ON</b>	<b>124</b>
<b>Advanced Troubleshooting</b>	<b>125</b>
Download a Data Log	126
Download a Diagnostics File	127
Download an Event History File	128
Download a Logcat File	129
Email Files to Product Service	130

## **15: DIAGNOSTICS** **131**

<b>Blower</b>	<b>132</b>
<b>Light</b>	<b>132</b>
<b>Outlet</b>	<b>132</b>
<b>UV Light</b>	<b>132</b>
<b>Sash Sensors</b>	<b>133</b>
<b>Canopy (Optional)</b>	<b>134</b>
<b>Gas Valve (Optional)</b>	<b>134</b>
<b>Keypad</b>	<b>134</b>

<b>16: REMOTE COMMUNICATION KIT</b>	<b>136</b>
<b>Installation</b>	<b>136</b>
Example 1 – Blower Relay Contact (Single Phase AC)	140
Example 2 – Blower Relay Contact (Three Phase AC)	141
<b>BMS Data Output</b>	<b>142</b>
Connection Type	142
Data Output Format	143
Data Output Rate	143
Data Output String Definition	144
Data Output Software Requirements	144
<b>17: VENTUS II CANOPY CONNECTION KIT</b>	<b>145</b>
<b>Kit Catalog Numbers</b>	<b>146</b>
<b>Installation Procedure</b>	<b>146</b>
<b>Exhaust Damper Installation Procedure</b>	<b>148</b>
<b>Canopy Switch Wiring Connection</b>	<b>148</b>
<b>Calibrate for Operation</b>	<b>150</b>
<b>18: AIRFLOW SENSOR KIT</b>	<b>151</b>
<b>Installation – Type A2 without Ventus II canopy</b>	<b>151</b>
<b>Installation – Type A2 with Ventus II canopy</b>	<b>153</b>
<b>Connection to Electronics Module</b>	<b>155</b>
<b>Configuration (new install only)</b>	<b>156</b>
<b>Calibration</b>	<b>157</b>
<b>19: UV LAMP KIT</b>	<b>161</b>
<b>Kit Catalog Numbers</b>	<b>161</b>
<b>Installation</b>	<b>161</b>
<b>Configuration</b>	<b>164</b>
<b>20: IV BAR KIT</b>	<b>165</b>

Kit Catalog Numbers	165
Installation	165
<b>21: PREFILTER KIT</b>	<b>167</b>
Kit Catalog Numbers (Type A2 and B2 only)	167
Installation	167
<b>22: PARTS LIST</b>	<b>169</b>
Type A2 Consumables	169
Type B2 Consumables	171
Advanced Service Components	172

# 1: Introduction

---

This text is designed for biosafety cabinet certifiers and servicers. Labconco has compiled this information to use in the certification or servicing of our Logic, Cell Logic biosafety cabinets, and Puricare procedure stations.

As always, we at Labconco want to assist you in a better understanding of our products and their operation; if you have any questions, or need additional information, please contact us.

Thank you for all your support in the past, and in the future.

## Contacting Labconco

LABCONCO Corporation  
8811 Prospect Avenue  
Kansas City, MO 64132  
USA

Our hours of operation are from 7:30 am - 5:30 pm CST, Monday through Friday, except national holidays.

We can be reached at the following numbers:  
1 (800) 821-5525    +1 (816) 333-8811

Should you require technical assistance, service parts, or have general questions regarding the product, please direct them to our Product Service Department, so that your call can be properly routed and answered.

## About This Manual

This manual contains technical information for all types and models of Labconco biosafety cabinets and procedure stations.

## Theory of Operation

This section offers a brief overview of the operation of Type A2 and B2 biosafety cabinets.

### Type A2

All Logic Type A2 biosafety cabinets meet the airflow requirements of ANSI/NSF Standard 49.

Approximately 55-60% of the air in the cabinet is filtered and recirculated, while 40-45% is filtered and exhausted. All Type A2 Logic biosafety cabinets feature intrinsically safe designs, jacketing contaminated positive pressure areas with negative pressure zones.



Figure 1-1

### Type B2

All Logic Type B2 biosafety cabinets meet the airflow requirements of ANSI/NSF Standard 49. All of the air in the cabinet is filtered and none is recirculated. All Type B2 Logic biosafety cabinets feature intrinsically safe designs, with all contaminated areas under negative pressure.



Figure 1-2

## 2: Safety Precautions

---

Before unpacking, installing, operating, maintaining, or servicing this equipment, read the following safety warnings and precautions.

Avant le déballage, l'installation, le fonctionnement, l'entretien ou la maintenance de cet équipement, lire les avertissements de sécurité et les précautions d'emploi.



**CAUTION** – See Manual. When this symbol is on the equipment, it indicates a caution that is detailed in this manual.

**MISE EN GARDE** – Voir le manuel. Lorsque ce symbole est apposé sur l'équipement, il renvoie à une mise en garde détaillée dans ce manuel.

### Typographical Conventions



**DANGER** – An imminently hazardous situation which, if not avoided, will result in death or serious injury.

**DANGER** – Situation dangereuse imminente qui, si elle n'est pas évitée, peut entraîner la mort ou des blessures graves.



**CAUTION** – Indicates a potentially hazardous situation which, if not avoided, may result in minor or moderate injury or damage to property.

**MISE EN GARDE** – Signale une situation potentiellement dangereuse qui, si elle n'est pas évitée, peut provoquer des blessures mineures à modérées ou des dommages matériels.



**NOTE** – Advice or suggestions to help the process.

**REMARQUE** – Conseils ou suggestions pour le déroulement du processus.



**BURN RISK (HIGH TEMPERATURE)** – Air or components that will be very hot. Take care not to touch these defined areas. Failure to avoid these areas may result in moderate to severe injury.

**RISQUE DE BRÛLURE (TEMPÉRATURE ÉLEVÉE)** – Air ambiant ou composant devenant très chaud. Veiller à ne pas toucher ces zones délimitées. L'absence de précaution pour éviter ces zones peut entraîner des blessures modérées, voire graves.



**EXTREME COLD (LOW TEMPERATURE)** – Air or components that will be very COLD. Take care not to touch these defined areas. Failure to avoid these areas may result in moderate to severe injury.

**FROID INTENSE (TEMPÉRATURE BASSE)** – Air ambiant ou composant devenant très froid. Veiller à ne pas toucher ces zones délimitées. L'absence de précaution pour éviter ces zones peut entraîner des blessures modérées voire graves.



**PINCH POINT** – Areas or components that can pinch or cut. Take care not to touch these defined areas.

**POINT DE PINCEMENT** – Zones ou composants présentant un risque de pincement ou de coupure. Veiller à ne pas toucher ces zones délimitées.



**MOVING PARTS** – Areas or components that contain moving parts. Take care not to touch these defined areas.

**PIÈCES MOBILES** – Zones ou composants contenant des pièces mobiles. Veiller à ne pas toucher ces zones délimitées.



**RISK OF ELECTRICAL SHOCK** – The specified procedure or area poses a risk of electrical shock. ALWAYS disconnect main power cord or electrical supply before proceeding.

**RISQUE DE CHOC ÉLECTRIQUE** – La procédure ou la zone spécifiée présente un risque de choc électrique. TOUJOURS débrancher le cordon d'alimentation secteur ou l'alimentation électrique avant toute intervention.



**FLAMMABLE / NO SOLVENTS** – Do not place flammable liquids or solvents in this product.

**INFLAMMABLE / PAS DE SOLVANTS** – Ne placez aucun liquid inflammable dans cette produit.



**LIFTING HAZARD** – Do not lift or move this equipment without assistance.  
**DANGER DE LEVAGE** – Ne pas soulever ou déplacer cet équipement sans assistance.



**MAGNETIC FIELD IN USE** – Magnets or magnetic field present.  
**CHAMP MAGNETIQUE UTILISE** – Présence d'aimants ou de champ magnétique.



**DO NOT TOUCH** – Components or areas indicated are sensitive and will suffer damage if touched. Take care not to touch these defined components or areas. Failure to avoid these areas will result in damage to the product.  
**NE PAS TOUCHER** – Les composants ou les zones indiquées sont sensibles et subiront des dégâts s'ils sont touchés. Veiller à ne pas toucher ces composants ou zones délimité(e)s. L'absence de précaution pour éviter ces zones endommagera le produit.



**TOOL REQUIRED** – Tool required to access specified area.  
**OUTIL NÉCESSAIRE** – Outil nécessaire pour accéder à la zone spécifiée.

## General Safety Precautions

Follow all the safety precautions described in this section.



Before removing any panels which require a tool for removal, **ALWAYS** disconnect the main power cord or electrical supply. Failure to remove all electrical power before proceeding will result in moderate to serious injury, death, or damage to property.

Avant le retrait d'un panneau nécessitant l'utilisation d'un outil, **TOUJOURS** débrancher le cordon d'alimentation secteur ou l'alimentation électrique. Le non-respect de la consigne consistant à couper complètement l'alimentation électrique avant toute intervention peut entraîner des blessures graves, la mort ou des dommages matériels.



Never contact moving parts with your person. Failure to avoid moving parts will result in moderate to serious injury, death, or damage to property.

Ne jamais toucher les parties mobiles. Le non-respect de la consigne consistant à éviter les pièces mobiles peut entraîner des blessures graves, la mort ou des dommages matériels.



Never misuse this product. Never disable, override, or otherwise bypass safety guards, panels, switches, sensors or alarms. Doing so will result in moderate to serious injury, death, or damage to this product or property.

Ne jamais utiliser ce produit à mauvais escient. Ne jamais désactiver, annuler ou contourner les capots, panneaux, interrupteurs, capteurs ou alarmes de sécurité. Ceci entraînerait des blessures graves, la mort ou des dommages matériels à ce produit ou à d'autres biens.



If the unit is not operated as specified in this manual it may impair the protection provided by the unit.

Si l'unité n'est pas utilisée comme spécifié dans ce manuel il peut diminuer la protection fournie par l'unité.



Do not position the unit so that it is difficult to operate the main disconnect device.

Ne placez pas l'appareil de sorte qu'il est difficile de faire fonctionner le dispositif principal de déconnexion.



Do not lift or move this equipment without assistance.

Ne pas soulever ou déplacer cet équipement sans assistance.

## Safety Precautions for this Product



Electrical outlets in the cabinet are restricted to 5 amps (100-115v) or 3 amps (230v) maximum current.  
Prises électriques dans l'armoire sont limitées à 5 (100-115v) o 3 (230v) courant maximum ampères.



Do not use any detachable power cord that is not adequately rated for the unit.  
Ne pas utiliser un fil électrique amovible qui n'est pas du tension nominale de l'appareil.

The biosafety cabinet should be certified by a certification technician before its initial use. The cabinet should be recertified whenever it is relocated, serviced or at least annually thereafter. Filter integrity and airflow performance should be verified before using the cabinet.



Some internal components of the biosafety cabinet may become contaminated during operation of the unit. Only experienced personnel competent in decontamination procedures should decontaminate the cabinet before servicing these components. If you have any questions regarding certification agencies, or need assistance in locating one, contact Labconco's Product Service Department at 800-821-5525 or 816-333-8811.

DO NOT load more than 150 lbs. (68 kg) in the work area. Exceeding this limit may damage the work surface and its supports. Excessive weight in the cabinet may increase the risk of it overturning, or failure of hydraulic lift stands, resulting in the cabinet and stand overturning. If your application requires loading more than 150 lbs. (68 kg), contact Labconco's Product Service Department at 800-821-5525 or 816-333-8811 for assistance.



Avoid the use of flammable gases or solvents in the biosafety cabinet. Care must be taken to ensure against the concentration of flammable or explosive gases or vapors. An open flame should NOT be used in the biosafety cabinet. Open flames will disrupt airflow patterns, burn the HEPA filter and/or damage the filter's adhesive. Gases under high pressure should not be used in the biosafety cabinet, as they may disrupt its airflow patterns.

HEPA filters only remove particulate matter. Operations generating volatile toxic chemicals or radionuclides must be evaluated carefully.



The media of HEPA filters is fragile and should not be touched. Avoid puncturing either HEPA filter during installation or normal operation. If you suspect that a HEPA filter has been damaged, DO NOT use the cabinet; contact a local certification agency or Labconco at 800-821-5525 or 816-333-8811 for re-certification information.

The HEPA filters in the biosafety cabinet will gradually accumulate airborne particulate matter from the room and from work performed in the cabinet. The rate of accumulation will depend upon the cleanliness of the room air, operating time and the nature of work being done in the cabinet. The Filter Gauge accurately displays the amount of filter life remaining.

Proper operation of the cabinet depends largely upon its location and the operator's work habits.

Avoid direct exposure of plastic or coated materials to ultraviolet (UV) radiation. Never bypass the UV safety interlock that only allows the UV light to work when the sash is closed. When surface disinfecting the biosafety cabinet:

- Avoid splashing the disinfecting solution on skin or clothing.
- Ensure adequate ventilation.
- Carefully follow the disinfectant's safety instructions.
- Always dispose of disinfecting solutions in accordance with local and national laws.
- DO NOT allow disinfectants with high concentrations of free chlorine to contact the stainless steel components of the biosafety cabinet for a long period of time. Free chlorine will corrode stainless steel after extended contact.



Biosafety cabinets should be decontaminated for any of the following reasons:

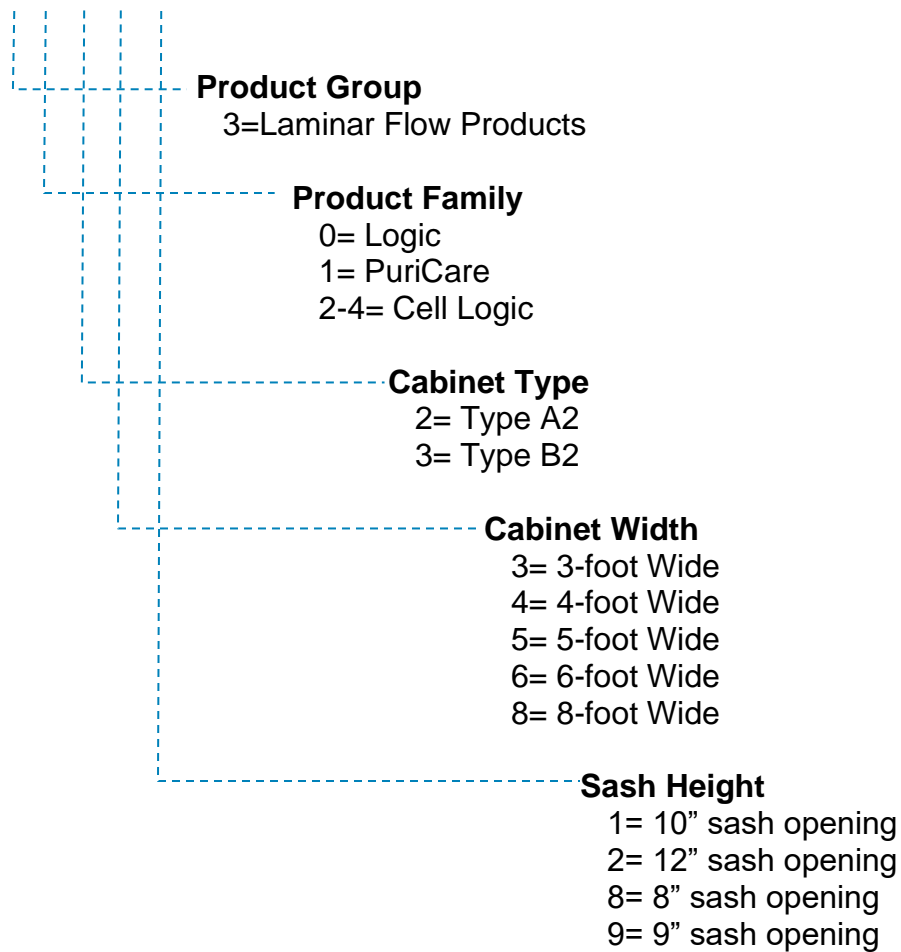
- Before maintenance work requiring entry into contaminated areas.
- Before HEPA filter changes.
- Before performing certification tests requiring entry into contaminated areas.
- Before relocating the cabinet.
- Before changing research programs.
- After the gross spill of biohazardous material or toxic chemicals.

## 3: Catalog Number Configurator

---

Logic and Axiom biosafety cabinets and Puricare procedure stations utilize catalog numbers (also referred to as model numbers) where each digit of the catalog number provides key information about the model. Use the configurator below to identify specifics about your product.

3 0 2 4 8 x x x 2



## 4: Serial Tag

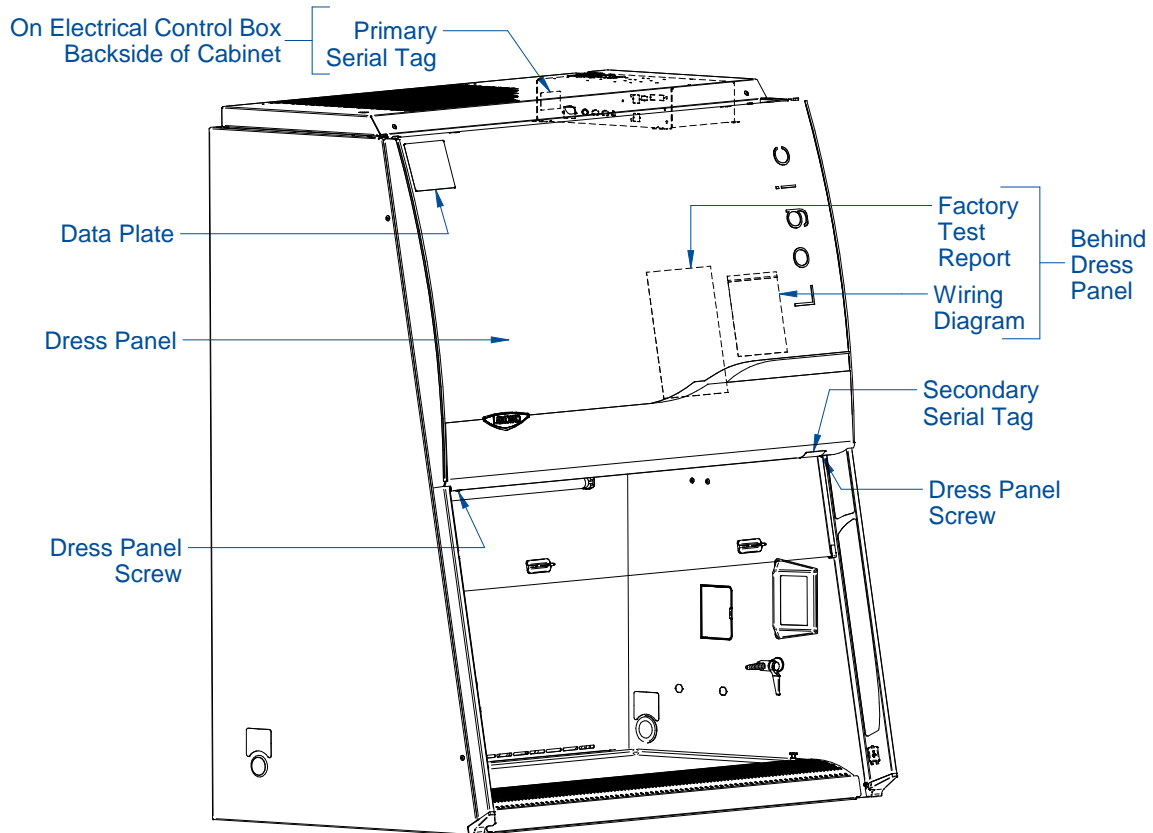
---

If you need to contact Labconco regarding this product, it is required you provide the serial number. The serial number provides all product details, including the revision level under which the product was constructed. It is the single, most important piece of information when assistance is requested.

### Serial Tag Location

See Figure 4-1 for the location of the primary and secondary serial tags.

**Figure 4-1**



## Serial Tag Information

The following information is located on the Serial Tags:

### Primary Serial Tag

- Serial Number
- Catalog (Model) Number
- Revision
- Electrical Requirements
  - Voltage
  - Frequency
  - Amperage
  - Phase

**Figure 4-2**

Made in U.S.A.			
<b>LABCONCO CORPORATION</b>			
8811 PROSPECT AVE., KANSAS CITY, MO 64132			
CATALOG NO.	SERIAL NO.	REV.	
<input type="text"/>			
VOLTS AC	PHASE	CYCLE	AMP. $\Delta$
<input type="text"/>			

### Secondary Serial Tag

- Serial Number
- Catalog (Model) Number

**Figure 4-3**

<b>LABCONCO</b>	
(800) 821-5525 • (816) 333-8811	
CAT.	<input type="text"/>
S/N	<input type="text"/>

## 5: Factory Test Report

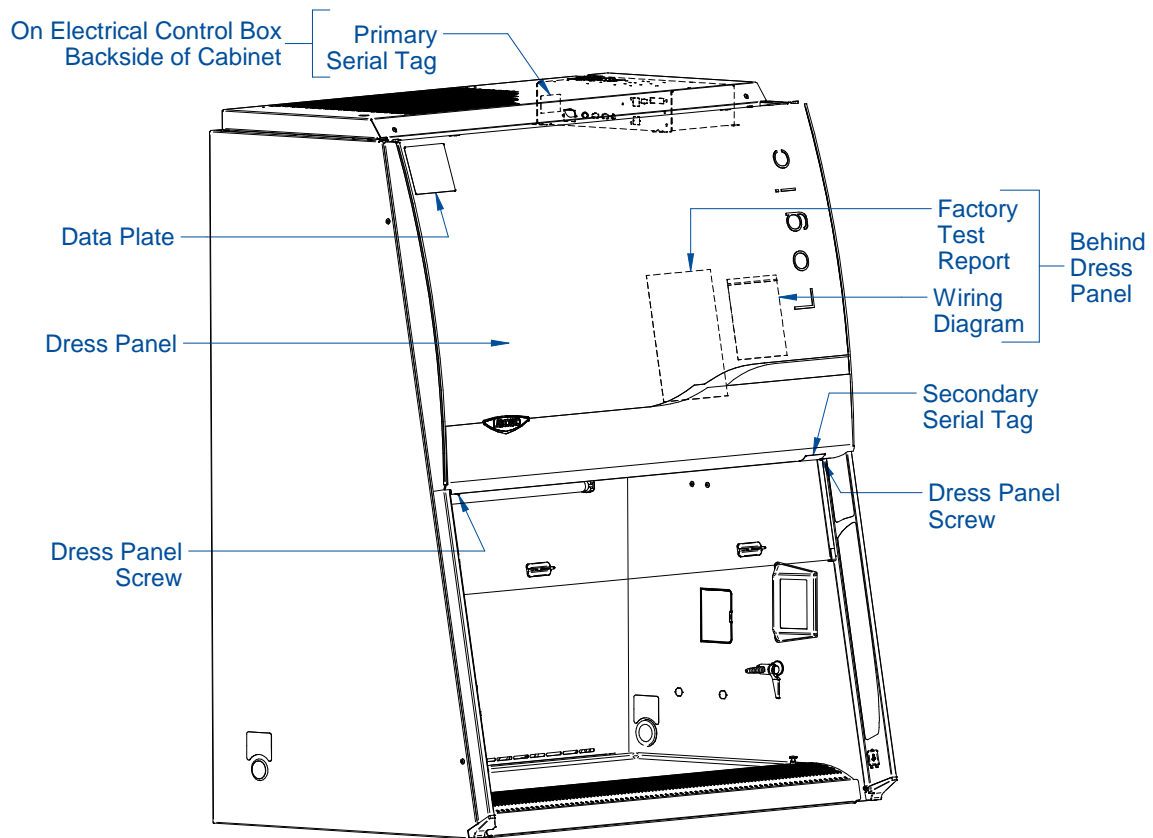
---

The factory test report is a valuable reference for the product's airflows and blower setting(s), as well as information about the HEPA filters, and accessories that may be factory installed.

### Test Report Location

The test report is located on the blower/plenum cover, which is behind the front Dress Panel. See Figure 5-1. The Dress Panel Screws must be removed, and the Dress Panel lifted off to reach the test report.

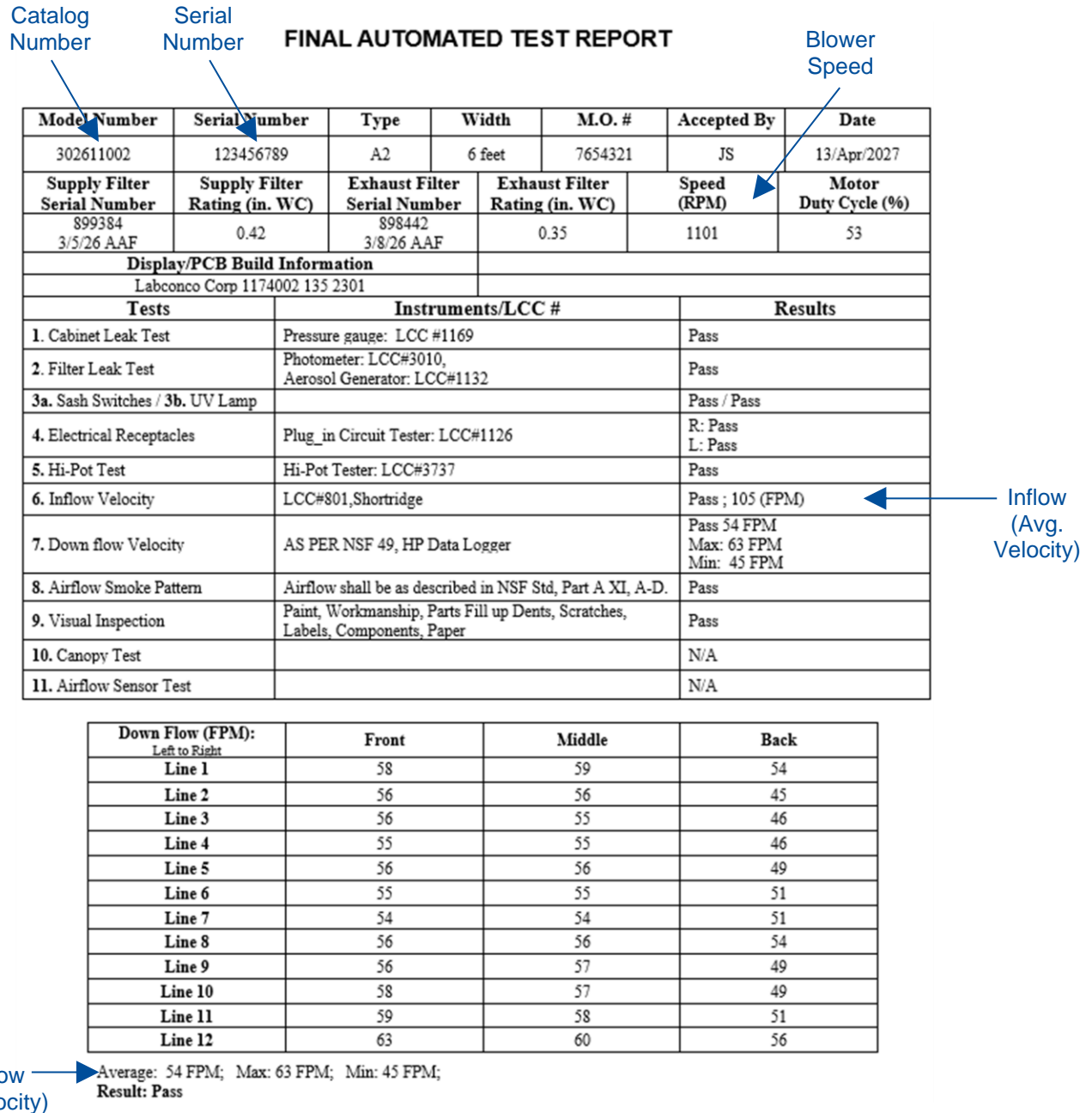
**Figure 5-1**



## Test Report Information

See Figure 5-2 for a typical test report. Review this carefully to identify where on the report specific information is located. Important information is highlighted below.

**Figure 5-2**



**Note:** The test report shown is an A2-10inch model with one internal blower.

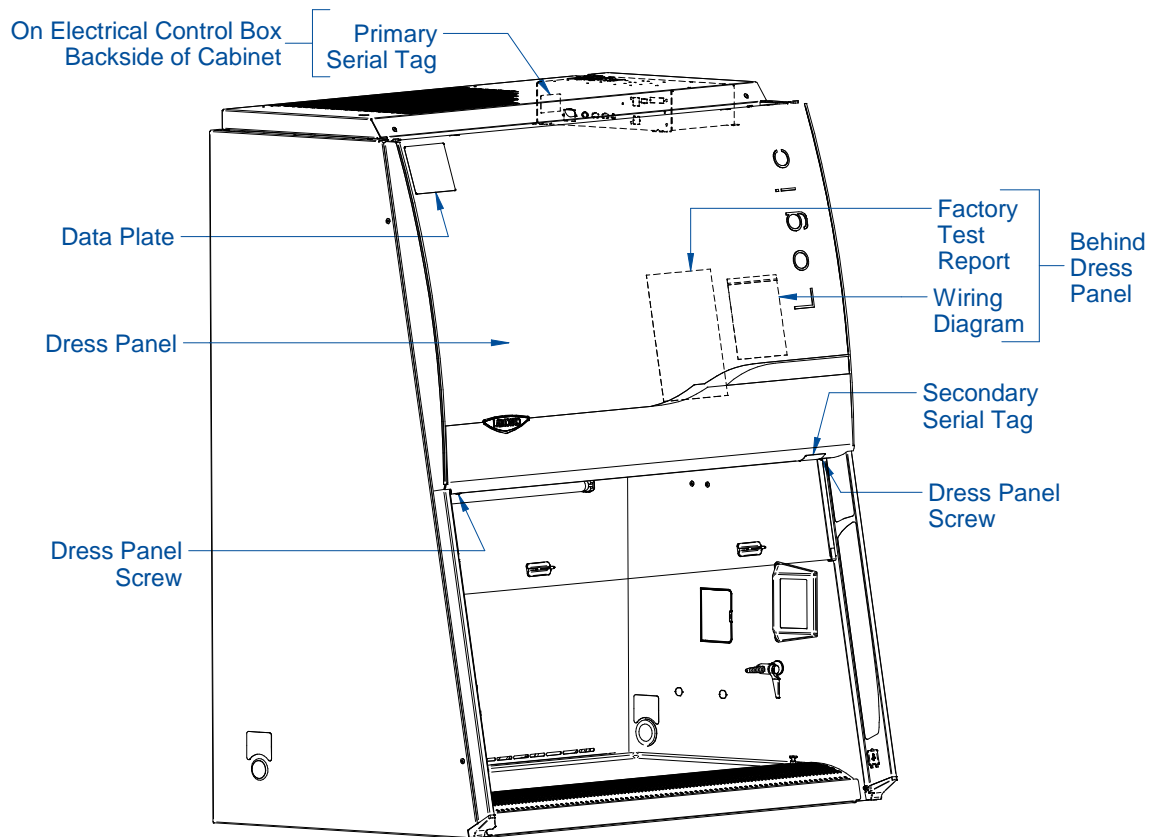
## 6: Additional Product Information

All NSF-Listed biosafety cabinets are required by NSF49 regulations to display a Data Plate on the front of the product in a readily visible location.

### Data Plate Location

See Figure 6-1 for the Data Plate location.

Figure 6-1





## 7: Exhaust System Connections

---

Not all models of biosafety cabinets are connected to a remote or building exhaust system. Type A2 models may recirculate their exhaust back to the laboratory, or remove their exhaust air from the lab via a Ventus II™ Canopy (also referred to as a Thimble Connection) connected to a remote (building) exhaust system. Type B2 models must always be connected to an exhaust system.

This section provides recommended best practices when connecting a biosafety cabinet to a remote exhaust system to avoid operational problems with the cabinet. In addition, the specific exhaust volumes and vacuum pressures required to properly operate each cabinet model are listed by cabinet width and sash operating height.



If a biosafety cabinet is being altered from recirculating operation to ducted (exhausted) operation in the field, it must be recertified by a qualified certifier before being used.

### Exhaust Connection Best Practices



**Note:** Only connect the biosafety cabinet to a suitable exhaust system that is dedicated to the biosafety cabinet, or dedicated to exhausting laboratory ventilation equipment. Do NOT connect the biosafety cabinet to the building's general HVAC system for room exhaust.

Examine the location to ensure that it accommodates the cabinet's exhaust duct. The area directly above the cabinet's exhaust port should be clear of structural elements, water and utility lines, or other fixed obstructions. There should be enough clearance to accommodate a 10-inch diameter duct. See Figure 7-1.

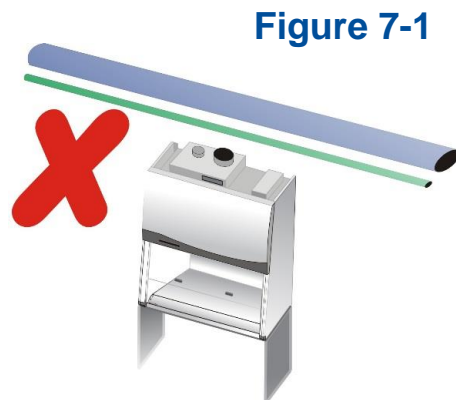
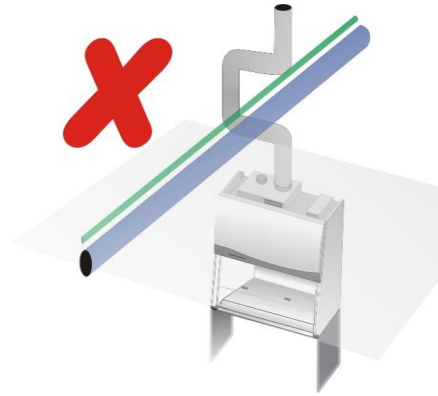


Figure 7-1

**Figure 7-2**

Avoid cabinet locations that require an elbow directly above the cabinet's exhaust connection or an excessive number of elbows in the exhaust system. There should be a straight length 10 duct diameters long between the cabinet connection and any elbow, and between subsequent elbows. See Figure 7-2.



This information applies to Canopy-Exhausted Type A2 only

**Figure 7-3**

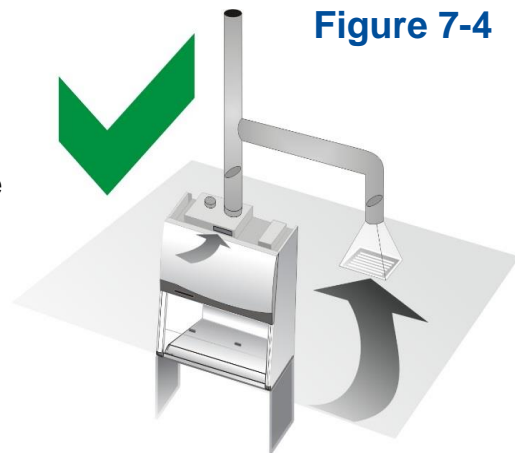
The Inlet Relief Valve located on the top of the cabinet is designed to draw a maximum of 300 CFM (170 m<sup>3</sup>/hr).

Attempting to draw additional room air through the valve (room air exhaust), can result in unstable cabinet operation. See Figure 7-3.



**Figure 7-4**

If additional room exhaust needs to be drawn through the exhaust system and/or the exhaust volume air through the biosafety cabinet must be maintained when the biosafety cabinet is off to maintain room pressurization or air change requirements, install an additional duct and balancing damper downstream of the cabinet's damper. This will allow for proper balancing of the system. See Figure 7-4.

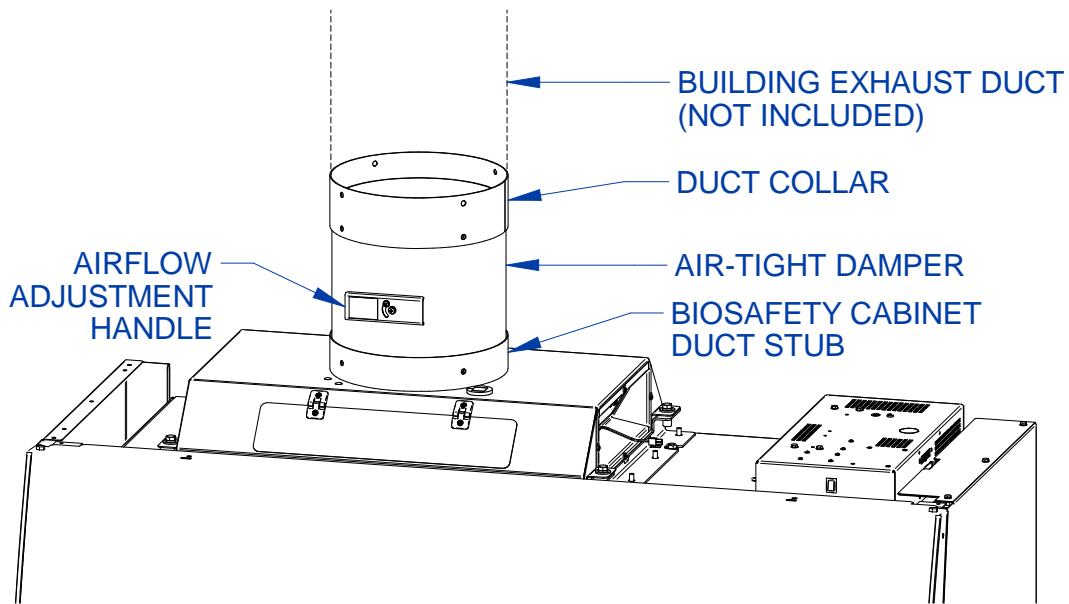




## Air-Tight Damper

On canopy-exhausted Type A2 models, Labconco highly recommends installing an air-tight damper above each biosafety cabinet when connected to a building exhaust system. The air-tight damper allows for fine adjustment of the exhaust air volume provided, in order to correctly set the necessary exhaust airflow for each biosafety cabinet. It also allows the biosafety cabinet to be sealed off from the building exhaust system, should it become necessary to do so.

**Figure 7-5**



Visual appearance of biosafety cabinet and exhaust connection may vary by model.



**Note:** Type B2 models must always be connected to a remote exhaust system. Type B2 models have an air-tight damper built into the biosafety cabinet's exhaust housing.

## Exhaust System Requirements

The exhaust system must be capable of moving the following volumes of exhaust air at the negative pressures listed. The **Airflow Volumes** are the values recorded via direct measurement using a flow hood on the exhaust duct above the cabinet. The **Concurrent Balance Values** are measured in the exhaust duct via traverse methodology, and will always be higher due to differences in volume measurement methodologies.

For Type A2 models with Ventus II Canopy Connections, see Table 7-1. For Ventus II Canopy Connection Type A2 models with Night-Smart enabled, see Table 7-2.

For Cell Logic Type A2 models with Ventus II Canopy Connections, see Table 7-3.

For Type B2 models, see Table 7-4.

### Type A2 Models

**Table 7-1**

Logic Type A2 Model	Airflow Volume		Concurrent Balance Value		Recommended Duct Vacuum <sup>1</sup>	
	ft <sup>3</sup> /min	m <sup>3</sup> /hr	ft <sup>3</sup> /min	m <sup>3</sup> /hr	WC <sup>2</sup>	Pa
3-foot, 8" Sash	250	425	275	467	0.03	7
3-foot, 10" Sash	290	493	319	542	0.04	10
3-foot, 12" Sash	345	586	380	645	0.04	10
4-foot, 8" Sash	350	595	385	654	0.09	22
4-foot, 10" Sash	420	714	462	785	0.12	30
4-foot, 12" Sash	490	833	539	916	0.15	37
5-foot, 8" Sash	430	731	473	804	0.13	32
5-foot, 10" Sash	525	892	578	981	0.18	45
5-foot, 12" Sash	640	1087	704	1196	0.24	60
6-foot, 8" Sash	570	968	627	1065	0.20	49
6-foot, 10" Sash	700	1189	770	1308	0.27	66
6-foot, 12" Sash	830	1410	913	1551	0.38	95
8-foot, 8" Sash <sup>3</sup>	345	586	380	645	0.08	19
8-foot, 10" Sash <sup>3</sup>	430	731	473	804	0.11	27

1: Unlike Type B biosafety cabinets, the recommended vacuum will remain constant throughout the life of the exhaust HEPA filter. The Duct Vacuum reading was taken in the center of the duct diameter, halfway up the BSC Duct Stub (reference Figure 7-5). Duct vacuums above 0.5 inches H<sub>2</sub>O (125 Pa) may result in erratic operation and throw an alarm condition from the product.

2: WC = Inches of Water Column, typically expressed in units of *inches H<sub>2</sub>O*.

3: 8-foot A2 BSCs require two canopy connections. The data listed in Table 7-1 is for each canopy, not the sum of both.

If Night-Smart is enabled, the exhaust system can be lowered to the approximate volumes listed in Table 7-2 when the sash is closed.

**Table 7-2**

Logic Type A2 Model	Approximate Airflow Volume		Recommended Duct Vacuum	
	ft <sup>3</sup> /min	m <sup>3</sup> /hr	WC	Pa
3-foot	75	127	0.02	5
4-foot	180	306	0.02	5
5-foot	200	340	0.06	16
6-foot	320	544	0.10	24
8-foot (Per Canopy)	135	229	0.02	5

Cell Logic Type A2 Models

**Table 7-3**

Logic Type A2 Model	Airflow Volume		Concurrent Balance Value		Recommended Duct Vacuum <sup>1</sup>	
	ft <sup>3</sup> /min	m <sup>3</sup> /hr	ft <sup>3</sup> /min	m <sup>3</sup> /hr	WC <sup>2</sup>	Pa
3-foot, 9" Sash	270	459	297	505	0.04	10
4-foot, 9" Sash	385	654	424	720	0.11	26
5-foot, 9" Sash	478	811	525	892	0.16	39
6-foot, 9" Sash	635	1079	699	1187	0.23	57

1: Unlike Type B biosafety cabinets, the recommended vacuum will remain constant throughout the life of the exhaust HEPA filter. Duct vacuums above 0.5 inches H<sub>2</sub>O (125 Pa) may result in erratic operation and throw an alarm condition from the product.

2: WC = Inches of Water Column, typically expressed in units of *inches H<sub>2</sub>O*.

Type B2 Models

**Table 7-4**

Logic Type B2 Model	Airflow Volume		Concurrent Balance Value		Recommended Duct Vacuum	
	ft <sup>3</sup> /min	m <sup>3</sup> /hr	ft <sup>3</sup> /min	m <sup>3</sup> /hr	WC <sup>1</sup>	Pa
4-foot, 8" Sash	695	1181	818	1390	1.8	448
6-foot, 8" Sash	1175	1996	1382	2348	2.5	622

1: WC = Inches of Water Column, typically expressed in units of *inches H<sub>2</sub>O*.

## 8: Configuration

This section provides instructions to access and understand the current configuration of the biosafety cabinet and make changes to the configuration. It is important to understand the current configuration of the biosafety cabinet for many reasons, some of which include verifying model type, verifying accessories installed, and troubleshooting.

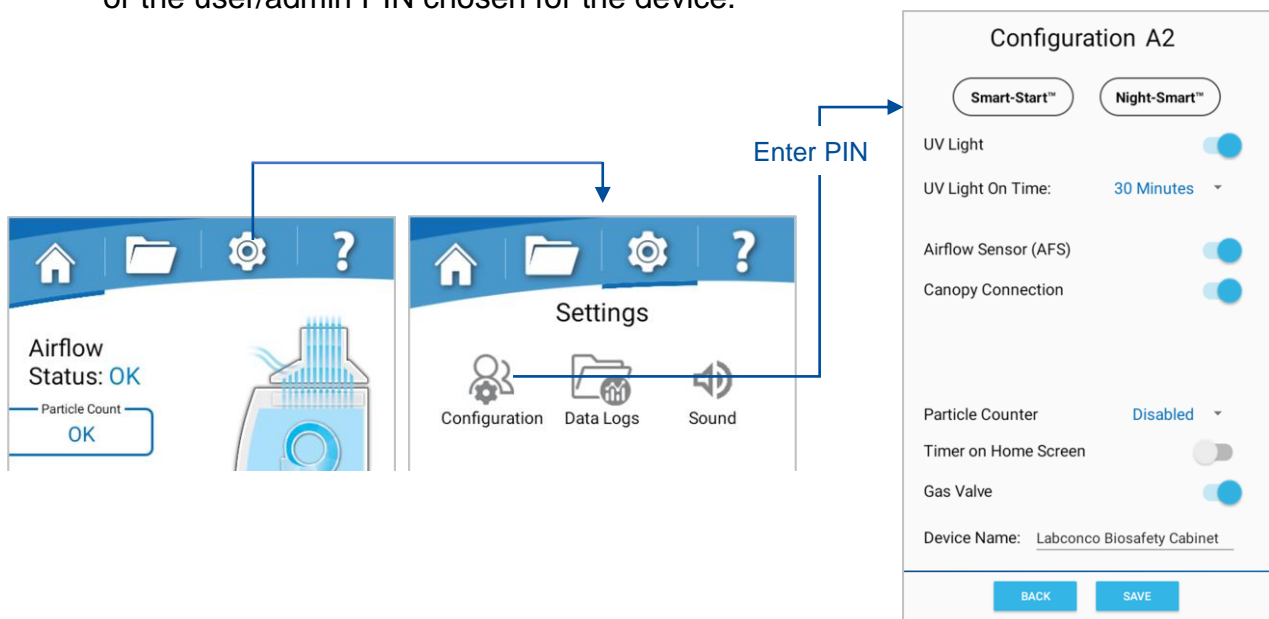


Keypad button presses and screen touches are shown as **[BLUE WITH BRACKETS]**. Menu screen selections are shown as *green italics*.

### Accessing Configuration

The *Configuration Screen* provides information on the current enabled accessories of the biosafety cabinets and details the Smart-Start™/Night-Smart™ automatic operations. The *Configuration Screen* requires a PIN to access. To access this screen, follow these steps:

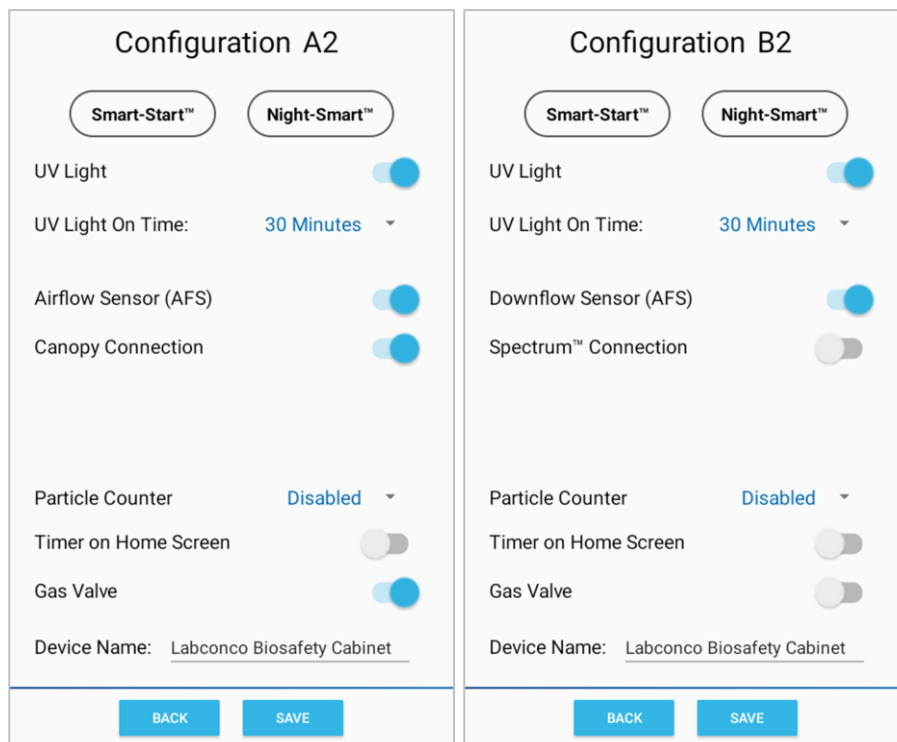
1. From the *Home Screen*, touch **[Settings]** (represented by the gear-icon) on the Menu Bar of the display.
2. Touch **[Configuration]**. When prompted for a security code, enter **[1] [9] [2] [5]** or the user/admin PIN chosen for the device.



Option(s) not installed are shown with a gray disabled toggle switch. To activate, touch the toggle switch by the desired option. It is activated when the toggle switch shows blue. To save any changes, touch **[Save]**. To exit without saving, touch **[Back]**.

If the Airflow Sensor (AFS) is enabled, the zero-point calibration must be conducted with the blower(s) completely off. See [Section 9: Airflow Calibration](#) for detailed instructions.

The Configuration Screens for each cabinet Type are below:



### Setting Automatic Operation (Night-Smart™ / Smart-Start™)

The cabinet allows configuration to activate functions automatically when the sash is opened or closed. The optional automation would control the blower and lights of the cabinet.

To automate the cabinet's Blower or Lights when the sash is raised, touch **[Smart-Start]** in the *Configuration Screen*. The *Smart-Start Screen* shows the currently selected option at the top of the screen. If you want the cabinet Blower to start every time the sash is opened from the closed position, touch the **[Blower On]** icon to activate. The description under *Open Sash* should read 'Start Blower'. If **[Blower Off]** is selected, the blower must be manually started from the keypad. If you want the cabinet Lights to illuminate every time the sash is opened from the closed position, touch the

**[Light On]** icon to activate. The description under *Open Sash* should read '*Light On*'. If **[Light Off]** is selected, the lights must be manually illuminated from the keypad.

To save any changes, touch **[Save]**.

To automate the BSC's Blower or UV Light when the sash is closed, touch **[Night-Smart]** in the *Configuration Screen*.

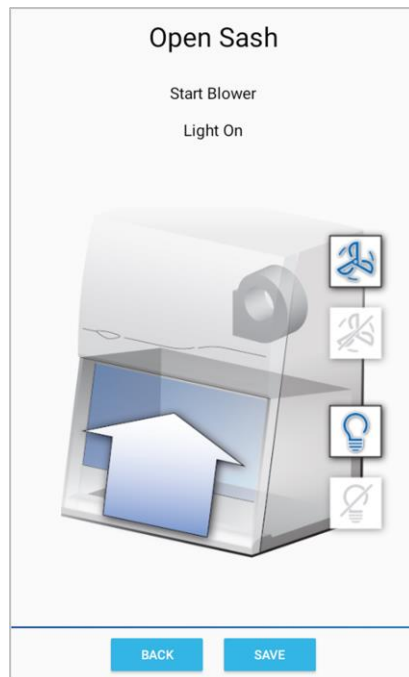


**Note:** the reduced blower feature of Night-Smart is not available on Type B2 cabinets.  
**Note:** the automated UV Light is only available for units with the UV Light installed and enabled.

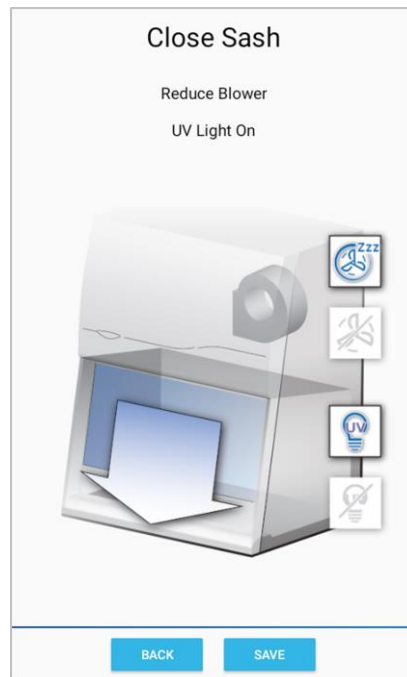
The *Night-Smart Screen* shows the currently selected option at the top of the screen. If you want the cabinet Blower to run slowly, maintaining reduced airflows every time you close the sash, touch the **[Reduce Blower]** icon to activate. The description under *Close Sash* should read '*Reduce Blower*'. If **[Blower Off]** is selected, the blower will stop when the sash is closed. If you want the UV Light to illuminate every time the sash is closed, touch the **[UV Light On]** icon to activate. The description under *Close Sash* should read '*UV Light On*'. If **[UV Light Off]** is selected, the lights must be manually illuminated from the keypad. If your cabinet is not UV Light enabled but Night-Smart's *UV Light On* is activated, the LED Lights will automatically shut off when the sash is closed.

To save any changes made, touch **[Save]**.

*Smart-Start Screen*



*Night-Smart Screen*



## 9: Airflow Calibration

---

This section provides instructions to access and understand the procedures to calibrate the biosafety cabinet. Use this section in conjunction with [Section 10: Certification](#) when performing initial or annual certification.



Keypad button presses and screen touches are shown as **[BLUE WITH BRACKETS]**. Menu screen selections are shown as *green italics*.

### Certifier Password

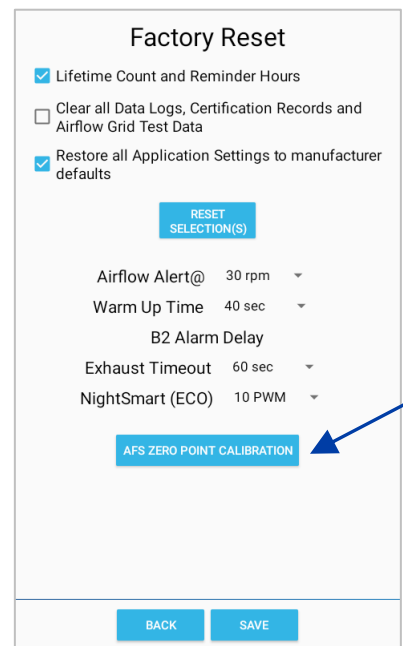
The certifier password is: **[1] [9] [2] [5]**

Use this password for all normal calibration and certification activities.

### Airflow Sensor Zero-Point Calibration

If installing or replacing an Airflow Sensor (AFS), the sensor will need a zero-point calibration. To access the zero-point calibration screen, follow the directions below:

1. Access the *Settings Screen* by touching **[Settings]** (represented by the gear-icon) on the Menu Bar of the display.
2. Touch **[Maintenance]** (represented by the wrench-icon).
3. Touch and hold the top two corners of the display until the screen changes to *Factory Reset*.
4. Locate and touch **[AFS Zero-Point Calibration]** as shown.
5. Follow the prompts on the screen until calibration is complete.
6. To exit *Maintenance* touch **[Back]**. Touch **[Back]** again.



## Adjusting the Internal Air Damper (A2 Models only)

On Type A2 models, it may be necessary to adjust the split of air between downflow and exhaust during the certification of the biosafety cabinet. This is an important part of balancing the biosafety cabinet and achieving the specified average downflow and inflow values for each model and size cabinet.



**Note:** On 8-ft Type A2 models, there are two (2) internal dampers.

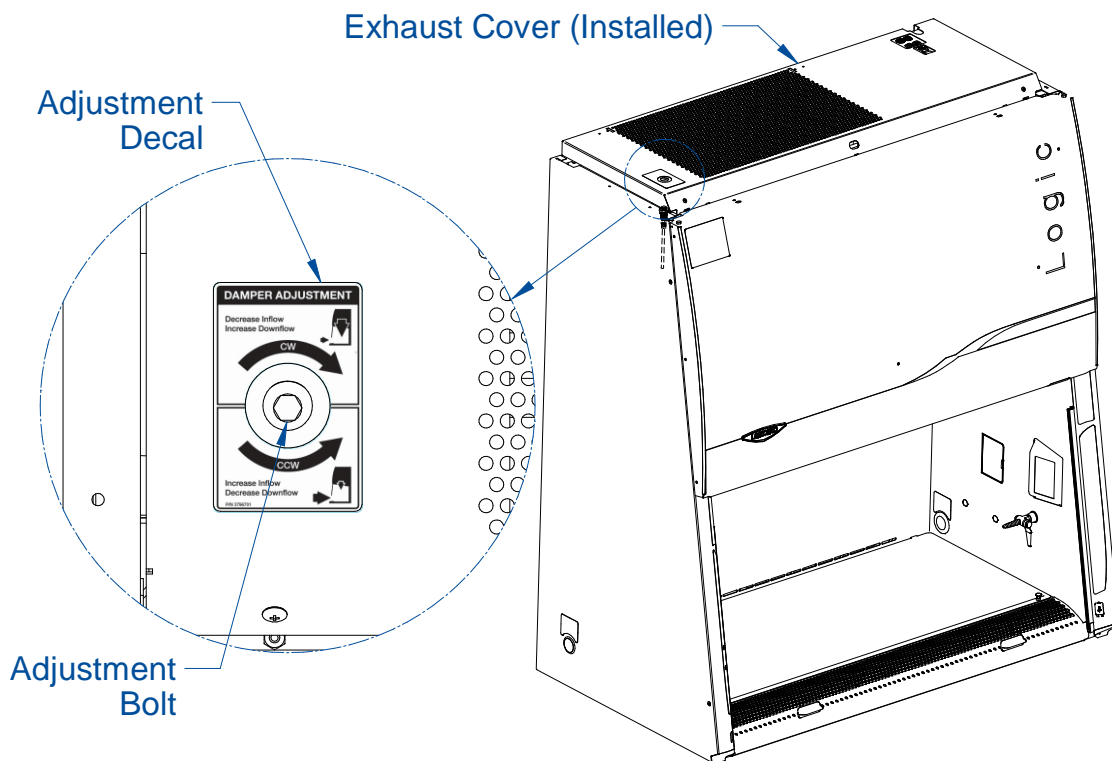


**Note:** On Type B2 (exhausted) models, there is no internal air damper. On Spectrum Blower enabled B2 models, the blower speed of internal blower (for downflow) and the remote Spectrum Blower (for inflow) will be set independently. See the next section *Adjusting Blower Speed* and note the two adjustable Blower PWMs displayed on Step #5.

To adjust the internal damper, follow these instructions:

1. On the top surface of the cabinet, locate the exhaust damper adjustment bolt. It will be in the left corner, close to the front face of the cabinet. It can be accessed with or without the exhaust cover fully installed. Reference Figure 9-1.  
**Note:** If cabinet is an 8-foot Type A2 model, there will be two damper adjustment bolts. One is the left corner, and the second will be closer to the center, near the front face of the cabinet.

**Figure 9-1**



2. Use a 7/16-inch nut driver or socket and ratchet to turn the bolt. The adjustment decal is shown in Figure 9-2.

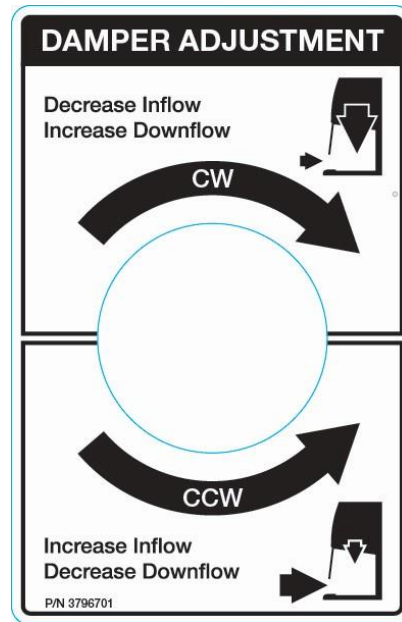
**Figure 9-2**

Turning Clockwise:

- Decreases Inflow (Exhaust)
- Increases Downflow

Turning Counterclockwise:

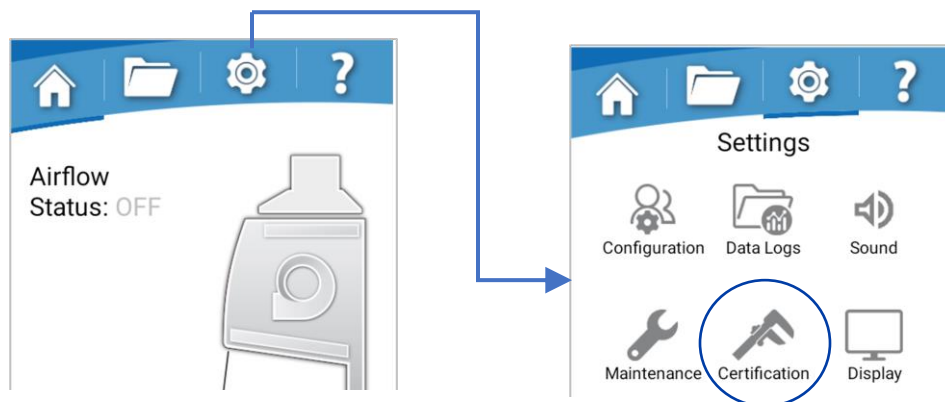
- Increases Inflow (Exhaust)
- Decreases Downflow



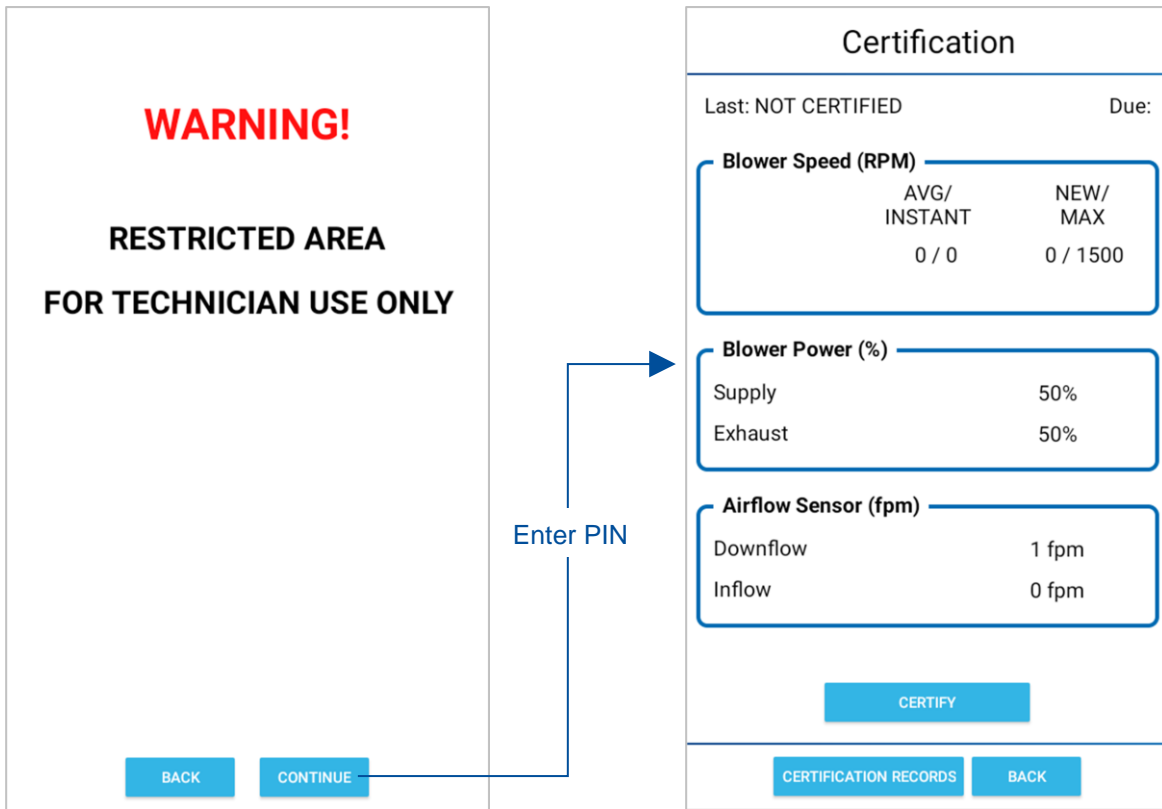
### Adjusting Blower Speed

During initial or annual certification of the biosafety cabinet, the blower speed may need to be adjusted. Blower speed must only be adjusted by a trained, qualified certifier. To adjust the blower speed, following these instructions.

1. Access the *Settings Screen* by touching **[Settings]** (represented by the gear-icon) on the Menu Bar of the display.
2. Locate and touch **[Certification]** (represented by the calipers-icon) on the *Settings Screen*.



- From the *Warning Screen*, touch **[Continue]** to acknowledge the warning that the following screens are restricted.



- When prompted for a password, enter: **[1] [9] [2] [5]**. You will now be in the *Certification* page.



If also installing a new airflow sensor, the zero-point calibration of the airflow sensor needs to be done before airflow calibration. See *Airflow Sensor Zero-point Calibration* earlier in this section to for instructions.



Never enter the password-protected area, or change settings of the biosafety cabinet if you are not a trained and qualified certifier or technician. Changing parameters in the password-protected area may impair the product's performance and result in loss of protection and/or harm or death to personnel in the laboratory.



5. Touch **[Certify]**. When prompted, enter your name/organization and touch **[Next]**. You are now in *Certify Mode*. If not already on, the internal blower(s) will start.

**Note:** The sash must be at operating height when calibrating airflow. See [Section 10: Certification](#) for more information on measuring airflows.

The screenshot shows the 'Certification' screen with the following data and annotations:

Blower Speed (RPM)	
AVG/ INSTANT	NEW/ MAX
287 / 287	0 / 1500

*Average/Instantaneous Blower RPM* (points to the Blower Speed section)

Blower Power (%)	
Supply	50%
Exhaust	50%

*Blower PWM(s)* (points to the Blower Power section)

Only shown on Spectrum Enabled B2s (points to the Blower Power section)

Airflow Sensor (fpm)	
Downflow	55 fpm
Inflow	105 fpm

*AFS Values* (points to the Airflow Sensor section)

Touch this icon for the AFS value(s) to jump to the values as shown. (points to the lightning bolt icon in the Airflow Sensor section)

'Save' displayed as blue when blower speed stabilizes (points to the SAVE button)

Active for adjusting via keypad (points to the Supply field in Blower Power section)

The screen also includes 'Last: NOT CERTIFIED', 'Due:', 'SAVE', 'AIRFLOW GRID', and 'BACK' buttons.

To adjust the blower PWM/AFS value, touch the **[▲]** and **[▼]** on the display or use the **[UP]** or **[DOWN]** keys on the keypad. Only the 'active' field (shown by highlighted BLUE box) can be adjusted via the keypad. To navigate to the next adjustable Blower PWM or AFS value using the keypad, press the **[OK/MUTE]** key. Each single press of **[UP]** or **[DOWN]** increments the PWM signal sent to the blower by 1.

When the Instantaneous Blower rpm is within 15 rpm of the Average Blower rpm, the blower speed has stabilized, and **[Save]** can be touched to move to the next screen.

## (Type B2 Only) Exhaust Airflow Alarm Setpoint

To access the Airflow Sensor Calibration screen(s), follow the steps in *Adjusting the Blower Speed* previously shown in this section. Then follow these instructions:

1. In *Certify*, once the blower(s) stabilize, the airflows are confirmed to be nominal and the AFS(s) are set as measured, touch **[Save]**. The nominal setpoint will be calibrated before the next prompt appears for the inflow alarm set point.
2. Now the alarm set point must be established. The screen below is displayed. While on this screen, reduce the remote or building exhaust system until the **TOTAL** volume of air drawn by the remote exhaust system is reduced to 80% of nominal. For a B2 biosafety cabinet, the remote exhaust system pulls both the downflow air volume AND inflow air volume from the cabinet and exhausts it. If the Spectrum Blower is enabled, the exhaust can be reduced via the **[UP]** or **[DOWN]** keys or touch the **[▲]** and **[▼]** on the display.

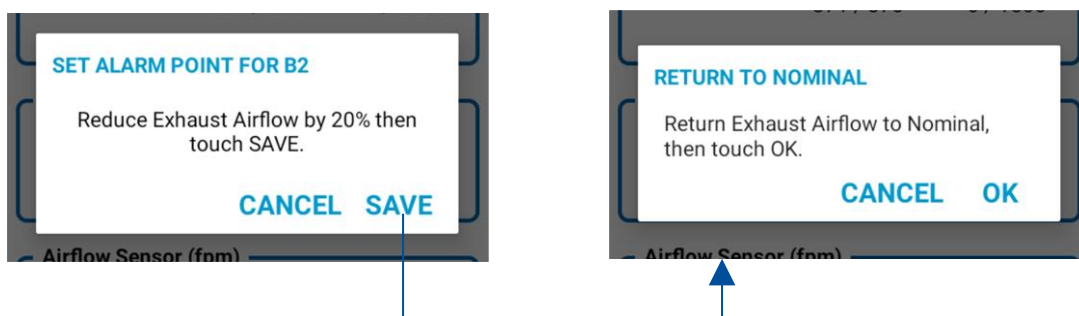
**Table 9-1**

Logic Type B2 Model	Inflow @ 80% Alarm Set Point	
	ft <sup>3</sup> /min	m <sup>3</sup> /hr
4-foot, 8" Sash	136	231
6-foot, 8" Sash	204	347



**Note:** To set alarm point airflow, if unable to measure airflow in the exhaust duct above the biosafety cabinet, slowly close the Air-Tight Damper until the Inflow into the cabinet equals the values in Table 9-1.

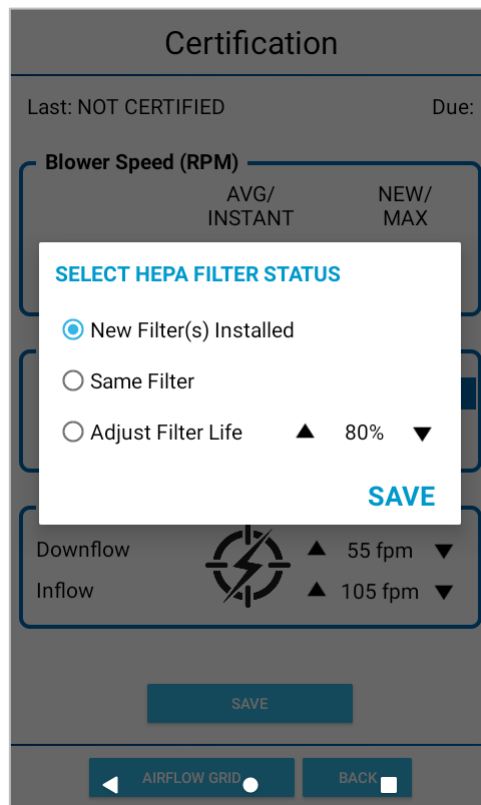
3. Once complete, touch **[Save]**.
4. Restore the remote exhaust system to nominal airflow. If the Spectrum Blower is enabled, it will return to nominal automatically. Touch **[OK]** when complete.



## Setting the Filter Life Status

During initial or annual certification of the biosafety cabinet, and after the HEPA filters are changed, the Filter Life Status may need to be reset.

To access the *Filter Life Status Screen*, follow the steps in *Adjusting the Blower Speed* previously shown in this section. When the blower(s) stabilizes, touch **[Save]**. If the unit is a Type B2, the alarm set-point must be set by following the steps in *(Type B2 Only) Exhaust Airflow Alarm Setpoint* previously shown in this section. When complete, the *Select HEPA Filter Status* pop-up will appear:



There are three options to choose from when resetting the Filter Life Status. Below are the three options, and an explanation on which to select.

1. *New Filter(s) Installed* – Select this option when the HEPA filters are new. This occurs during initial certification of a new biosafety cabinet, or after new HEPA filters are installed and the biosafety cabinet's Inflow and Downflow have been verified by a trained and qualified certifier.
2. *Same Filter* – Select this option when the blower speed(s) have been adjusted slightly (but the HEPA filters have not been replaced) during an annual certification, or an airflow sensor(s) were recalibrated.
3. *Adjust Filter Life* – This option is seldom selected. It may be used to set the Filter Life status to a specific percentage, for example, after the display circuit board is

replaced, and the settings from the previous display board need to be programmed into the new display board.

Once your selection has been made, touch **[Save]**. If on a Type A2 or B2 cabinet, the airflow calibration is complete. Once all calibrating is complete, you will be routed back to the *Home Screen*.

## 10: Certification

---

This section provides instructions to certify the biosafety cabinet. Use this section in conjunction with [Section 9: Calibration](#) when performing initial or annual certification.



Never enter the password-protected area, or change settings of the biosafety cabinet if you are not a trained and qualified certifier or technician. Changing parameters in the password-protected area may impair the product's performance and result in loss of protection and/or harm or death to personnel in the laboratory.

### Certifier Password

The certifier password is: **[1] [9] [2] [5]**

Use this password for all normal calibration and certification activities.

### Type A2 HEPA Filter Leak Test Preparation

All biosafety cabinet models were tested to the HEPA Filter Leak Test as described in the current NSF/ANSI Standard 49. This section describes the methods, specifications, and Pass/Fail criteria to challenge each HEPA filter in the biosafety cabinet.



You never know what a biosafety cabinet has been exposed to, so it is always recommended to surface decontaminate any components prior to working inside the biosafety cabinet and/or removing components from the biosafety cabinet.



**Note:** All 8-foot Type A2 Models have two (2) sets of filters. When filter leak testing 8-foot cabinets, each set must be scanned individually. For the 8-foot only, follow the entire instructions below on one side, before repeating all steps again on the remaining side. *Notes for 8-foot filter leak testing are included in italics throughout the subsection.*

1. Remove the work surface(s) by lifting the handles on either end. Pull the work surface(s) straight out of the biosafety cabinet.
2. Turn the blower(s) of the biosafety cabinet on.
3. Ensure that the generator is level, and the oil level is within 1/8 inch (3 mm) of the level line. Place the aerosol generator on the left end of the biosafety cabinet's drip pan, see Figure 10-2. *If 8-foot Model, place the generator in the right, rear corner to scan the right-hand set of filters and the left, rear corner to scan the left-hand set of filters.*
4. If the model has pre-filter(s) installed on the towel catch(es), remove for testing.
5. If the aerosol generator requires pressurized air, connect the air line. Turn on the appropriate number of Laskin nozzles for the model under test based on Table 10-1 to ensure they are each working properly.

6. Verify the generator's air pressure is 23 psi.
7. Turn on the photometer and allow it to operate for a minimum of 5 minutes. Leave the valve in the "CLEAR" setting.

### Theoretical Upstream Concentration

If the biosafety cabinet has been used with biohazards, toxic chemicals, or radioisotopes, the Upstream Sample Tube cannot be used (Figure 10-1). Table 10-1 shows the calculated concentrations for Type A2 models. Establish the 100% and 0% concentration levels for the photometer using the calculated values provided in Table 10-1 for the model being tested.

### Upstream Concentration Sampling

If the biosafety cabinet has **NOT** been used with biohazards, toxic chemicals, or radioisotopes, the Upstream Sample Tube can be used (Figure 10-1).



You never know what a biosafety cabinet has been exposed to, so it is always recommended to surface decontaminate any components prior to working inside the biosafety cabinet and/or removing components from the biosafety cabinet.

1. Locate the Upstream Sample Tube on the right side, protruding from the rear baffle. See Figure 10-1. *If testing an 8-foot Type A2 model, there will be a second Upstream Sample Tube in the center of the cabinet, protruding from the rear baffle. Use the right Upstream Sample Tube for scanning the right-hand filters, and the center Upstream Sample Tube for the left-hand filters.*
2. Pull the Upstream Sample Tube forward. Do not remove the cap yet.
3. When prompted by the photometer, turn on the appropriate number of Laskin nozzles on the aerosol generator, uncap the Upstream Sampling Tube and sample the upstream concentration to establish the 100% concentration level.
4. Establish the 0% concentration level according to your photometer's instructions.

**Figure 10-1**



**Figure 10-2**



**Table 10-1**

Type A2 Cabinet Width	Sash Height (inches)	Air Displacement (CFM)	Laskin Nozzles Required	Calculated Concentration (ug/L) <sup>1</sup>
3-foot	8	552	2	49
	9	576	2	47
	10	600	2	45
	12	648	2	42
4-foot	8	733	2	37
	9	765	2	35
	10	797	2	34
	12	862	3	47
5-foot	8	915	3	44
	9	954	3	42
	10	994	3	41
	12	1075	3	38
6-foot	8	1096	3	37
	9	1144	3	35
	10	1191	3	34
	12	1228	3	33
8-foot <sup>3</sup>	8	746	2	36
	10	810	2	33

1. The calculated concentration was established using the formula:  
Concentration (ug/l) = (# Laskin nozzles @ 23 PSIG x 13,500) / Volume of air displaced
2. Based on Mineral oil
3. All 8-foot Type A2 Models have two (2) sets of filters. When filter leak testing 8-foot cabinets, each set of filters must be scanned individually. The data in Table 10-1 is for each set of filters, not the sum of both filter sets.

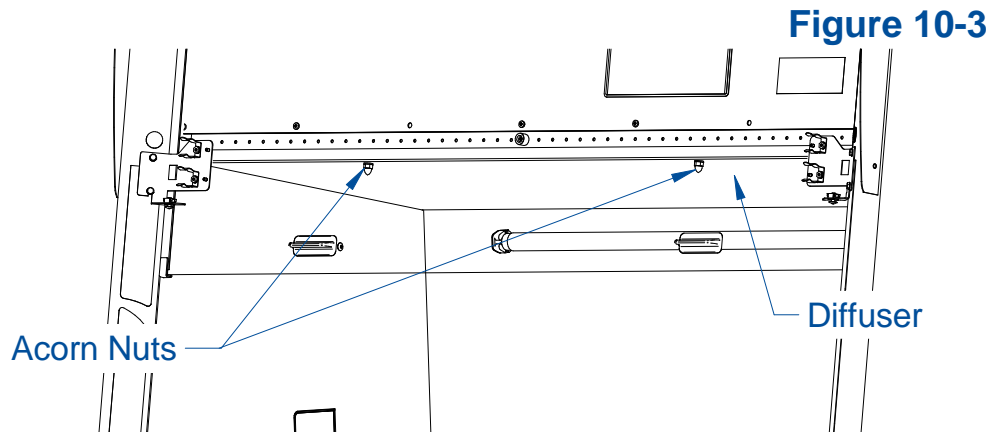
### Type A2 Supply HEPA Filter Leak Test

During this test the supply HEPA filter will be challenged and scanned to check for leaks. This section describes how to access and test the supply HEPA filter on a Type A2 biosafety cabinet. The aerosol generator and photometer should be prepared at this point as described in the preparation steps listed in the previous section.



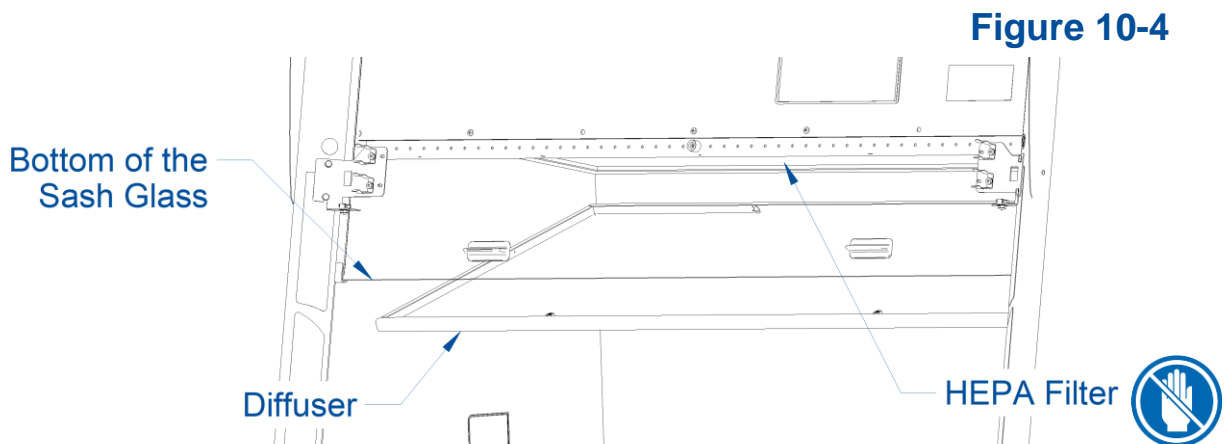
**Note:** All 8-foot Type A2 Models have two (2) sets of filters. When filter leak testing 8-foot cabinets, each set must be scanned individually. For the 8-foot only, follow the entire instructions below on one side, before repeating all steps again on the remaining side. *Notes for 8-foot filter leak testing are included in italics throughout the subsection.*

1. Raise the glass sash as high as it will go.
2. Using a 7/16 inch nut driver or socket and ratchet, remove the two acorn nuts along the front of the diffuser(s). See Figure 10-3. Note: Dress Panel and LED lamps removed for clarity.



**Note:** The diffuser acorn nuts are secured to the studs with a removable thread locking compound to prevent them from vibrating loose during shipment. There may be some resistance the first time the nuts are removed; this is normal. No additional thread locking compound need be applied to these acorn nuts unless the unit is being prepared for shipment.

3. Lower the front edge of the diffuser(s) until it clears the bottom of the sash, then pull the diffuser(s) straight out of the biosafety cabinet. See Figure 10-4.



4. The supply HEPA filter is now ready to be scanned. Set the photometer sampling valve to “DOWNSTREAM”. Ensure proper vacuum at the sampling nozzle.
5. Open the correct number of Laskin Nozzles on the aerosol generator (refer to Table 10-1).
6. Scan the downstream side of the supply HEPA filter by passing the sampling nozzle in slightly overlapping strokes over the entire surface of the filter. The

sampling nozzle must be no more than 1 inch from the surface of the filter media. Scan at a traverse rate of not more than 2 inches per second. *For 8-foot Type A2 models, ensure the filter being scanned (right vs left) corresponds to the side the upstream concentration was taken from.*

7. Scan the entire periphery of the supply HEPA filter, including the gasket between the filter frame and the biosafety cabinet structure.



**Note:** When scanning the front edge of the supply HEPA filter, photometer operation may become erratic due to the aspiration of room air into the front of the work area. This problem can be minimized or eliminated by placing the edge of a sheet of rigid plastic or metal just outside the edge of the HEPA filter when scanning the front edge. See Figure 10-5 as reference.

**Figure 10-5**

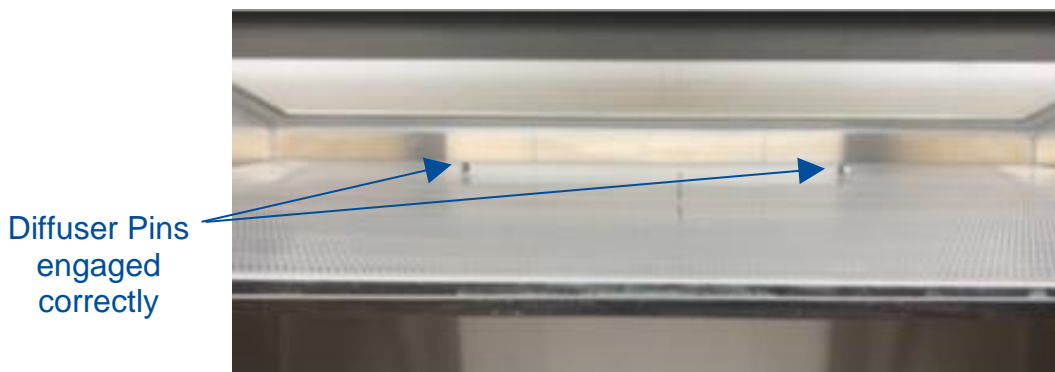


#### Acceptance Criteria

Aerosol penetration shall not exceed 0.01%.

Reinstall the diffuser, ensuring the two holes in the back of the diffuser frame engage the posts on the rear wall of the cabinet. See Figure 10-6 for reference. *For 8-foot Type A2 models, only reinstall the diffusers when both supply filters have been scanned.*

**Figure 10-6**



## Type A2 Exhaust HEPA Filter Leak Test

During this test the exhaust HEPA filter will be challenged and scanned to check for leaks. This section describes how to access and test the exhaust HEPA filter on a Type A2 biosafety cabinet. The aerosol generator and photometer should be prepared at this point as described in the preparation steps listed in the previous section.

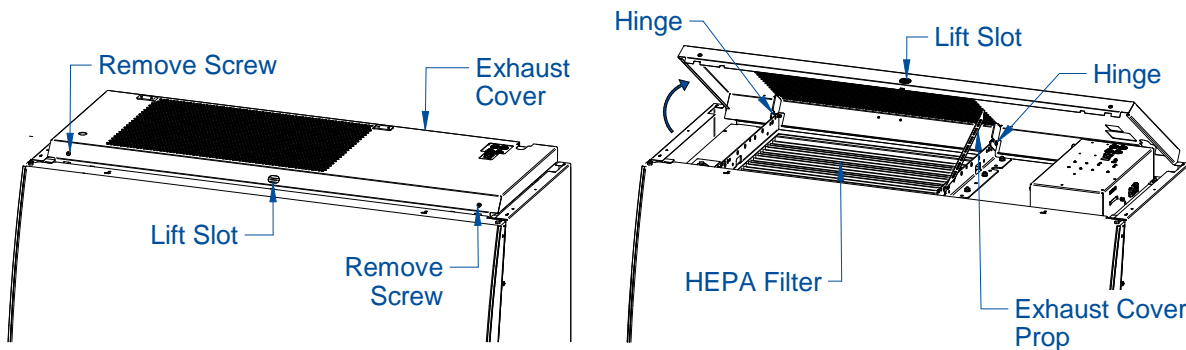


**Note:** All 8-foot Type A2 Models have two (2) sets of filters. When filter leak testing 8-foot cabinets, the sets must be scanned one at a time. For the 8-foot only, follow the entire instructions below on one side, before repeating all steps again on the remaining side. *Notes for 8-foot filter leak testing are included in italics throughout the subsection.*

Before starting, examine the clearance between the top of the biosafety cabinet and the ceiling or any overhead obstructions. If there is 18 inches (46 cm) or more of overhead clearance, follow the procedure below to hinge the exhaust cover open. If there is not enough clearance, remove the exhaust cover altogether.

1. Remove the two phillips screws in the front of the cover(s) shown in Figure 10-7.
2. Hinge the cover(s) up from the front using the lift slot.
3. If full removal is not needed, skip to the next step. To remove the exhaust cover(s), pull the slightly lifted exhaust cover(s) forward, until the hinges (reference Figure 10-7) of the cover(s) are free from the cabinet. Once free, carefully pull away and lower from the cabinet. Store safely.
4. If leaving the cover(s) installed, the exhaust cover(s) can be secured in the lifted position by using the exhaust cover prop. Rotate the prop up and against the exhaust cover. Insert the end of the prop(s) into the exhaust cover perforations to keep the cover(s) lifted to height required for servicing. Reference Figure 10-7. Carefully lower the exhaust cover(s) onto the prop and release when stable. Do not release the exhaust cover if the prop is not fully in place against the cover(s).

**Figure 10-7**



The exhaust HEPA filter media is now exposed. Never touch the media, it is easily damaged.

5. The exhaust HEPA filter is now ready to be scanned. Set the photometer sampling valve to “DOWNSTREAM”. Ensure proper vacuum at the sampling nozzle.
6. Open the correct number of Laskin Nozzles on the aerosol generator (refer to Table 10-1).
7. Scan the downstream side of the exhaust HEPA filter by passing the sampling nozzle in slightly overlapping strokes over the entire surface of the filter. The sampling nozzle must be no more than 1 inch from the surface of the filter media. Scan at a traverse rate of not more than 2 inches per second. *For 8-foot Type A2 models, ensure the filter being scanned (right vs left) corresponds to the side the upstream concentration was taken from.*
8. Scan the entire periphery of the exhaust HEPA filter, including the gasket between the filter frame and the biosafety cabinet structure.



**Note:** When scanning the edges of the exhaust HEPA filter, photometer operation may become erratic due to the aspiration of room air into the exhaust air stream. This problem can be minimized or eliminated by placing the edge of a sheet of rigid plastic or metal just outside the edge of the HEPA filter when scanning the filter edges. See Figure 10-8 as reference.

**Figure 10-8**



#### Acceptance Criteria

Aerosol penetration shall not exceed 0.01%.

Replace and secure the exhaust cover and its screws.

## Type B2 Supply HEPA Filter Leak Test Preparation

All biosafety cabinet models were tested to the HEPA Filter Leak Test as described in the current NSF/ANSI Standard 49. This section describes the methods, specifications, and Pass/Fail criteria to challenge the supply HEPA filter in the biosafety cabinet.



You never know what a biosafety cabinet has been exposed to, so it is always recommended to surface decontaminate any components prior to working inside the biosafety cabinet and/or removing components from the biosafety cabinet.

1. Remove the work surface by lifting the handles on either end. Pull the work surface straight out of the biosafety cabinet.
2. Turn the blower of the biosafety cabinet on.
3. Check the oil level of the aerosol generator is within 1/8 inch (3 mm) of the level line.
4. If the aerosol generator requires pressurized air, connect the air line.
5. Verify the generator's air pressure is 23 psi.
6. Turn on the photometer and allow it to operate for a minimum of 5 minutes. Leave the valve in the "CLEAR" setting.

## Theoretical Upstream Concentration

If you do not wish to connect the Upstream Sampling Tube to the photometer to establish the actual 100% concentration value, the theoretical value will need to be used instead. Table 10-2 shows the actual vs calculated concentrations for Type B2 models. Establish the 100% and 0% concentration levels for the photometer using the calculated values provided in Table 10-2 for the model being tested.



## Upstream Concentration Sampling

You never know what a biosafety cabinet has been exposed to, so it is always recommended to surface decontaminate any components prior to working inside the biosafety cabinet and/or removing components from the biosafety cabinet.

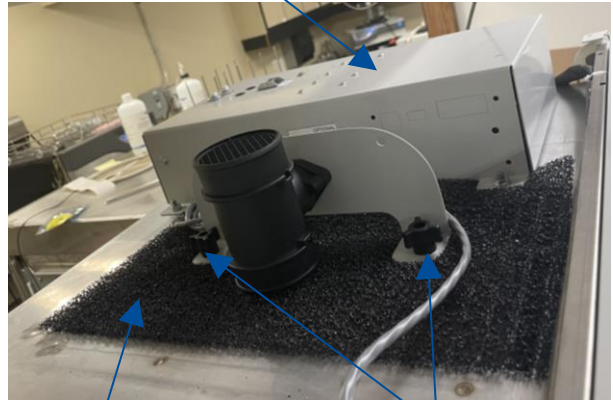
1. Locate the Upstream Sample Tube on the right side, protruding from the rear baffle. See Figure 10-9.
2. Pull the Upstream Sample Tube forward. Do not remove the cap yet.
3. Place the aerosol generator on top of the biosafety cabinet, see Figure 10-10.
4. Remove the inlet pre-filter and airflow sensor assembly (Figure 10-10).
5. When prompted by the photometer, turn on the appropriate number of Laskin nozzles on the aerosol generator (see Table 10-2), uncap the Upstream Sampling Tube and sample the upstream concentration to establish the 100% concentration level.
6. Establish the 0% concentration level according to your photometer's instructions.

**Figure 10-9**



Place aerosol generator here

**Figure 10-10**



Pre-Filter

Thumbnuts (2)

**Table 10-2**

Type B2 Cabinet Width	Sash Height (inches)	Supply Air Displacement (CFM)	Laskin Nozzles Required	Calculated Concentration (ug/L) <sup>1</sup>
4-foot	8	450	1	30
6-foot	8	673	1	20

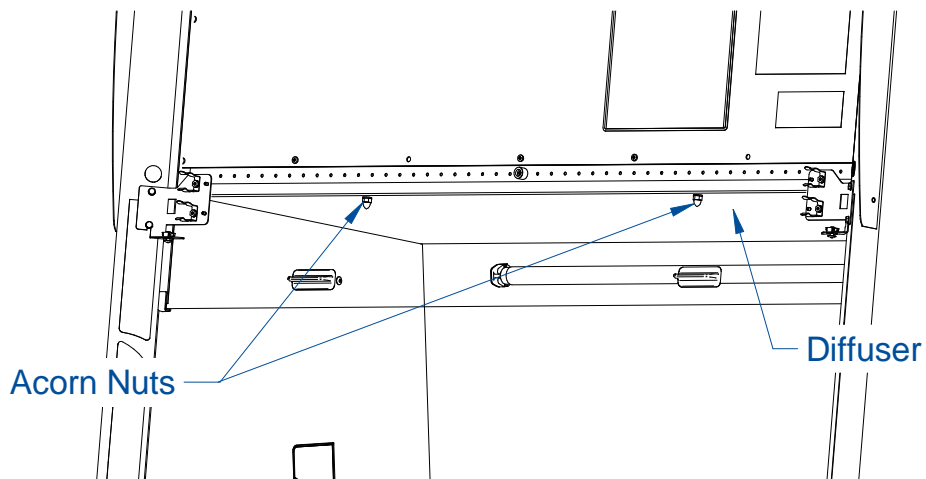
1. The calculated concentration was established using the formula:  
 $\text{Concentration (ug/l)} = (\# \text{ Laskin nozzles @ 23 PSIG} \times 13,500) / \text{Volume of air displaced}$
2. Based on Mineral oil

## Type B2 Supply HEPA Filter Leak Test

During this test the supply HEPA filter will be challenged and scanned to check for leaks. This section describes how to access and test the supply HEPA filter on a Type B2 biosafety cabinet. The aerosol generator and photometer should be prepared at this point as described in the preparation steps listed in the previous section.

1. Raise the glass sash as high as it will go.
2. Using a 7/16 inch nut driver or socket and ratchet, remove the two acorn nuts along the front of the diffuser. See Figure 10-11. Note: Dress Panel and LED lamps removed for clarity.

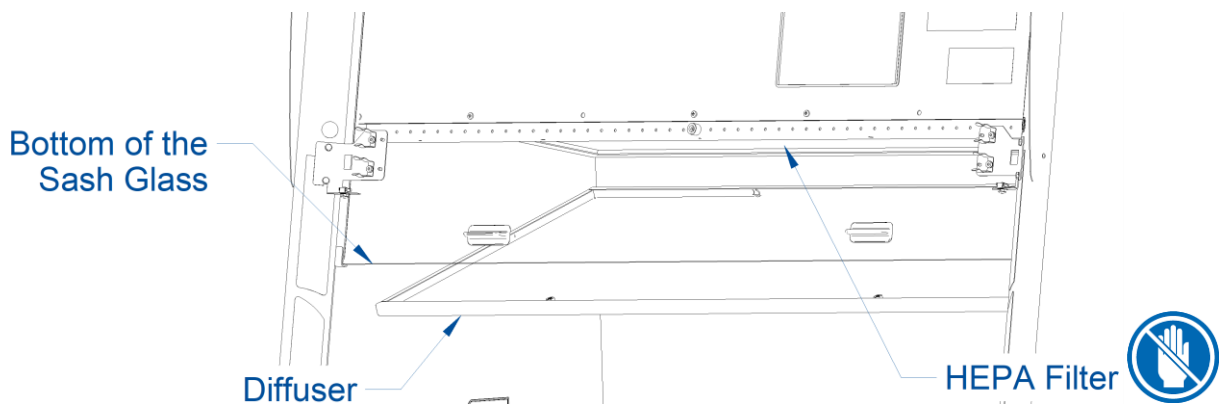
**Figure 10-11**



**Note:** The diffuser acorn nuts are secured to the studs with a removable thread locking compound to prevent them from vibrating loose during shipment. There may be some resistance the first time the nuts are removed; this is normal. No additional thread locking compound need be applied to these acorn nuts unless the unit is being prepared for shipment.

3. Lower the front edge of the diffuser until it clears the bottom of the sash, then pull the diffuser straight out of the biosafety cabinet. See Figure 10-12.

**Figure 10-12**



4. The supply HEPA filter is now ready to be scanned. Set the photometer sampling valve to “DOWNSTREAM”. Ensure proper vacuum at the sampling nozzle.
5. Open the correct number of Laskin Nozzles on the aerosol generator (refer to Table 10-2).
6. Scan the downstream side of the supply HEPA filter by passing the sampling nozzle in slightly overlapping strokes over the entire surface of the filter. The sampling nozzle must be no more than 1 inch from the surface of the filter media. Scan at a traverse rate of not more than 2 inches per second.
7. Scan the entire periphery of the supply HEPA filter, including the gasket between the filter frame and the biosafety cabinet structure.



**Note:** When scanning the front edge of the supply HEPA filter, photometer operation may become erratic due to the aspiration of room air into the front of the work area. This problem can be minimized or eliminated by placing the edge of a sheet of rigid plastic or metal just outside the edge of the HEPA filter when scanning the front edge. See Figure 10-13 as reference.

**Figure 10-13**



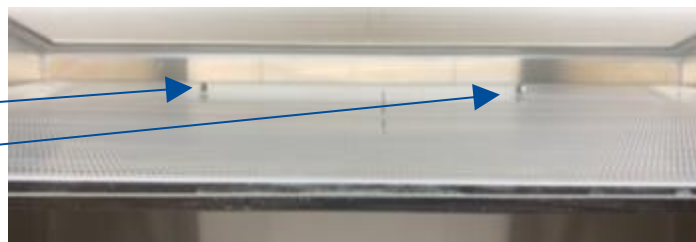
#### Acceptance Criteria

Aerosol penetration shall not exceed 0.01%.

Reinstall the inlet pre-filter, airflow sensor assembly and diffuser, ensuring the two holes in the back of the diffuser frame engage the posts on the rear wall of the cabinet. See Figure 10-14 for reference.

**Figure 10-14**

Diffuser Pins  
engaged  
correctly



## Type B2 Exhaust HEPA Filter Leak Test Preparation

All biosafety cabinet models were tested to the HEPA Filter Leak Test as described in the current NSF/ANSI Standard 49. This section describes the methods, specifications, and Pass/Fail criteria to challenge the exhaust HEPA filter in the biosafety cabinet.



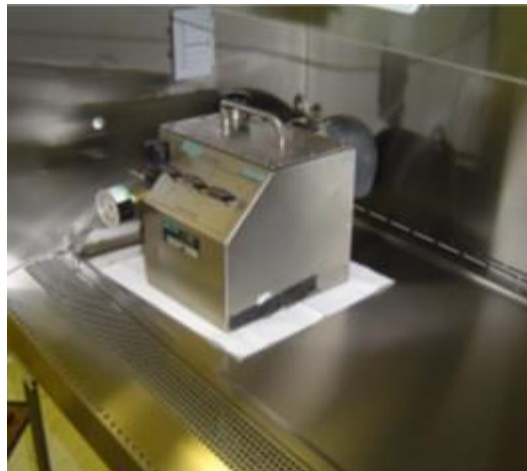
You never know what a biosafety cabinet has been exposed to, so it is always recommended to surface decontaminate any components prior to working inside the biosafety cabinet and/or removing components from the biosafety cabinet.

1. Remove the work surface by lifting the handles on either end. Pull the work surface straight out of the biosafety cabinet.
2. Turn the blower of the biosafety cabinet on.
3. Place the aerosol generator in the left, rear corner of the biosafety cabinet's drip pan, see Figure 10-15. Ensure that the generator is level, and the oil level is within 1/8 inch (3 mm) of the level line.
4. If the aerosol generator requires pressurized air, connect the air line.
5. Verify the generator's air pressure is 23 psi.
6. Turn on the photometer and allow it to operate for a minimum of 5 minutes. Leave the valve in the "CLEAR" setting.

### Theoretical Upstream Concentration

Actual upstream sampling is not possible on a Type B2 exhaust filter, so the theoretical concentration will be used. Table 10-3 shows the calculated concentrations for Type B2 models. Establish the 100% and 0% concentration levels for the photometer using the calculated values provided in Table 10-3 for the model being tested.

**Figure 10-15**



**Table 10-3**

Type B2 Cabinet Width	Sash Height (inches)	Exhaust Air Displacement (CFM)	Laskin Nozzles Required	Calculated Concentration (ug/L) <sup>1</sup>
4-foot	8	695	2	39
6-foot	8	1175	2	23

1. The calculated concentration was established using the formula:  
Concentration (ug/l) = (# Laskin nozzles @ 23 PSIG x 13,500) / Volume of air displaced
2. Based on Mineral oil

### Type B2 Exhaust HEPA Filter Leak Test

During this test the exhaust HEPA filter will be challenged and a downstream average utilized to check for leaks. This section describes how to test the exhaust HEPA filter on a Type B2 biosafety cabinet. The aerosol generator and photometer should be prepared at this point as described in the preparation steps listed in the previous section.

1. Locate a sampling port downstream of the exhaust HEPA filter. The sampling port is not part of the biosafety cabinet. It must be facility supplied as part of the facility's exhaust system ducting. The sampling port should ideally be at least 10 duct diameters downstream of the exhaust HEPA filter, and the same distance from any elbows in the duct work.
2. Connect the sampling port to the photometer.
3. Set the photometer sampling valve to "DOWNSTREAM". Ensure proper vacuum at the sampling tube.
4. Open the appropriate number of Laskin nozzles on the aerosol generator (see Table 10-3).
5. Observe the average concentration of aerosol downstream.

### Acceptance Criteria

Aerosol penetration shall not exceed 0.005%.

Reinstall the work surface.

## Downflow Velocity

All models of Labconco biosafety cabinets are classified as uniform downflow, as tested per the current NSF Standard 49. This section describes how to prepare and test the downflow velocity on all Types of biosafety cabinets.



Before setting up the downflow velocity test, if any accessories are installed inside the biosafety cabinet (UV lamp, IV Bar, etc.), remove them for this test. Ensure sash is at the correct operating height, and remote (building) exhaust is on (if exhaust connected).



On all biosafety cabinet types and models, the downflow test points are to be taken at a height of **4 inches (10 cm) above the bottom edge of the glass sash**.



**The thermal anemometer probe should always point toward the nearest side wall or the sash, whichever is closer to the probe.** Therefore, on the two rear rows, the probe should point to the left side wall when taking the left half of test points, and the right side wall when taking the right half of test points. And, on the front row, the probe should always point forward towards the glass sash. See Figures 10-26 and 10-27 for reference.

**Figure 10-26**



**Figure 10-27**



The thermal anemometer probe stand shown in the above figures is available from Labconco. The catalog number for the stand is 3858410.



Set the thermal anemometer's **time constant to 10 or 15 seconds** for greater data stability.

1. For the Type and sash height biosafety cabinet under test, set up the test grid based on the dimensions provided in Table 10-6. Start the blower(s).

**Table 10-6**

Type A2 Cabinet Width	Sash Height	Downflow Average <sup>1</sup>	Test Grid		Distance in inches (cm)		
	inches	FPM (m/s)	Total Test Points	Rows x Columns	From Back & Sides	Between Rows	Between Columns
3-foot	8, 9	55 (.28)	21	3 x 7	6.0 (15)	5.80 (14.7)	4.08 (10.4)
	10	55 (.28)	21	3 x 7	6.0 (15)	5.61 (14.3)	4.08 (10.4)
	12	55 (.28)	21	3 x 7	6.0 (15)	5.44 (13.8)	4.08 (10.4)
4-foot	8, 9	55 (.28)	24	3 x 8	6.0 (15)	5.80 (14.7)	5.21 (13.2)
	10	55 (.28)	24	3 x 8	6.0 (15)	5.61 (14.3)	5.21 (13.2)
	12	55 (.28)	24	3 x 8	6.0 (15)	5.44 (13.8)	5.21 (13.2)
5-foot	8, 9	55 (.28)	30	3 x 10	6.0 (15)	5.80 (14.7)	5.39 (13.7)
	10	55 (.28)	30	3 x 10	6.0 (15)	5.61 (14.3)	5.39 (13.7)
	12	55 (.28)	30	3 x 10	6.0 (15)	5.44 (13.8)	5.39 (13.7)
6-foot	8, 9	55 (.28)	36	3 x 12	6.0 (15)	5.80 (14.7)	5.50 (14.0)
	10	55 (.28)	36	3 x 12	6.0 (15)	5.61 (14.3)	5.50 (14.0)
	12	50 (.25)	36	3 x 12	6.0 (15)	5.44 (13.8)	5.50 (14.0)
8-foot	8	55 (.28)	48	3 x 16	6.0 (15)	5.80 (14.7)	5.21 (13.2)
	10	55 (.28)	48	3 x 16	6.0 (15)	5.61 (14.3)	5.21 (13.2)
Type B2 Cabinet Width	Sash Height	Downflow Average <sup>1</sup>	Test Grid		Distance in inches (cm)		
	inches	FPM (m/s)	Total Test Points	Rows x Columns	From Back & Sides	Between Rows	Between Columns
4-foot	8	55 (.28)	24	3 x 8	6.0 (15)	5.80 (14.7)	5.21 (13.2)
6-foot	8	55 (.28)	36	3 x 12	6.0 (15)	5.80 (14.7)	5.50 (14.0)

1. Tolerance for Average Downflow Velocity = +/- 5 FPM (+/- 0.03 m/s)
2. Take the downflow velocity reading at each test point location of the test grid.
3. Average all individual test point velocity readings.
4. If the average is not within the acceptance criteria range, adjust the biosafety cabinet according to *Adjusting the Blower Speed* and/or *Adjusting the Internal Damper* found in [Section 9: Calibration](#).

**Acceptance Criteria**

Average downflow shall be as specified in Table 10-6 column “Downflow Average” +/-5 FPM (+/-0.03 m/s), and all individual test points within +/-16 FPM (+/-0.081 m/s) from the average.

## Inflow Velocity

All models of Labconco biosafety cabinets are tested per the current NSF/ANSI Standard 49. This section describes how to prepare and test the inflow velocity on all Types of biosafety cabinets.



The front Dress Panel must be installed on the biosafety cabinet to obtain accurate inflow results. If the biosafety cabinet is connected to a remote (building) exhaust system, ensure the remote exhaust system is on.

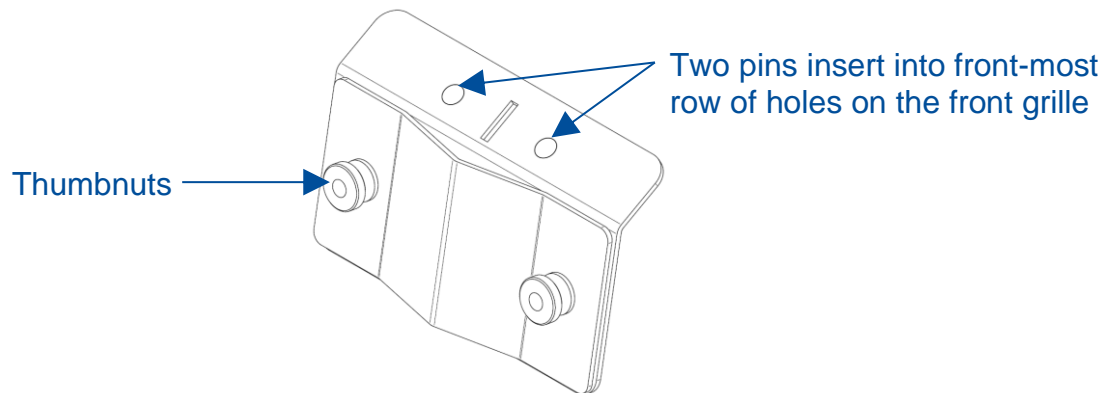
## Primary Method

NSF/ANSI Standard 49 now requires the Primary Method for determining inflow be utilized unless there is less than 41 inches (104 cm) clearance between the front of the biosafety cabinet and the nearest physical, permanent obstruction.

The Primary Method requires the following:

- DIM (Direct Inflow Meter), such as a Shortridge™
- Labconco Holder Bracket Assembly (Labconco Part No 3836405, in Labconco Certifier Kit Part No 3858400), shown below in Figure 10-28.
- Thin, rigid plastic (or similar material) blocking plates, to close off front work opening on either side of the DIM so all inflow air is directed through the DIM.
- Removable tape to secure the plastic blocking plates.

**Figure 10-28**



1. Start the blower(s), ensure the sash is at the correct operating height.
2. Attach the Labconco Holder Bracket Assembly to the front grille using the two pins (reference Figure 10-28) centered left-to-right on the biosafety cabinet. Loosen the two Thumbnuts to create a gap between the two plates.
3. Place the DIM's skirt frame into the gap between the two plates on the Bracket Assembly.

4. Lower the sash until the skirt frame rests on the inside of the glass and remains in place. A tall stand may be used to support the opposite end of the DIM if desired.
5. If a sash alarm occurs, press **[OK/MUTE]**. If in Certify Mode (reference *Adjusting Blower Speed* found in [Section 9: Airflow Calibration](#)), the sash alarm will be disabled until the airflow calibration process is completed or quit.
6. Install a blocking plate on either side of the DIM, and tape them securely on all four sides. All air should enter through the DIM, seal gaps around blocking plates completely.
7. Turn on the DIM, set it to read airflow volume continuously.
8. Take 5 readings over a 1 minute period. Average the results.
9. Compare results with column “Inflow Volume Range” based on Type and model shown in Table 10-7.
10. If the Inflow Volume is not within the acceptance criteria range, adjust the biosafety cabinet according to *Adjusting Blower Speed* and/or *Adjusting the Internal Damper* found in [Section 9: Airflow Calibration](#).

**Table 10-7**

Type A2 & B2 Cabinet Width	Sash Height	Inflow Average <sup>1</sup>	Sash Open Area		Inflow Volume	Inflow Volume Range	
	inches	FPM (m/s)	ft <sup>2</sup>	m <sup>2</sup>	CFM	CFM	m <sup>3</sup> /hr
3-foot	8	105	2.03	0.19	213	203-223	345-379
	9	105	2.28	0.21	240	228-251	387-426
	10	105	2.53	0.24	266	253-278	430-472
	12	105	3.04	0.28	319	304-335	516-569
4-foot	8	105	2.69	0.25	283	269-296	457-503
	9	105	3.03	0.28	318	303-333	515-566
	10	105	3.37	0.31	354	337-371	573-630
	12	105	4.04	0.38	424	404-444	686-754
5-foot	8	105	3.36	0.31	353	336-370	571-629
	9	105	3.78	0.35	397	378-416	642-707
	10	105	4.20	0.39	441	420-462	714-785
	12	105	5.04	0.47	530	505-555	858-943
6-foot	8	105	4.03	0.37	423	403-443	685-753
	9	105	4.53	0.42	476	453-498	770-846
	10	105	5.03	0.47	529	503-553	855-940
	12	105	6.04	0.56	634	604-665	1025-1129
8-foot	8	105	5.48	0.51	575	548-603	931-1025
	10	105	6.85	0.64	719	685-753	1164-1279

1. Tolerance for Average Inflow Velocity = +/- 5 FPM (+/- 0.03 m/s)

**Acceptance Criteria**

Inflow Volume shall be in the range specified in Table 10-7 column “Inflow Volume Range”.

### Secondary Method

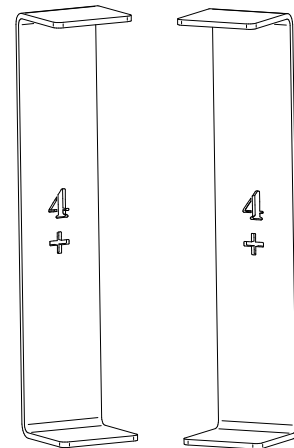
NSF/ANSI Standard 49 now requires the Primary Method for determining inflow be utilized unless there is less than 41 inches (104 cm) clearance between the front of the biosafety cabinet and the nearest physical, permanent obstruction. If there is less than 41 inches (104 cm) between the front of the biosafety cabinet and the nearest physical, permanent obstruction, the Secondary Method for measuring inflow may be used.

The Secondary Method requires the following:

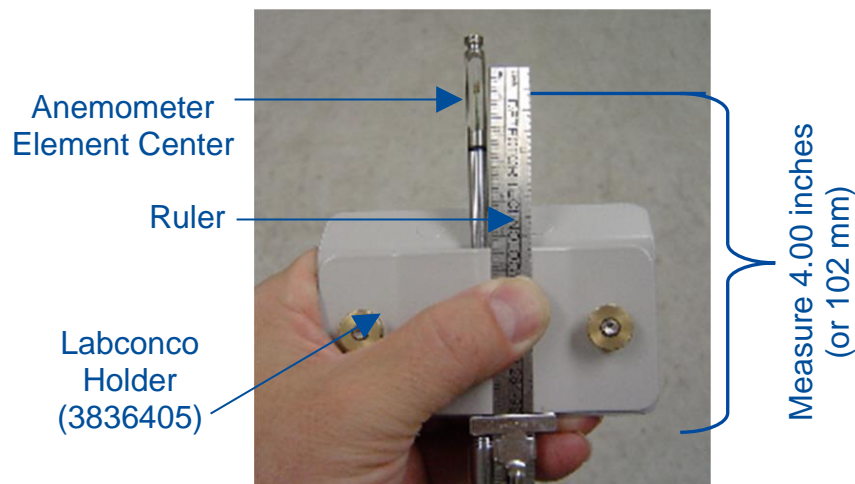
- Thermal Anemometer
- Labconco Certifier Kit (Catalog Number 3858400), which contains:
  - Labconco Holder Bracket Assembly (Part Number 3836405).
  - Left and Right Sash Stops, to position sash at correct restricted height.

**Figure 10-29**

1. Find the set of Sash Stops, which have a '+' engraved under a number. Select the two Sash Stops engraved with a '4 +' as shown in Figure 10-29. The remaining sash stops will not be required for this generation of biosafety cabinet.
2. Place the thermal anemometer probe into the Labconco Holder Bracket Assembly. The thermal anemometer should be positioned such that the distance from the bottom of the Holder Bracket to the center of the anemometer element equals 4.00 inches (102 mm). See Figure 10-30 below. Tighten thumbnuts on Holder to secure probe.

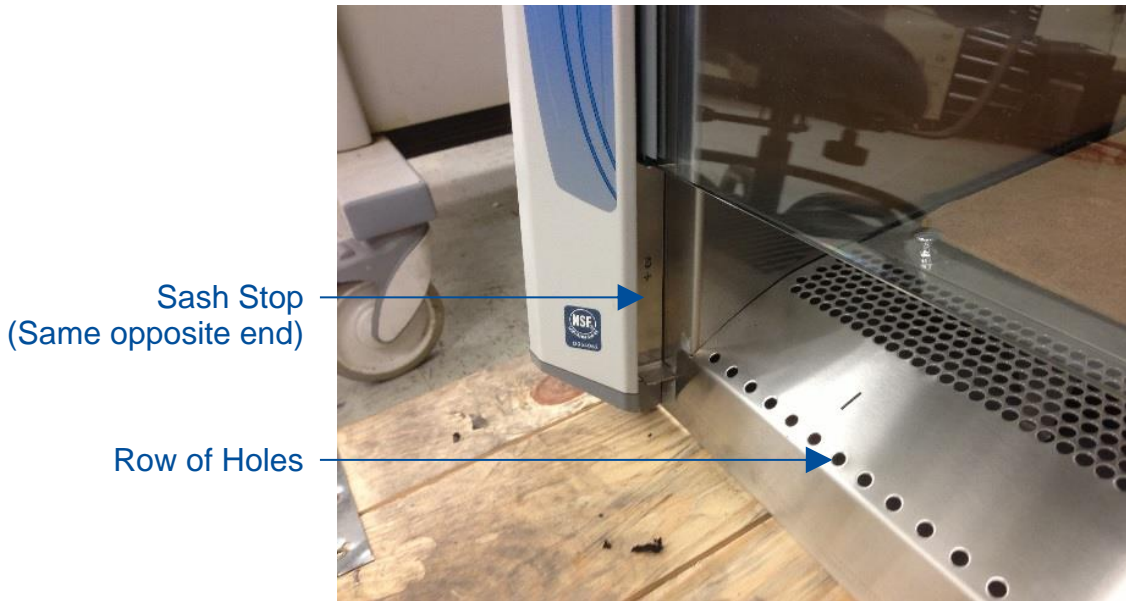


**Figure 10-30**



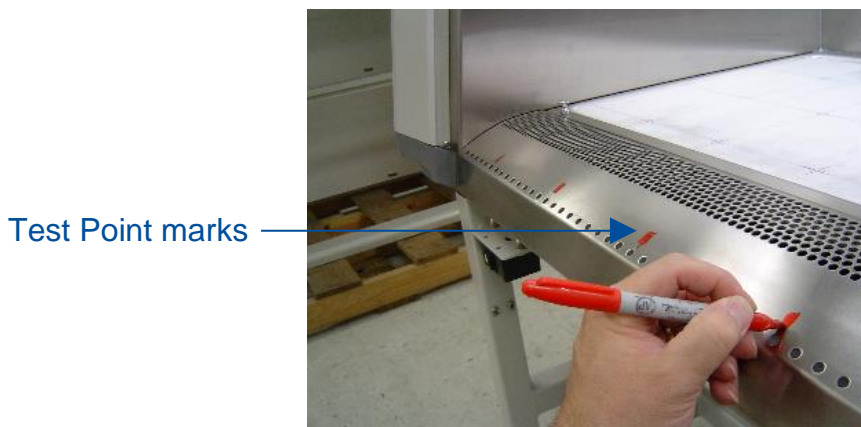
3. Insert the appropriate left and right stop into the recess in each corner post, as shown in Figure 10-31. Lower the sash until it contacts the Sash Stops.

**Figure 10-31**



4. Locate the single row of holes at the front-most edge of the grille, see Figure 10-31.
5. Mark the 6<sup>th</sup> hole from the **left** side wall and subsequently mark every 9<sup>th</sup> hole until the number of test points marked equals the width of the biosafety cabinet in feet. For example, a 5-ft width model should have 5 test points marked.
6. Mark the 6<sup>th</sup> hole from the **right** side wall and subsequently mark every 9<sup>th</sup> hole until the number of test points marked equals the width of the biosafety cabinet in feet. For example, a 5-ft width model should have 5 test points marked. All test points should be marked on the grille. See Figure 10-32 for reference.

**Figure 10-32**



7. Place the thermal anemometer, now secured to the Labconco Holder, onto the grille. The two pins in the Holder will drop into two holes on the grille. The thermal anemometer probe should line up with the test point mark made earlier. Start by placing the anemometer and Holder at the far left test point mark. See Figure 10-33 for reference.

**Figure 10-33**



11. Start the blower(s), and let the cabinet operate for at least 5 minutes. After the 'Wait' period expires and the Blower Status reads 'OK', the biosafety cabinet will display a sash alarm. This is because the sash is at the restricted height required for this test. Press **[OK/MUTE]** to silence the alarm for 5 minutes.
12. This test requires the anemometer to provide highly accurate results. Establish the necessary correction factor to the thermal anemometer from its calibration performance test in a calibrated wind tunnel. This should be available from the calibration institution or company used to calibrate the thermal anemometer. Calculate the thermal anemometer manufacturer's recommended correction factor(s) for conditions of temperature, humidity, barometric pressure, and altitude.
13. Set the anemometer's time constant to 10-15 seconds for greater data stability.
14. Take one velocity reading at each of the marked test points.
15. Average all the readings. Apply the wind tunnel correction and local condition corrections factors to the average velocity reading.
16. Multiply the average inflow velocity by the column "Correction Factor" based on Type and model in Table 10-8.

**Table 10-8**

Type A2 Cabinet Width	Sash Height	# of Test Points	Correction Factor	Corrected Inflow Volume Range	
	inches			CFM	m <sup>3</sup> /hr
3-foot	8	6	0.72	203-223	345-379
	9	6	0.72	228-251	387-426
	10	6	0.72	253-278	430-472
	12	6	0.73	304-335	516-569
4-foot	8	8	0.96	269-296	457-503
	9	8	1.00	303-333	515-566
	10	8	1.01	337-371	573-630
	12	8	0.94	404-444	686-754
5-foot	8	10	1.13	336-370	571-629
	9	10	1.14	378-416	642-707
	10	10	1.15	420-462	714-785
	12	10	1.11	505-555	858-943
6-foot	8	12	1.36	403-443	685-753
	9	12	1.36	453-498	770-846
	10	12	1.37	503-553	855-940
	12	12	1.30	604-665	1025-1129
8-foot	8	16	1.81	551-609	936-1035
	10	16	1.91	676-748	1149-1271
Type B2 Cabinet Width	Sash Height	# of Test Points	Correction Factor	Corrected Inflow Volume Range Sash Height	
	inches			CFM	inches
4-foot	8	8	1.04	269-296	457-503
6-foot	8	12	1.45	403-443	685-753

17. Compare the inflow volume in CFM calculated in step #16 with the value in column "Corrected Inflow Volume Range" based on Type and model shown in Table 10-8.
18. If the Inflow Volume is not within the acceptance criteria range, adjust the biosafety cabinet according to *Adjusting Blower Speed* and/or *Adjusting the Internal Damper* found in [Section 9: Calibration](#).

#### Acceptance Criteria

Inflow Volume shall be in the range specified in Table 10-8 column "Corrected Inflow Volume Range".

### Work Area Air Cleanliness Test (optional)

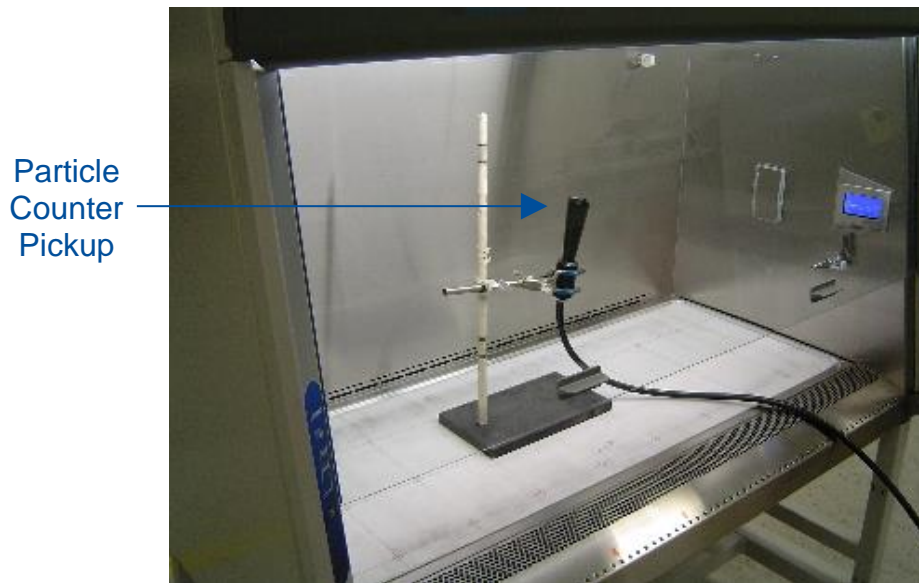
Air cleanliness is a measurement of all particles (greater than or equal to 0.5 micron in size) in the air. This is not an NSF Standard 49 test. However, if the end user would like to verify air cleanliness in the work area, follow these instructions:

1. Mark test points at the geometric center of the work surface(s), and midway between the center test point and each side wall. If testing 8-foot Type A2 models, mark midway between the center test points and the edges each work surface for a total of six (6) test points.
2. Place a particle counter pickup at a height of 16 inches (41 cm) above the work surface, pointing up into the airflow. Place the particle counter pickup at each of the three marked test points, and take one sample at each test point of 1.0 ft<sup>3</sup> of air. See Figure 10-34 for reference.

Note: if sampling 1.0 m<sup>3</sup> instead of 1.0 ft<sup>3</sup>, see Acceptance Criteria below for passing threshold.

3. Average the particle count results from each of the three test points.

**Figure 10-34**



### Acceptance Criteria

The average particle count is less than 100 particles 0.5 micron and larger per cubic foot, or less than 3,520 particles 0.5 micron and larger per cubic meter.

### Lighting Test (optional)

The light intensity should be measured as described in the current NSF/ANSI Standard 49 Annex N. To test the light intensity at the biosafety cabinet's work surface, follow these instructions:



**Note:** A light meter that is color- and cosign-corrected must be used for accurate results.

1. Mark test points on the work surface as follows:
  - a. Mark the front-to-back centerline of the work surface
  - b. Starting 6 inches (15.2 cm) from the left side wall, mark a test point on the front-to-back centerline.
  - c. Continue marking additional test points along the centerline at 12 inch (30.5 cm) increments until the left-to-right center of the work surface is reached.
  - d. Repeat steps b and c starting from the right side wall.
  - e. All test points are now marked.
2. With the biosafety cabinet lights off, take a background reading with the light meter. It should be 15 foot-candles (161 lux) or less.
3. Turn on the lights of the biosafety cabinet. Wait 1 minute.
4. Place the light meter sensor at each of the marked test points and take a reading.
5. Average all test point readings.

### Acceptance Criteria

The average light level shall be no less than 45 foot-candles (484 lux) greater than the background light level reading.

### Noise Test (optional)

The noise (sound pressure) should be measured as described in the current NSF/ANSI Standard 49 Annex N. To test the biosafety cabinet's noise level, follow these instructions:

1. Establish the sound meter location, as follows:
  - a. On the left-to-right centerline of the biosafety cabinet
  - b. 14 inches (35.6 cm) above the work surface
  - c. 12 inches (30.5 cm) from the front of the biosafety cabinet
2. With the biosafety cabinet's blower(s) off, take a background reading with the sound meter. It should be less than 55 dbA.
3. Start the blower(s) and turn on the lights on the biosafety cabinet.
4. Place the sound meter at the location defined in Step 1, take a sound reading.

### Acceptance Criteria

The noise (sound pressure) shall be no more than 70 dbA when the biosafety cabinet is new, and no more than 73 dbA when the filters are loaded with particulate.

### Vibration Test (optional)

The vibration level at the work surface should be measured as described in the current NSF/ANSI Standard 49 Annex N. To test the biosafety cabinet's work surface vibration level, follow these instructions:



**Note:** The vibration meter must have a range of 20-20,000 Hz and provide an output in displacement to proceed with this test.

1. Mark the geometric center of the work surface(s).
2. Place the vibration meter probe at the marked point(s), and with the biosafety cabinet's blower(s) off, take a background reading.
3. Start the biosafety cabinet's blower(s). Wait 1 minute.
4. Take a reading at the same work surface location(s).
5. Subtract the reading with the blower(s) on from the background reading.

### Acceptance Criteria

Net RMS vibration shall be less than 0.0002 inches ( $5 \times 10^{-6}$  m) when the biosafety cabinet is new (at each test point).

## UV Light Intensity Test (optional)

To test the biosafety cabinet's UV light intensity level at the work surface, follow these instructions:



**Note:** The UV radiometer must measure light at a wavelength of 254 nm to proceed with this test.

1. Mark the geometric center of the work surface.
2. Place the radiometer probe at this point, and with the biosafety cabinet's blower(s), light, and UV light off, take a background reading.
3. Close the sash. Turn on the biosafety cabinet's UV Light. Wait 5 minutes.
4. Take a reading at the same work surface location.
5. Subtract the reading with the UV Light on from the background reading.

### Acceptance Criteria

Net UV light intensity shall be at least 100  $\mu\text{W}\cdot\text{cm}^2$  or greater when the biosafety cabinet's UV light lamp is new.

## Ground Fault Circuit Interrupter (GFCI) Test

To test the biosafety cabinet's internal GFCI outlets, follow these instructions:



This test may only be applied on 100-115v models. 208-230v models do not contain GFCI outlets internal to the biosafety cabinet.



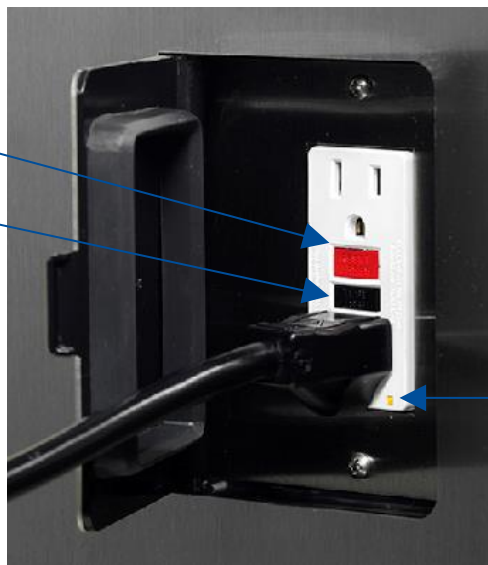
**Note:** The GFCI tester must be capable of simulating a fault of 3mA.

1. Place the tester into any of the biosafety cabinet's outlets. The left side outlet is a standard (non-GFCI) outlet, but it is wired to the LOAD side of the GFCI outlet on the right side wall. It will respond the same; however, to reset power to the outlets after the test, the Reset Button on the right side outlet needs to be pressed.
2. Press the test button on the GFCI tester. The indicator lights on the tester should indicate the outlet is inactive, and the GFCI outlet's power indicator LED should be off. See Figure 10-35 for reference.
3. Reset the GCI by pressing the RESET button on the right side outlet. The tester should indicate power is correctly present at the outlet, and the GFCI outlet's power indicator LED should be on.

**Figure 10-35**

GFCI Reset Button

GFCI Test Button



GFCI Power Indicator LED



The GFCI outlet's RESET and TEST buttons may be white, or red/black (as shown in this figure)

### Acceptance Criteria

The GFCI tester and GFCI outlet in the biosafety cabinet respond as indicated in steps 2 and 3.

## 11: QuickCharts

---

The QuickCharts section provides a central location for all critical data and specifications of all biosafety cabinet types and models. The data included on these charts includes: downflow, inflow, building exhaust system requirements, HEPA filter specifications and leak test parameters.

The charts are provided in imperial (English) units only. Much of the data is located in other areas of this document as they relate to specific calibration and certification procedures and is provided in metric units in those locations. The charts are separated by biosafety cabinet type: A2 and B2.

## QuickChart – Type A2 3-ft & 4-ft

Type A2 Cabinet Width	3-ft				4-ft			
Sash Opening (inches)	8	9	10	12	8	9	10	12
Starting Serial #	2408_	2408_	2408_	2408_	2408_	2408_	2408_	2408_
<b>Downflow Data</b>								
Nominal Avg. Downflow (FPM)	55+/-5	55+/-5	55+/-5	55+/-5	55+/-5	55+/-5	55+/-5	55+/-5
Grid points (rows x columns)	21 (3x7)	21 (3x7)	21 (3x7)	21 (3x7)	24 (3x8)	24 (3x8)	24 (3x8)	24 (3x8)
Grid distance from back & sides	6.0	6.0	6.0	6.0	6.0	6.0	6.0	6.0
Distance between rows	5.80	5.80	5.61	5.44	5.80	5.80	5.61	5.44
Distance between columns	4.08	4.08	4.08	4.08	5.21	5.21	5.21	5.21
<b>Inflow/Exhaust Data</b>								
Nominal Average Inflow (FPM)	105+/-5	105+/-5	105+/-5	105+/-5	105+/-5	105+/-5	105+/-5	105+/-5
Sash Open Area (Sq. Ft)	2.03	2.28	2.53	3.04	2.69	3.03	3.37	4.04
Nominal Avg. Inflow Vol. (CFM)	213	240	266	319	283	318	354	424
Avg. Inflow Vol. Range (CFM)	203-223	228-251	253-278	304-335	269-296	303-333	337-371	404-444
<b>Secondary Inflow Data</b>								
Sash Opening Template <sup>1</sup>	4+	4+	4+	4+	4+	4+	4+	4+
Sensor distance (inches) <sup>2</sup>	4.0	4.0	4.0	4.0	4.0	4.0	4.0	4.0
# of Test points	6	6	6	6	8	8	8	8
Avg. Inflow Vel. Range (FPM)	282-310	317-349	351-386	416-459	280-308	303-333	334-367	430-472
Correction Factor (CF)	0.72	0.72	0.72	0.73	0.96	1	1.01	0.94
Corrected Inflow Volume (CIV) (Avg. velocity x CF)	203-223	228-251	253-278	304-335	269-296	303-333	337-371	404-444
<b>HEPA Filter Leak Test Data</b>								
Air Displacement (CFM)	552	576	600	648	733	765	797	862
Laskin Nozzles needed	2	2	2	2	2	2	2	3
Theoretical aerosol conc. (ug/l) <sup>3</sup>	49	47	45	42	37	35	34	47
<b>Supply HEPA Data</b>								
Labconco P/N	3838410	3838410	3838410	3838410	3838411	3838411	3838411	3838411
Width x Depth x Height (in.) <sup>4</sup>	36x18x3.06	36x18x3.06	36x18x3.06	36x18x3.06	48x18x3.06	48x18x3.06	48x18x3.06	48x18x3.06
Performance (CFM)	335	335	335	335	445	445	445	445
Pressure Drop (in. H <sub>2</sub> O)	.62+/- .1"	.62+/- .1"	.62+/- .1"	.62+/- .1"	.5+/- .1"	.5+/- .1"	.5+/- .1"	.5+/- .1"
<b>Exhaust HEPA Data</b>								
Labconco P/N	3838505	3838505	3838505	3838505	3838501	3838501	3838501	3838501
Width x Depth x Height (in.) <sup>4</sup>	16x18x5.88	16x18x5.88	16x18x5.88	16x18x5.88	26x18x5.88	26x18x5.88	26x18x5.88	26x18x5.88
Performance (CFM)	266	266	266	266	354	354	354	354
Performance (in. H <sub>2</sub> O)	.25-.35"	.25-.35"	.25-.35"	.25-.35"	.2-.37"	.2-.37"	.2-.37"	.2-.37"
<b>LED Lamp Data (2 each)<sup>5</sup></b>								
Labconco P/N	1297503	1297503	1297503	1297503	1297504	1297504	1297504	1297504
LED Lamps (Direct Drive)	12T8-36	12T8-36	12T8-36	12T8-36	15T8-48	15T8-48	15T8-48	15T8-48
Color (°K)	4000	4000	4000	4000	4000	4000	4000	4000
Lumens	1200	1200	1200	1200	1850	1850	1850	1850
Glass Type	Frosted	Frosted	Frosted	Frosted	Frosted	Frosted	Frosted	Frosted
<b>Ventus II Canopy Data</b>								
Labconco Canopy P/N	3889210	3889210	3889210	3889210	3889211	3889211	3889211	3889211
Canopy Slot Area (ft <sup>2</sup> )	.24	.24	.24	.24	.24	.24	.24	.24
Nominal Canopy Inflow (CFM)	37	28	24	26	67	67	66	66
Nominal Canopy Slot Velocity (FPM) <sup>6</sup>	219	213	206	200	225	221	217	213
Canopy Vacuum (in. H <sub>2</sub> O) <sup>7</sup>	0.03	0.04	0.04	0.04	0.09	0.10	0.12	0.15
DIM Total Exhaust Volume Cabinet + Canopy (CFM) <sup>8</sup>	250	268	290	345	350	385	420	490
Traverse Total Exhaust Volume Cabinet + Canopy (CFM) <sup>9</sup>	275	295	319	380	385	424	462	539
<b>Volume of Hull</b>								
Cubic Feet	29	29	29	29	39	39	39	39

## QuickChart – Type A2 5-ft & 6-ft

Type A2 Cabinet Width	5-ft				6-ft			
Sash Opening (inches)	8	9	10	12	8	9	10	12
Starting Serial #	2408_	2408_	2408_	2408_	2408_	2408_	2408_	2408_
<b>Downflow Data</b>								
Nominal Avg. Downflow (FPM)	55+/-5	55+/-5	55+/-5	55+/-5	55+/-5	55+/-5	55+/-5	50+/-5
Grid points (rows x columns)	30(3x10)	30(3x10)	30(3x10)	30(3x10)	36(3x12)	36(3x12)	36(3x12)	36(3x12)
Grid distance from back & sides	6.0	6.0	6.0	6.0	6.0	6.0	6.0	6.0
Distance between rows	5.80	5.80	5.61	5.44	5.80	5.80	5.61	5.44
Distance between columns	5.39	5.39	5.39	5.39	5.50	5.50	5.50	5.50
<b>Inflow/Exhaust Data</b>								
Nominal Average Inflow (FPM)	105+/-5	105+/-5	105+/-5	105+/-5	105+/-5	105+/-5	105+/-5	105+/-5
Sash Open Area (Sq. Ft)	3.36	3.78	4.20	5.05	4.03	4.53	5.03	6.06
Nominal Avg. Inflow Vol. (CFM)	353	397	441	529	423	476	529	634
Avg. Inflow Vol. Range (CFM)	336-370	378-416	420-462	504-555	403-443	453-498	503-553	604-665
<b>Secondary Inflow Data</b>								
Sash Opening Template <sup>1</sup>	4+	4+	4+	4+	4+	4+	4+	4+
Sensor distance (inches) <sup>2</sup>	4.0	4.0	4.0	4.0	4.0	4.0	4.0	4.0
# of Test points	10	10	10	10	12	12	12	12
Avg. Inflow Vel. Range (FPM)	297-327	332-362	365-402	455-500	296-326	333-366	367-404	466-512
Correction Factor (CF)	1.13	1.14	1.15	1.11	1.36	1.36	1.37	1.30
Corrected Inflow Volume (CIV) (Avg. velocity x CF)	336-370	378-416	420-462	504-555	403-443	453-498	503-553	604-665
<b>HEPA Filter Leak Test Data</b>								
Air Displacement (CFM)	915	954	994	1075	1096	1144	1191	1228
Laskin Nozzles needed	3	3	3	3	3	3	3	3
Theoretical aerosol conc. (ug/l) <sup>3</sup>	44	42	41	38	37	35	34	33
<b>Supply HEPA Data</b>								
Labconco P/N	3838412	3838412	3838412	3838412	3838413	3838413	3838413	3838413
Width x Depth x Height (in.) <sup>4</sup>	60x18x3.06	60x18x3.06	60x18x3.06	60x18x3.06	72x18x3.06	72x18x3.06	72x18x3.06	72x18x3.06
Performance (CFM)	555	555	555	555	665	665	665	665
Pressure Drop (in. H <sub>2</sub> O)	.5+/- .1"	.5+/- .1"	.5+/- .1"	.5+/- .1"	.38-.5"	.38-.5"	.38-.5"	.38-.5"
<b>Exhaust HEPA Data</b>								
Labconco P/N	3838502	3838502	3838502	3838502	3838503	3838503	3838503	3838503
Width x Depth x Height (in.) <sup>4</sup>	36x18x5.88	36x18x5.88	36x18x5.88	36x18x5.88	48x18x5.88	48x18x5.88	48x18x5.88	48x18x5.88
Performance (CFM)	441	441	441	441	529	529	529	529
Performance (in. H <sub>2</sub> O)	.2-.37"	.2-.37"	.2-.37"	.2-.37"	.2-.37"	.2-.37"	.2-.37"	.2-.37"
<b>LED Lamp Data (2 each)<sup>5</sup></b>								
Labconco P/N	1297505	1297505	1297505	1297505	1297506	1297506	1297506	1297506
LED Lamps (Direct Drive)	24T8-60	24T8-60	24T8-60	24T8-60	32T8-72	32T8-72	32T8-72	32T8-72
Color (°K)	4000	4000	4000	4000	4000	4000	4000	4000
Lumens	2400	2400	2400	2400	3200	3200	3200	3200
Glass Type	Frosted	Frosted	Frosted	Frosted	Frosted	Frosted	Frosted	Frosted
<b>Ventus II canopy Data</b>								
Labconco Canopy P/N	3889212	3889212	3889212	3889212	3889213	3889213	3889213	3889213
Canopy Slot Area (ft <sup>2</sup> )	.24	.24	.24	.24	.24	.24	.24	.24
Nominal Canopy Inflow (CFM)	77	81	84	110	147	159	171	194
Nominal Canopy Slot Velocity (FPM) <sup>6</sup>	232	238	244	250	216	223	230	237
Canopy Vacuum (in. H <sub>2</sub> O) <sup>7</sup>	0.13	0.16	.018	0.24	0.20	0.23	0.27	0.38
DIM Total Exhaust Volume Cabinet + Canopy (CFM) <sup>8</sup>	430	478	525	640	570	635	700	830
Traverse Total Exhaust Volume Cabinet + Canopy (CFM) <sup>9</sup>	473	525	578	704	627	699	770	913
<b>Volume of Hull</b>								
Cubic Feet	49	49	49	49	58	58	58	58

See footnotes on following page.

## QuickChart – Type A2 8-ft

Type A2 Cabinet Width		8-ft	
Sash Opening (inches)		8	10
Starting Serial #		2507_	2507_
<b>Downflow Data</b>			
Nominal Avg. Downflow (FPM)		55+/-5	55+/-5
Grid points (rows x columns)		48(3x10)	48(3x10)
Grid distance from back & sides		6.0	6.0
Distance between rows		5.80	5.61
Distance between columns		5.21	5.21
<b>Inflow/Exhaust Data</b>			
Nominal Average Inflow (FPM)		105+/-5	105+/-5
Sash Open Area (Sq. Ft)		5.48	6.85
Nominal Avg. Inflow Vol. (CFM)		575	719
Avg. Inflow Vol. Range (CFM)		548-603	685-753
<b>Secondary Inflow Data</b>			
Sash Opening Template <sup>1</sup>		4+	4+
Sensor distance (inches) <sup>2</sup>		4.0	4.0
# of Test points		16	16
Avg. Inflow Vel. Range (FPM)		304-336	354-391
Correction Factor (CF)		1.81	1.91
Corrected Inflow Volume (CIV) (Avg. velocity x CF)		551-609	676-748
<b>HEPA Filter Leak Test Data</b>			
Air Displacement (CFM)		746	810
Laskin Nozzles needed		2	2
Theoretical aerosol conc. (ug/l) <sup>3</sup>		36	33
<b>Supply HEPA Data (2 each)</b>			
Labconco P/N		3838411	3838411
Width x Depth x Height (in.) <sup>4</sup>		48x18x3.06	48x18x3.06
Performance (CFM)		445	445
Pressure Drop (in. H <sub>2</sub> O)		.5+/- .1"	.5+/- .1"
<b>Exhaust HEPA Data (2 each)</b>			
Labconco P/N		3838501	3838501
Width x Depth x Height (in.) <sup>4</sup>		26x18x5.88	26x18x5.88
Performance (CFM)		354	354
Performance (in. H <sub>2</sub> O)		.2-.37"	.2-.37"
<b>LED Lamp Data (4 each)<sup>5</sup></b>			
Labconco P/N		1297504	1297504
LED Lamps (Direct Drive)		15T8-48	15T8-48
Color (°K)		4000	4000
Lumens		1850	1850
Glass Type		Frosted	Frosted
<b>Ventus II canopy Data</b>			
Labconco Canopy P/N		3889214	3889214
Per Exhaust Canopy	Canopy Slot Area (ft <sup>2</sup> )	.24	.24
	Nominal Canopy Inflow (CFM)	58	71
	Canopy Vacuum (in. H <sub>2</sub> O) <sup>7</sup>	0.08	0.11
	DIM Total Exhaust Volume Cabinet + Canopy (CFM) <sup>8</sup>	345	430
	Traverse Total Exhaust Volume Cabinet + Canopy (CFM) <sup>9</sup>	378	473
<b>Volume of Hull</b>			
Cubic Feet		92	92

See footnotes on following page.

## Type A2 Footnotes

### Type and Model Identification

- ✓ The primary serial tag is on the lower right edge of the front Dress Panel.
- ✓ The secondary serial tag is on the rear face of the electronics module on the cabinet's top right side.
- ✓ The first two digits of the serial number are the year of production; the next two are the month. The next 5 digits are the sequence of production, and the letter following the serial number is the revision level of the cabinet.
- ✓ See [Section 3: Catalog Number Configurator](#) to discern Type, Model, and Sash Height from Catalog Number found on the serial tag.

### Downflow Test Specifications

- ✓ All models are classified as uniform downflow.
- ✓ All tests performed as described in the current NSF/ANSI Standard 49.
- ✓ UV Lamp, IV bar and all other accessories must be removed before measuring downflow.

### Inflow Test Specifications

- ✓ All tests performed as described in the current NSF/ANSI Standard 49.

### Secondary Inflow Test Specifications

- ✓ Must use Labconco holder P/N 3836405 to perform this test properly.
- 1. Use the 4+ template included in Certifier Kit P/N 3858400.
- 2. Measured from bottom edge of the probe holder to center of the thermal anemometer element.
- ✓ Locate the single row of holes at the front of the grille. Mark the 6<sup>th</sup> hole from the side wall and subsequent test points every 9 holes until the number of test points marked equals the width of the cabinet in feet (i.e. 3-foot cabinet, mark the first 3 points). Repeat for the opposite side.

### HEPA Filter Leak Test Specifications

- 3. Based on mineral oil.
- ✓ Aerosol generator should be placed in the left rear corner of the work area, pointing at the rear grille for 3-ft, 4-ft, 5-ft, & 6-ft models. For 8-ft models, Aerosol generator should be placed in each rear corner of the work area, pointing at the rear grille, depending on what side of the cabinet's filter set is being scanned.
- ✓ For uncontaminated units, the upstream concentration can be sampled from the tube located under the work surface.

### Supply and Exhaust HEPA Filter Specifications

- 4. Without gasket

### Motor / Blower Specifications

- ✓ Each motor must be programmed by Labconco for the appropriate width cabinet. The PWM setting will fluctuate depending on local temperature and pressure.

### LED Lamp Specifications

- 5. THIS PRODUCT USES DIRECT DRIVE T8 LED LAMPS INSTEAD OF FLUORESCENT LAMPS. THERE IS NO BALLAST; LINE VOLTAGE IS SUPPLIED TO THE LAMP SOCKETS. DO NOT INSTALL FLUORESCENT LAMPS! FOR REPLACEMENT LED LAMPS, CONTACT LABCONCO PRODUCT SERVICE DEPARTMENT.

### Canopy & Remote Exhaust System Data

- 6. Average face velocity at Canopy Slot as established by NSF during listing testing.
- 7. Measured in the center of the duct diameter, halfway up the BSC Duct Stub, relative to atmosphere. Reference Figure 7-5 in [Section 7: Exhaust System Connections](#).
- 8. DIM = Direct Inflow Meter
- 9. Measured in the exhaust duct via traverse methodology and will always be higher due to differences in volume measurement methodologies.

### UV lamp Specifications

- ✓ For all models, the UV lamp model is G30T8. Labconco P/N 1271300.
- ✓ For all 115/230 VAC models, the ballast assembly is Labconco P/N 1295510.

## QuickChart – Type B2

Type B2 Cabinet Width	4-ft	6-ft
Sash Opening (inches)	8	8
Starting Serial #	2408_	2408_
<b>Downflow Data</b>		
Nominal Avg. Downflow (FPM)	55+/-5	55+/-5
Grid points (rows x columns)	24 (3x8)	36(3x12)
Grid distance from back & sides	6.0	6.0
Distance between rows	5.80	5.80
Distance between columns	5.21	5.50
<b>Inflow/Exhaust Data</b>		
Nominal Average Inflow (FPM)	105+/-5	105+/-5
Sash Open Area (Sq. Ft)	2.69	4.03
Nominal Avg. Inflow Vol. (CFM)	283	423
Avg. Inflow Vol. Range (CFM)	269-296	403-443
<b>Secondary Inflow Data</b>		
Sash Opening Template <sup>1</sup>	4+	4+
Sensor distance (inches) <sup>2</sup>	4.0	4.0
# of Test points	8	12
Avg. Inflow Vel. Range (FPM)	259-285	278-306
Correction Factor (CF)	1.04	1.45
Corrected Inflow Volume (CIV) (Avg. velocity x CF)	269-296	403-443
<b>Supply HEPA Filter Leak Test Data</b>		
Air Displacement (CFM)	450	612
Laskin Nozzles needed	1	1
Theoretical aerosol conc. (ug/l) <sup>3</sup>	30	22
<b>Supply HEPA Data</b>		
Labconco P/N	3838411	3838413
Width x Depth x Height (in.) <sup>4</sup>	48x18x3.06	72x18x3.06
Performance (CFM)	445	665
Pressure Drop (in. H <sub>2</sub> O)	.5+/- .1"	.38- .5"
<b>Exhaust HEPA Filter Leak Test Data</b>		
Air Displacement (CFM)	695	1175
Laskin Nozzles needed	2	2
Theoretical aerosol conc. (ug/l) <sup>3</sup>	39	23
<b>Exhaust HEPA Data</b>		
Labconco P/N	3438501	3438503
Width x Depth x Height (in.) <sup>4</sup>	26x18x8.08	48x18x8.08
Performance (CFM)	720	1100
Performance (in. H <sub>2</sub> O)	.48+/- .07"	.37+/- .07"
<b>LED Lamp Data (2 each)<sup>5</sup></b>		
Labconco P/N	1297504	1297506
LED Lamps (Direct Drive)	15T8-48	32T8-72
Color (°K)	4000	4000
Lumens	1850	3200
Glass Type	Frosted	Frosted
<b>Remote Exhaust System Data</b>		
DIM <sup>6</sup> Total Exhaust Airflow (CFM) <sup>7</sup>	695	1175
Traverse Total Exhaust Airflow (CFM) <sup>8</sup>	818	1382
Recommended Duct Vacuum (in. H <sub>2</sub> O) <sup>9</sup>	1.8	2.5
<b>Exhaust (Inflow) Alarm Data</b>		
Inflow Alarm Set Point (CFM) <sup>10</sup>	136 +/-5	216 +/-5
<b>Volume of Hull</b>		
Cubic Feet	39	58

See footnotes on following page.

## Type B2 Footnotes

### Type and Model Identification

- ✓ The primary serial tag is on the lower right edge of the front Dress Panel.
- ✓ The secondary serial tag is on the rear face of the electronics module on the cabinet's top right side.
- ✓ The first two digits of the serial number are the year of production; the next two are the month. The next 5 digits are the sequence of production, and the letter following the serial number is the revision level of the cabinet.
- ✓ See [Section 3: Catalog Number Configurator](#) to discern Type, Model, and Sash Height from Catalog Number found on the serial tag.

### Downflow Test Specifications

- ✓ All models are classified as uniform downflow.
- ✓ All tests performed as described in the current NSF/ANSI Standard 49.
- ✓ UV Lamp, IV bar and all other accessories must be removed before measuring downflow.

### Inflow Test Specifications

- ✓ All tests performed as described in the current NSF/ANSI Standard 49.

### Secondary Inflow Test Specifications

- ✓ Must use Labconco holder P/N 3836405 to perform this test properly.
- 1. Use the 4+ template included in Certifier Kit P/N 3858400.
- 2. Measured from bottom edge of the probe holder to center of the thermal anemometer element.
- ✓ Locate the single row of holes at the front of the grille. Mark the 6<sup>th</sup> hole from the side wall and subsequent test points every 9 holes until the number of test points marked equals the width of the cabinet in feet (i.e. 4-foot cabinet, mark the first 4 points). Repeat for the opposite side.

### HEPA Filter Leak Test Specifications

- 3. Based on mineral oil.
- ✓ Aerosol generator should be placed in the left rear corner of the work area, pointing at the rear grille.
- ✓ For uncontaminated units, the upstream concentration for the Supply HEPA only can be sampled from the tube located under the work surface.

### Supply and Exhaust HEPA Filter Specifications

- 4. Without gasket

### Motor / Blower Specifications

- ✓ Each motor must be programmed by Labconco for the appropriate width cabinet. The PWM setting will fluctuate depending on local temperature and pressure.

### LED Lamp Specifications

- 5. THIS PRODUCT USES DIRECT DRIVE T8 LED LAMPS INSTEAD OF FLUORESCENT LAMPS. THERE IS NO BALLAST; LINE VOLTAGE IS SUPPLIED TO THE LAMP SOCKETS. DO NOT INSTALL FLUORESCENT LAMPS! FOR REPLACEMENT LED LAMPS, CONTACT LABCONCO PRODUCT SERVICE DEPARTMENT.

### Remote Exhaust System Data

- 6. DIM = Direct Inflow Meter
- 7. Total Exhaust Volume required from remote (building) exhaust system.
- 8. Measured as per ASHRAE methodology for measuring air volume in round ducts. These values are approximations, as the calculated traverse volume value may vary depending on sampling location, exhaust system, and methodology.
- 9. Measured at the exhaust transition sampling point, relative to atmosphere.

### Exhaust (Inflow) Alarm Data

- 10. Alarm set point is 80% of the total volume of air drawn by the remote exhaust system. See Table 9-1 in [Section 9: Airflow Calibration](#).

### UV lamp Specifications

- ✓ For all models, the UV lamp model is G30T8. Labconco P/N 1271300.
- ✓ For all 115/230 VAC models, the ballast assembly is Labconco P/N 1295510.

## 12: Advanced Service Procedures

---

This section provides instructions to perform advanced service procedures on the biosafety cabinet. Such procedures include changing HEPA filters, adjusting the sash or sash position sensors, replacing LED or UV lamps, and more.



### Tools

#### Required

- #2 Phillips screwdriver or #2 Phillips bit (4 inches long minimum)
- Ratchet with extension
- Sockets
  - 5/16-inch
  - 3/8-inch
  - 7/16-inch
  - 1/2-inch
- 3/8-inch nut driver
- 1/2-inch nut driver

#### Optional

- Cordless screwdriver/drill
- Cordless ratchet (low profile right angle impact driver)
- Pliers (standard and needle nose)
- #10-24 Tap
- 5/16-18 Tap



If a cordless screwdriver or drill is used to drive screws, reduce the torque setting to a minimum to avoid stripping the screw head.

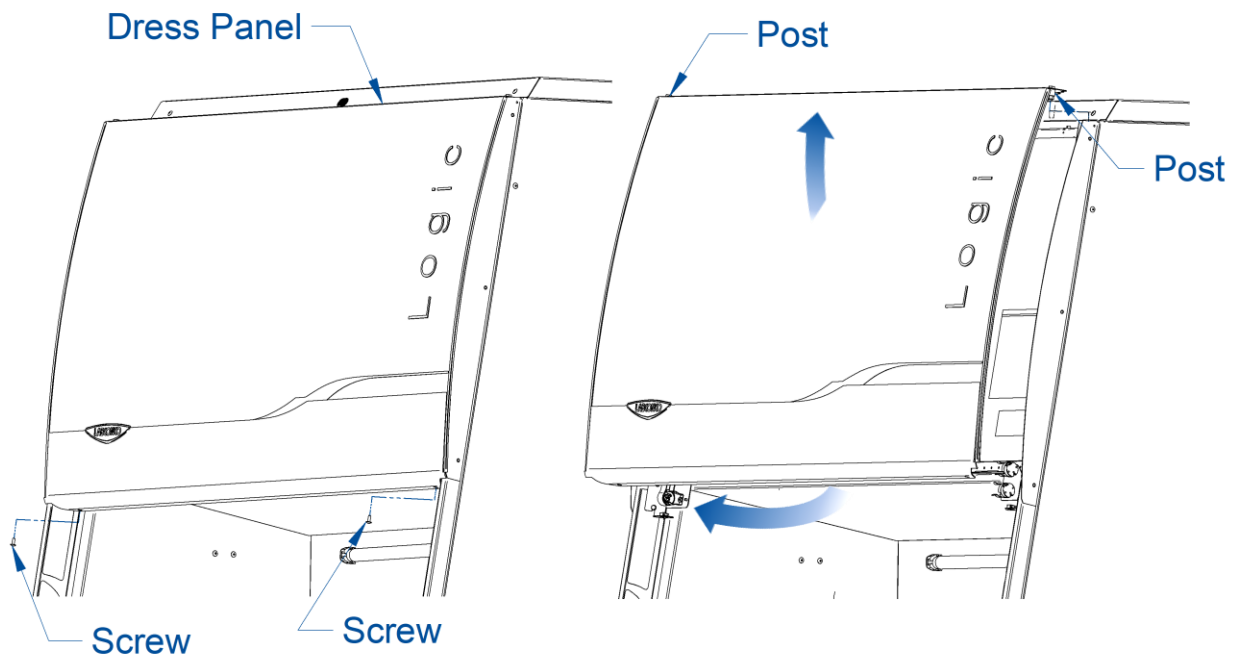
## Removal of External Dress Panels

To access the HEPA filters, LED lamps, sash sensors, the touch-screen display, and other service areas, the front panel and Side Panels will be removed. This section describes removal of the external Dress Panels.

### Dress Panel

1. Locate and remove the two Phillips screws that secure the front Dress Panel as shown in Figure 12-1.

Figure 12-1



2. Swing the bottom edge of the Dress Panel out (away from biosafety cabinet) to clear the LED lamps underneath. Then lift the entire Dress Panel up to clear the two white posts on the top right and left corners of the Dress Panel. The two posts protrude down from the top flange of the Dress Panel.



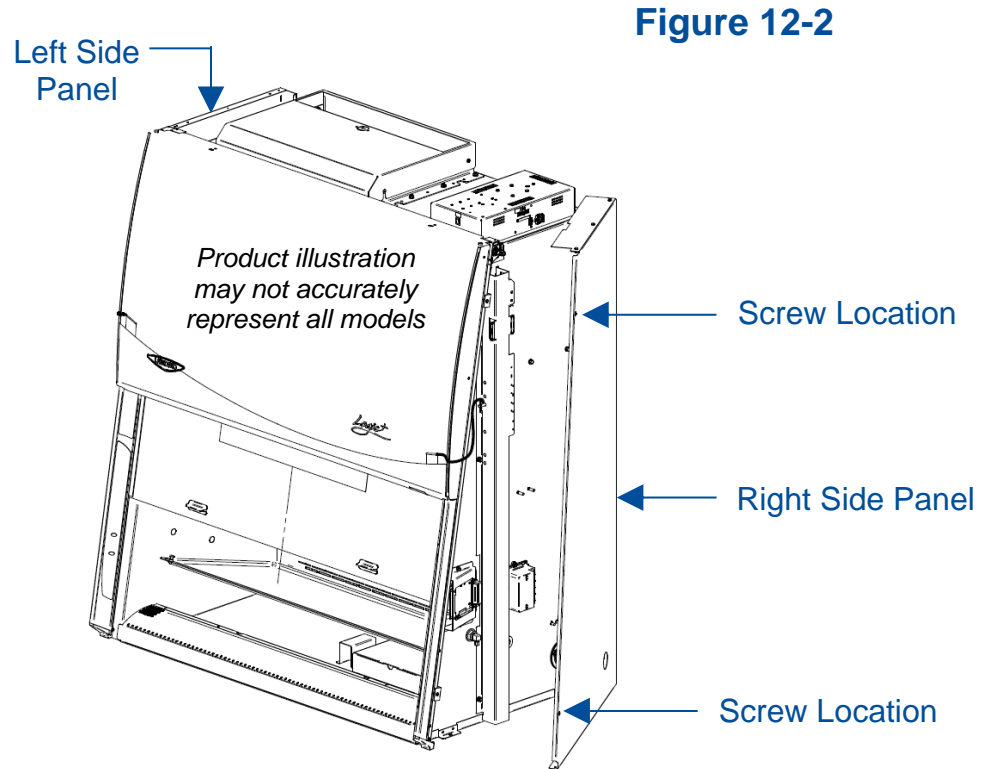
The Dress Panel is heavy, and awkward to maneuver, use two persons to lift the Dress Panel.

### Reinstallation Notes:

1. Make sure the two white posts are fully engaged into the top of each corner post before replacing the two screws at the bottom corners of the Dress Panel.

## Side Panels

1. Locate and remove the two Phillips screws along the front edge of each Side Panel.



2. The Side Panels will hinge open once the screws are removed.
3. If Side Panel needs to be removed, position the panel so that it is almost closed. Grasp the panel by the front and rear edges. Lift the panel up approximately 2 inches (5 cm), then pull it straight away from the end of the biosafety cabinet.

### Exhaust Cover (A2 Only)



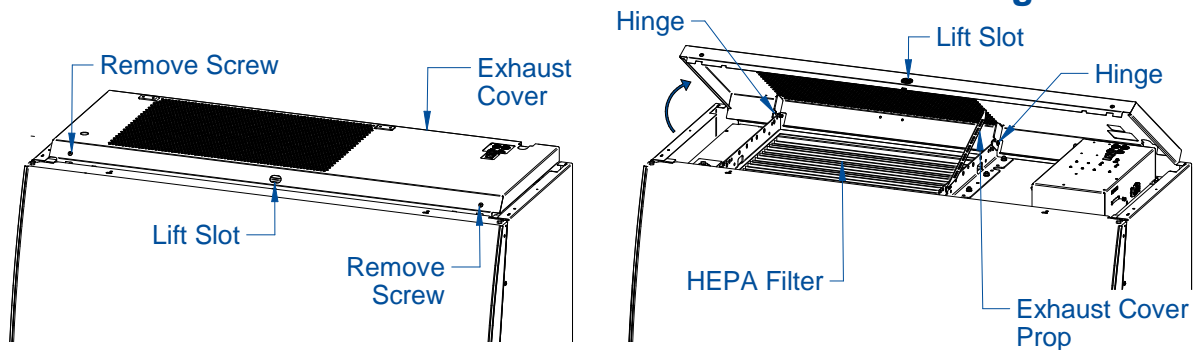
It is recommended to utilize at least two (2) persons to remove the exhaust cover, particularly for a 5-ft or 6-ft model. The exhaust cover is heavy. Take care to use safe lifting practices, and to set the panel where it cannot fall over while uninstalled from the cabinet.



**Note:** All 8-foot Type A2 Models have two (2) exhaust covers. For the 8-foot only, follow the entire instructions below on one side, before repeating all steps again on the remaining side.

1. Remove and save the two (2) phillips screws in the front of the cover(s). Reference Figure 12-3.
2. Hinge the cover(s) up from the front using the lift slot.
3. If full removal is not needed, Skip to step 5. To remove the exhaust cover(s), pull the slightly lifted exhaust cover(s) forward, until the hinges (reference Figure 12-3) of the cover(s) are free from the cabinet.

**Figure 12-3**



4. Once free, carefully pull away and lower from the cabinet. Store safely.
5. If leaving the cover(s) installed, the exhaust cover(s) can be secured in the lifted position by using the exhaust cover prop. Rotate the prop(s) up and against the exhaust cover(s). Insert the end of the prop(s) into the exhaust cover perforations to keep the cover(s) lifted to height required for servicing. Reference Figure 12-3.
6. Carefully lower the exhaust cover(s) onto the prop(s) and release when stable. Do not release the exhaust cover(s) if the prop is not fully in place against the cover.

### Reinstallation Notes:

1. Make sure the backwards facing slots of the hinge are installed onto the black bushings on the filter brackets.

## Front Sash

The glass sash utilizes a cable and pulley system with counter weights located in the right and left end service compartments. This section describes adjustments or repairs to the sash or sash sensors.

### Sash Level Adjustment

The sash and its two counter weights are joined together with two sash cables, one per counter weight. The sash cables run on pulleys, which are joined together by a common axle. Each pulley is locked to this axle with a cotter pin. This prevents the sash from racking when raised from only one end of the sash glass. The sash should have approximately 1/8 inch (3 mm) of lateral play or movement. Under normal operation, the sash should remain level. Occasionally, during transport of the biosafety cabinet, the sash may become unlevel. Follow the instructions below to resolve this issue.

1. Lower the sash until it is fully closed. Identify which end of the sash is high.
2. Hinge open or remove the Side Panel on the high end of the sash. Side Panel access and removal is described earlier in this section under *Removal of External Dress Panels*.
3. Using pliers, grasp the S-Hook atop the counterweight. Pull up on the counterweight to allow some slack in the sash cable. See Figure 12-4.
4. The high end of the sash should lower against the sash stop, and the sash is now level. Carefully lower the counterweight and sash cable back onto the pulley.

**Figure 12-4**



5. Reinstall and/or close the Side Panel.

## Sash Sensor Adjustment or Replacement

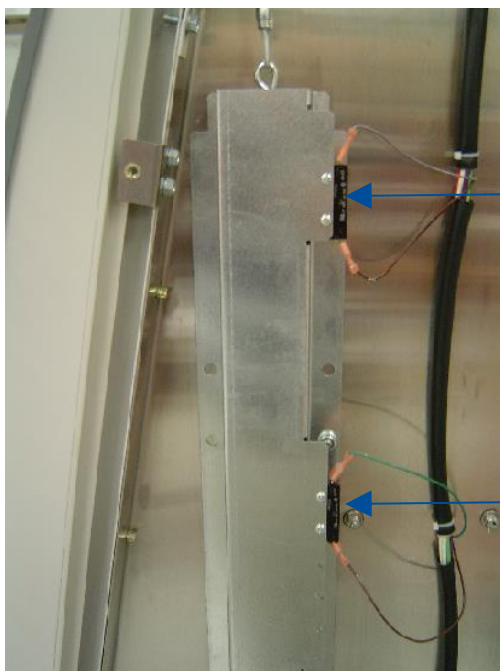
The biosafety cabinet senses the sash's vertical position with mechanical switches located on the counterweight channel in the right end service compartment. The switches activate off of the counterweight as it travels in the channel. These switches are reliable and do not require calibration. Should the biosafety cabinet not respond as expected to the position of the sash (for example, automatic blower/light operation when sash is closed/opened, or a sash alarm when sash not within 1 inch (25 mm) of nominal operating position), examine the sash switches and adjust/replace as necessary.

1. Hinge open or remove the right end Side Panel as described earlier in this section under *Removal of External Dress Panels*.
2. Locate the sash switches on the counterweight channel. Table 12-1 indicates which switches will be present based on the type and sash height. Figure 12-5 identifies the location of these switches.

**Table 12-1**

Type	Nominal Width	Sash Height (inches)	Closed	Almost Closed	Operating Position 1	Operating Position 2
A2	3ft, 4ft, 5ft, 6ft	8, 9, 10, 12	Yes		Yes	
	8ft	8, 10	Yes	Yes	Yes	
B2	ALL	8	Yes		Yes	

**Figure 12-5**



**Top switch location**

CLOSED switch: silver tab UP

ALMOST CLOSED switch (if present): silver tab DOWN

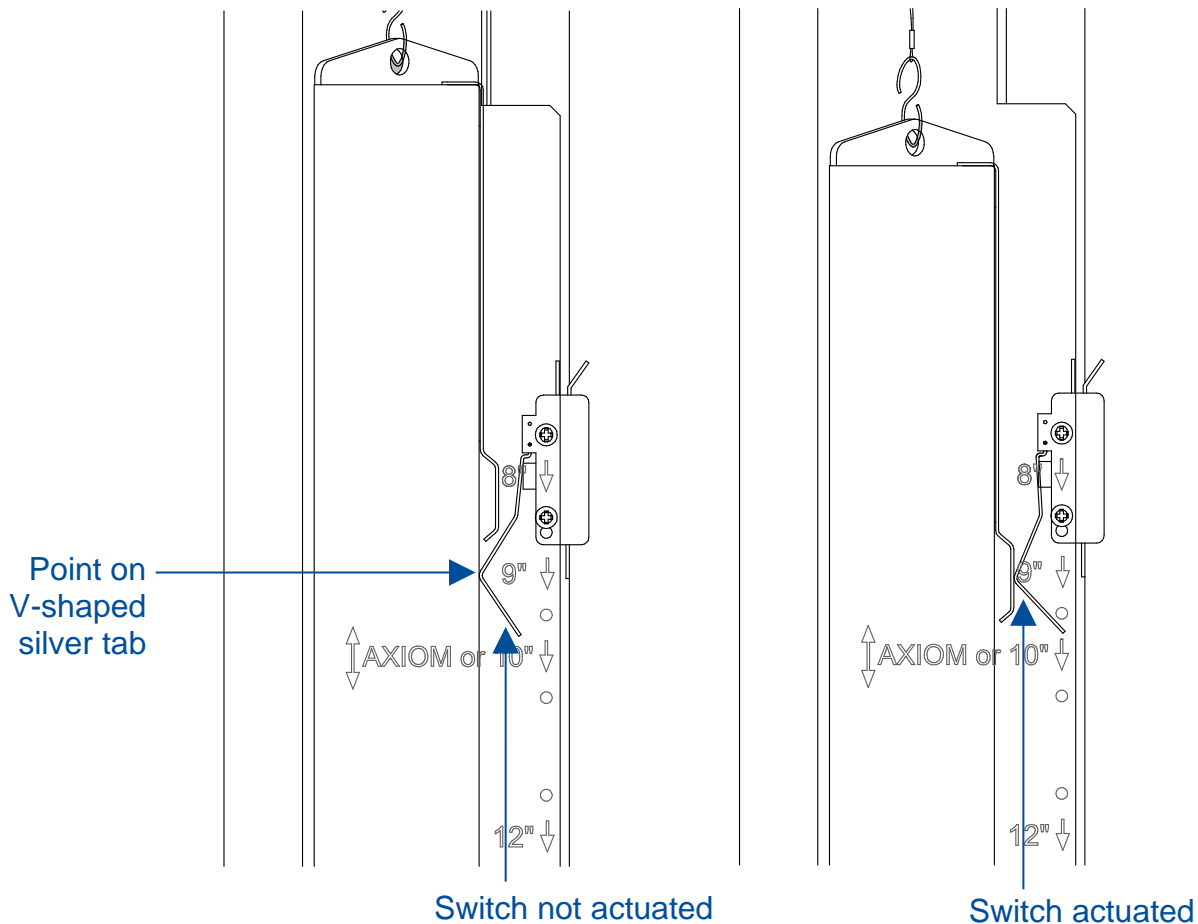
**Bottom switch location**

Operating Pos. 1 switch: silver tab DOWN

Operating Pos. 2 switch (if present): silver tab UP

3. If the blower is on, turn it off, and turn off other noise producing equipment nearby. This step involves listening for a click from each switch. Check each switch function by slowly raising and lowering the sash. Check each switch to see if an audible click is heard when the sash is at key positions:
  - a. **CLOSED** – close (lower) the sash, and within 1 inch (25 mm) of fully closed, an audible click is heard from the **CLOSED** switch shown in Figure 12-5.
  - b. **ALMOST CLOSED** – from the fully closed position, raise the sash slowly until the **CLOSED** switch disengages (first click), and within 2 inches (50 mm) of upward travel a second click should be heard from the **ALMOST CLOSED** switch.
  - c. **OPERATING POSITION 1** – continue raising the sash slowly from closed, and when the bottom edge of the sash glass is within 1 inch (25 mm) of the sash height decal on the left corner post, a click is heard from the **OPERATING POSITION** switch shown in Figure 12-5.

**Figure 12-6**



4. If operation is not as described in Step 3, repeat Step 3, positioning yourself to view the silver, formed tabs on each sash switch. Watch as the counterweight approaches each switch. Here is the expected behavior:
  - a. CLOSED and ALMOST CLOSED (if present) switch – The silver tab should engage and rotate away from the sash counterweight, with the click occurring as soon as the point of the V-shaped silver tab reaches the top of the counterweight. See Figure 12-6 for reference.
  - b. OPERATING POSITION switch – The silver tab should engage and rotate away from the sash counterweight, but the click should occur when the stainless steel “bump” attached to the counterweight reaches the point of the V-shaped silver tab.
5. If a switch is not actuating properly, move the sash so that the counterweight is well below the switch in question. Move the silver tab on the switch with your finger. If an audible click is heard when moving by hand, using pliers CAREFULLY bend the silver tab so that it protrudes further into the counterweight channel. Hold the base of the silver tab with one set of pliers, and form the tab by pushing it with your finger. Prying on the silver tab without supporting the base (where it is hinged on the black switch body), may break the tab off of the switch, in which case the switch is permanently damaged and needs to be replaced.
6. If the switch is defective, replace it by removing the two machine screws and nuts holding the sensor in place. Take care to note the orientation of the switch and wiring before switch removal, so the new switch can be properly re-wired and reassembled.

## HEPA Filter Replacement

The HEPA filters load with particulate as the biosafety cabinet operates. Eventually, the filters will need to be replaced. Only replace a HEPA filter if you are a qualified and trained certifier or technician.



The HEPA filters on a biosafety cabinet will be contaminated with biohazardous material. Always assume the HEPA filter is contaminated, even if you are told the biosafety cabinet has not been used. For your safety, take all necessary precautions before opening the filter cover(s), including: gaseous decontamination of the biosafety cabinet, proper breathing, eye, and skin protection from biohazards.

### Type A2



Follow these instructions carefully, and in the order documented. Always remove the exhaust HEPA filter first. The exhaust filter pan can be damaged if the plenum is raised with the exhaust HEPA filter in place.

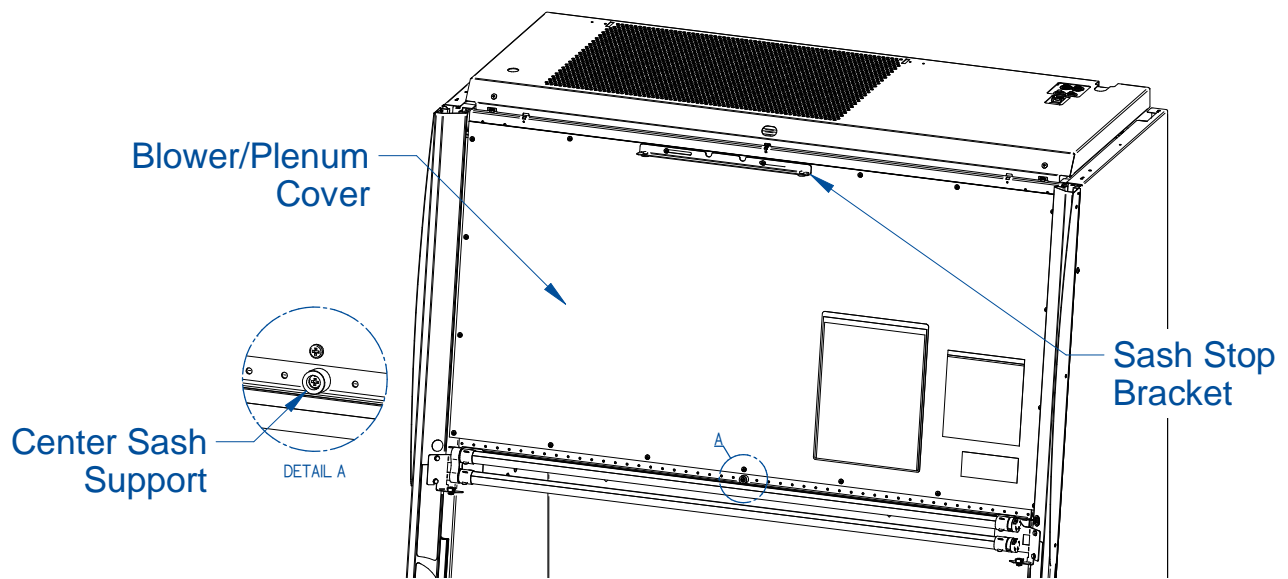


HEPA filters can be awkward to handle, and quite heavy for larger models. Use safe lifting techniques when removing and replacing the filters. Always use two persons to remove and replace each HEPA filter.



1. Thoroughly and properly decontaminate the biosafety cabinet.
2. Remove the front Dress Panel as described earlier in this section under *Removal of External Dress Panels*. Unplug the power cord to this biosafety cabinet.
3. Loosen all of the Phillips screws around the perimeter of the blower/plenum cover. Remove all screws except two along the top edge of the cover. This will support the cover. The sash stop bracket (reference Figure 12-7) is held in place by two of the blower/plenum cover screws. Remove this bracket.

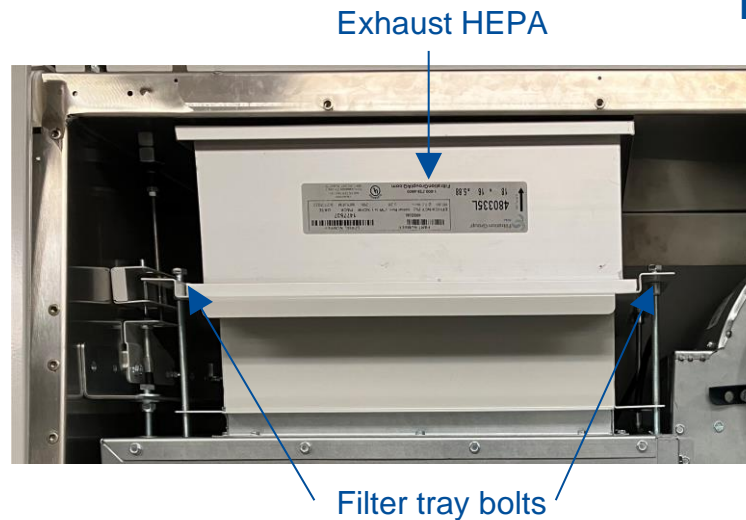
**Figure 12-7**



4. Remove the last two screws. The blower/plenum cover will rest on the center sash support (Figure 12-7) after the final screws are removed. Gently break the gasket seal on the cover by starting in one corner. Use a flat screwdriver if necessary, taking care not to damage the gasket or panel by prying too hard in one area. Once the gasket seal is free, slide the cover to the left or right, and bend it slightly to free one end by getting it past the corner post. Lift the blower/plenum cover off.

- Using a 1/2-inch socket, loosen the 4 bolts at each corner of the exhaust filter tray (Fig. 12-8 shows the front 2), until filter drops 1/2 inch (13 mm).

**Figure 12-8**



- Slide the exhaust HEPA filter straight out of the biosafety cabinet.
- To remove the supply HEPA filter, the exhaust HEPA filter must be removed first. Using a 1/2-inch socket, tighten the 3 plenum lift bolts (turning each bolt clockwise will raise the plenum) until the plenum raises 1/2-inch (13 mm). See Figure 12-9 for reference.

**Figure 12-9**



- Remove the 3 supply HEPA filter retainer brackets (see Figure 12-9).

9. Lift up on one corner of the supply HEPA filter to break the seal between the filter gasket and the filter shelf. Once the filter is free, slide it straight out.

Note: All 8-foot Type A2 models have two (s) sets of HEPA filters.

10. If conducting filter replacement on an 8-foot model, repeat steps 3 through 9 on the other side.

Reinstallation Notes:

1. When reinstalling the supply HEPA filter, to lower the plenum onto the supply HEPA, turn the 3 plenum lift bolts counter-clockwise. Turn each bolt part way, working in a pattern amongst the 3 bolts to lower the plenum evenly.
2. When downward pressure begins to be applied onto the supply HEPA (and upward pressure on the exhaust HEPA when it is reinstalled separately), the brackets holding the bolts you are tightening will flex slightly. Only tighten until the filters are secure and the filter gasket has 50% compression. Do not overtighten the bolts.

### Type B2

Follow these instructions carefully, and in the order documented.



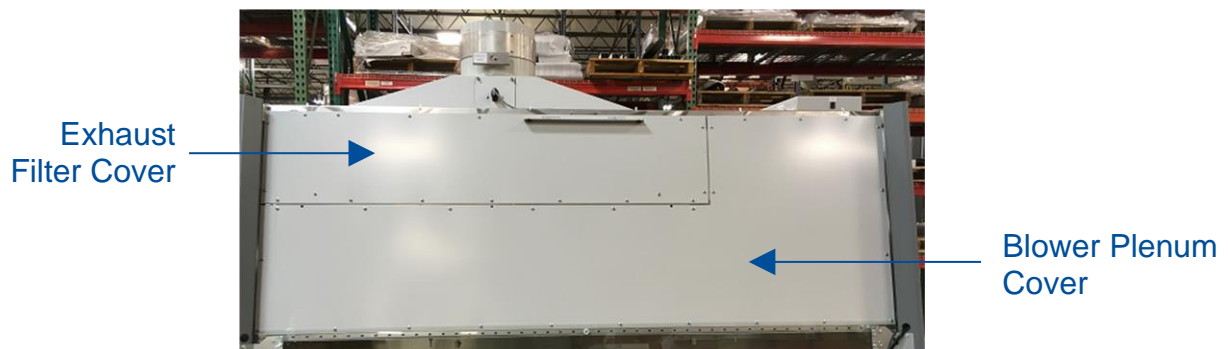
HEPA filters can be awkward to handle, and quite heavy for larger models. Use safe lifting techniques when removing and replacing the filters. Always use two persons to remove and replace each HEPA filter.



1. Thoroughly and properly decontaminate the biosafety cabinet.
2. Remove the front Dress Panel as described earlier in this section under *Removal of External Dress Panels*. Unplug the power cord to this biosafety cabinet.
3. Remove all of the Phillips screws around the perimeter of the exhaust filter cover. Gently break the gasket seal on the cover by starting in one corner. Use a flat screwdriver if necessary, taking care not to damage the gasket or panel by prying too hard in one area. Remove the exhaust filter cover. See Figure 12-10.

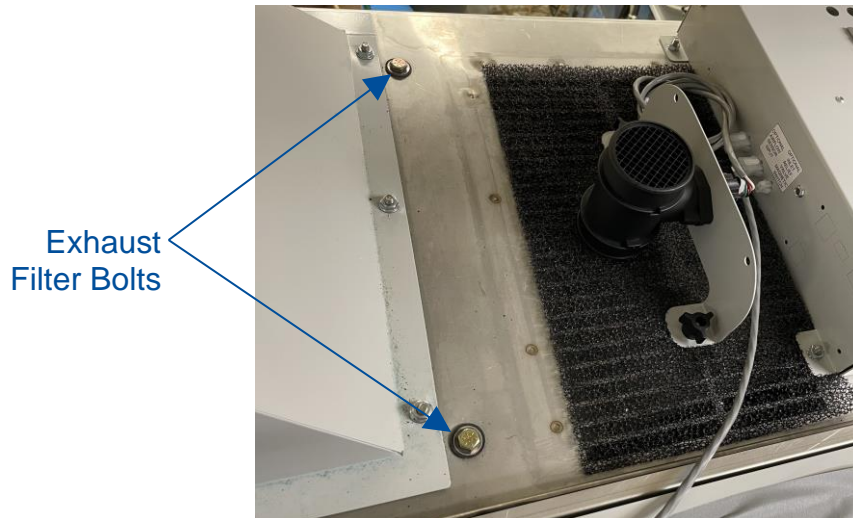


**Figure 12-10**



4. To remove the exhaust HEPA filter, use a 1/2-inch socket to loosen the 4 bolts on top of the cabinet liner (Figure 12-11) until filter drops 1/2 inch to 3/4 inch (19 mm). Do not remove these 4 bolts, just loosen them to lower the exhaust filter.
5. Slide the exhaust HEPA filter straight out of the biosafety cabinet.

**Figure 12-11**



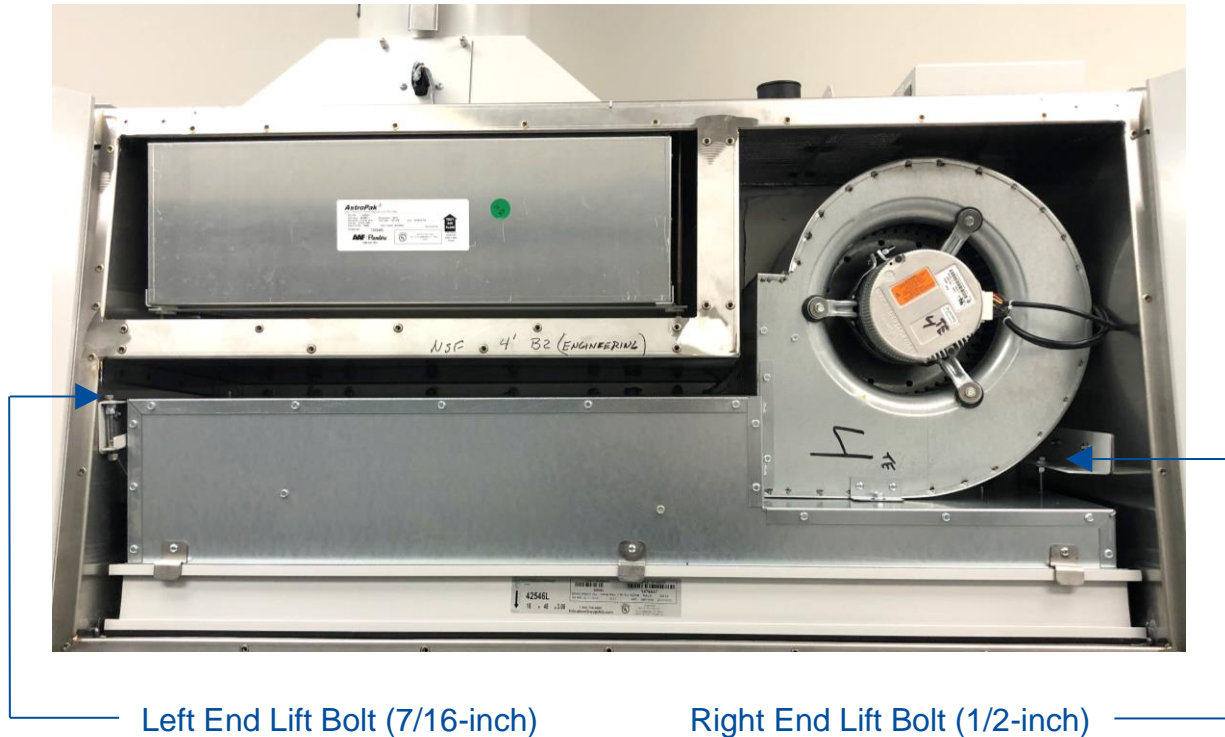
6. To remove the supply HEPA filter, loosen all of the Phillips screws around the perimeter of the blower/plenum cover. Remove all screws except two along the top edge of the cover. This will support the cover. The sash stop bracket is held in place by two of the blower/plenum cover screws. Remove this bracket.
7. Remove the last two screws. The blower/plenum cover will rest on the center sash support (Figure 12-12) after the final screws are removed. Gently break the gasket seal on the cover by starting in one corner. Use a flat screwdriver if necessary, taking care not to damage the gasket or panel by prying too hard in one area. Once the gasket seal is free, slide the cover to the left or right, and bend it slightly to free one end by getting it past the corner post. Lift the blower/plenum cover off.

**Figure 12-12**



- Use a 1/2-inch socket on the right end lift bolt and a 7/16-inch socket on the left end lift bolt, tighten the 2 plenum lift bolts (turning each bolt clockwise will raise the plenum) until the plenum raises 1/2-inch (13 mm). See Figure 12-13 for reference.

**Figure 12-13**



- Remove the 3 supply HEPA filter retainer brackets (see Figure 12-14).

**Figure 12-14**

- Lift up on one corner of the supply HEPA filter to break the seal between the filter gasket and the filter shelf. Once the filter is free, slide it straight out.



**Filter Retainer Bracket**

**Reinstallation Notes:**

- When reinstalling the supply HEPA filter, to lower the plenum onto the supply HEPA, turn the 2 plenum lift bolts counter-clockwise. Turn each bolt part way, working back and forth between the 2 bolts to lower the plenum evenly.
- When downward pressure begins to be applied onto the supply HEPA (and upward pressure on the exhaust HEPA when it is reinstalled separately), the brackets holding the bolts you are tightening will flex slightly. Only tighten until the filters are secure and the filter gasket has 50% compression. Do not overtighten the bolts.

## Blower/Motor Replacement

The motor(s) in the biosafety cabinet are ECM, brushless DC motors with extremely high reliability. It is rare for the motor to fail. If the blower(s) fail to start, check all possible causes first. The most likely cause for blower failure is a loose wire connection. Another reason for accessing the blower/motor is a foreign object caught in the blower wheel, or the blower wheel is out of balance.



The blower/motor assembly on a biosafety cabinet will be contaminated with biohazardous material. Always assume the blower/motor is contaminated, even if you are told the biosafety cabinet has not been used. For your safety, take all necessary precautions before opening the blower/plenum cover, including: gaseous decontamination of the biosafety cabinet, proper breathing, eye, and skin protection from biohazards.

### Type A2 & B2



If replacing a blower/motor assembly, the motor must be programmed at Labconco. The blower/motor assembly must also be balanced by Labconco, and therefore it is strongly recommended to replace the blower/motor assembly, never the motor or blower individually. Failure to replace the blower/motor with a genuine Labconco assembly will result in failed or incorrect operation, which can jeopardize the protection the biosafety cabinet provides the operator, product, and lab environment.

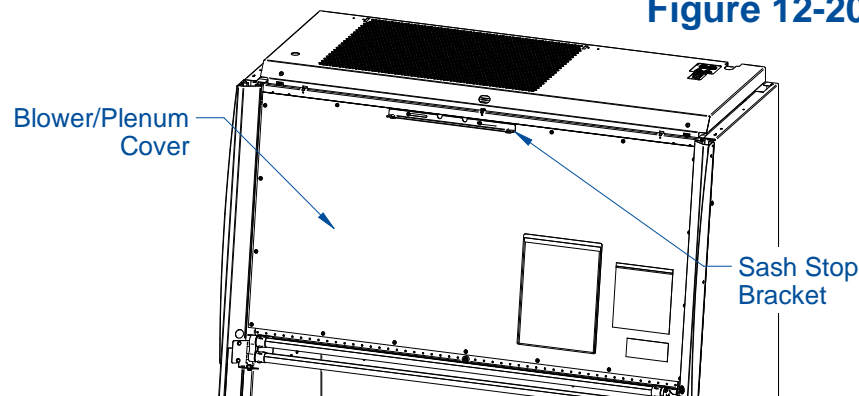


Blower/motors can be awkward to handle, and the blower wheel may contain sharp edges. Use safe lifting techniques when removing and replacing the blower/motor. Always wear gloves and eye protection when handling a blower/motor assembly.

1. Thoroughly and properly decontaminate the biosafety cabinet.
2. Remove the front Dress Panel as described earlier in this section under *Removal of External Dress Panels*. Unplug the power cord to this biosafety cabinet.
3. Loosen all of the Phillips screws around the perimeter of the blower/plenum cover. Remove all screws except two along the top edge of the cover. This will support the cover. The sash stop bracket is held in place by two of the blower/plenum cover screws. Remove this bracket.

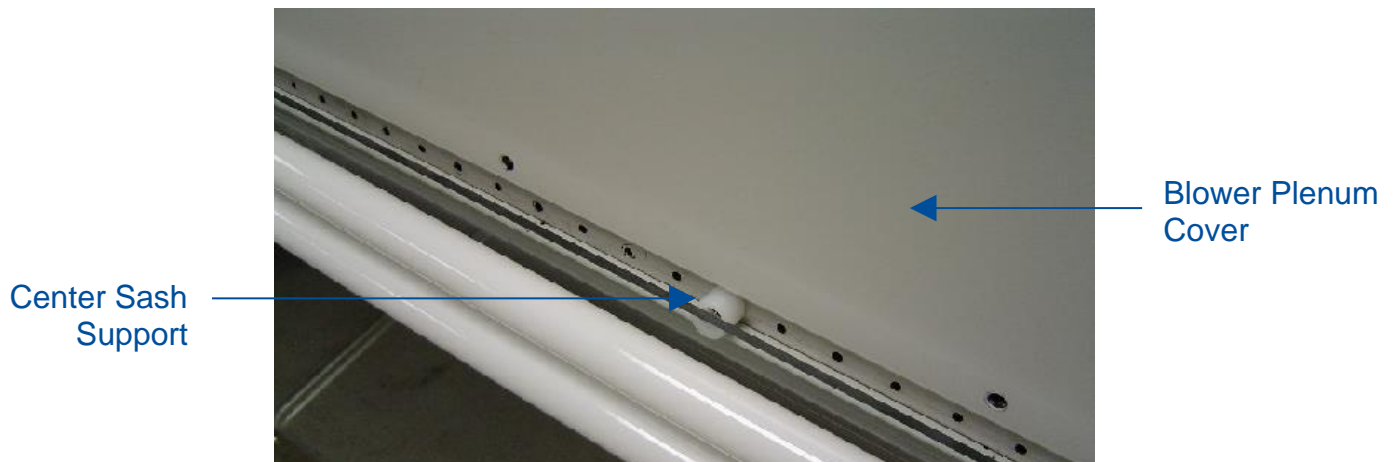


**Figure 12-20**



4. Remove the last two screws. The blower/plenum cover will rest on the center sash support (Figure 12-21) after the final screws are removed. Gently break the gasket seal on the cover by starting in one corner. Use a flat screwdriver if necessary, taking care not to damage the gasket or panel by prying too hard in one area. Once the gasket seal is free, slide the cover to the left or right, and bend it slightly to free one end by getting it past the corner post. Lift the blower/plenum cover off.

**Figure 12-21**



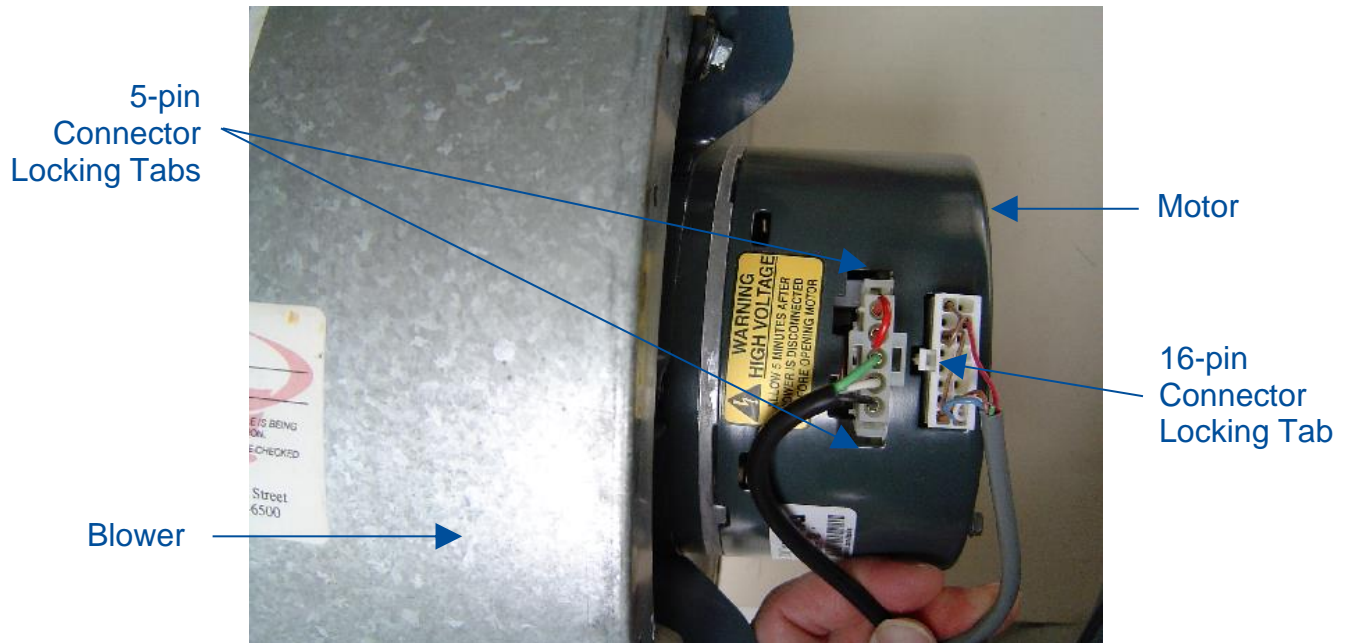
5. Locate the blower/motor assembly, it will be on the right side of the compartment, and resting atop the large, metal plenum.



6. Double check all power has been removed from the biosafety cabinet.

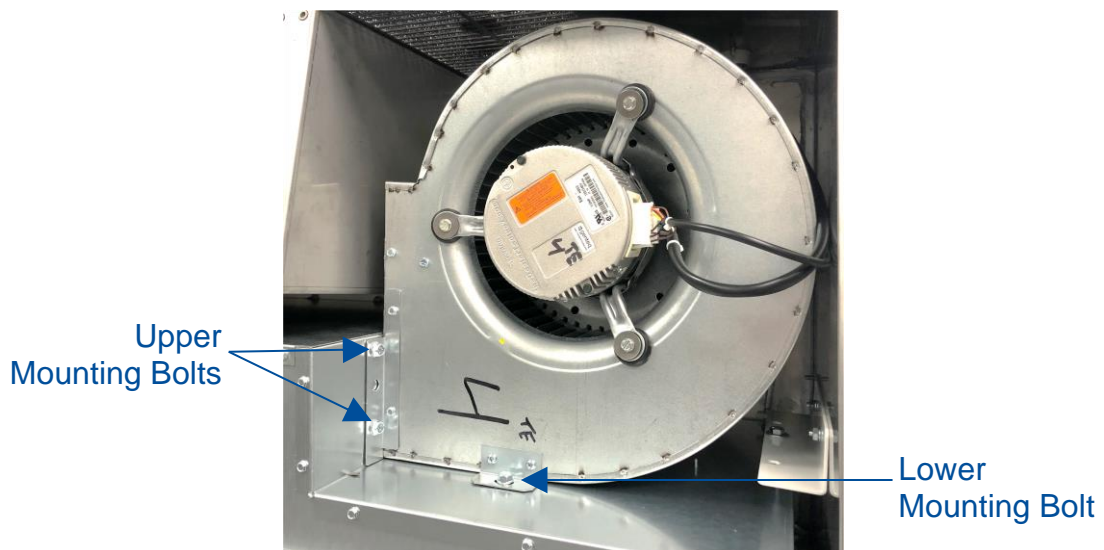
7. Disconnect the two (2) wire harness connections from the motor. The 5-pin connector, located closest to the blower, is released by depressing the locking tabs on either side of the connector. The 16-pin data connector is released by depressing the single locking tab in the center of the connector, on the side of the connector closest to the blower. See Figure 12-22.

**Figure 12-22**



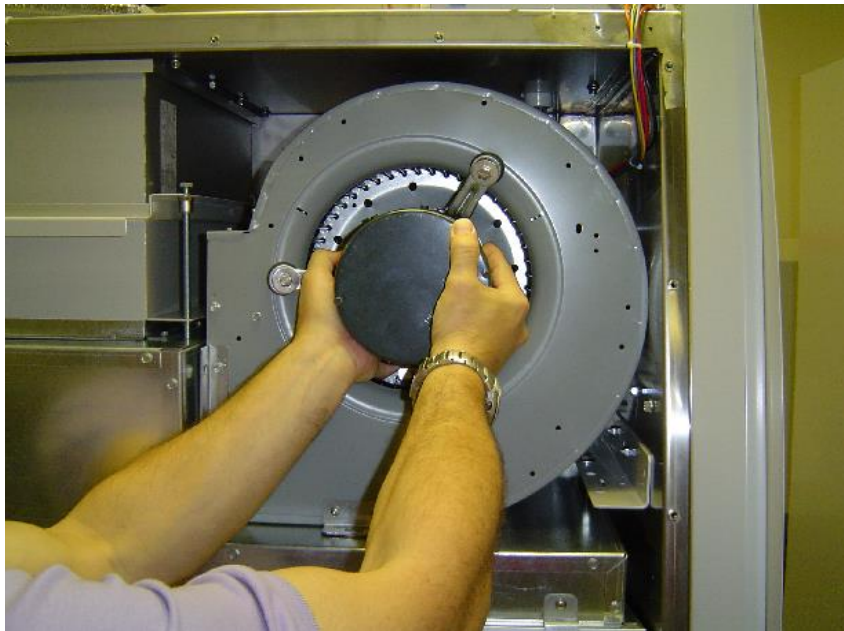
8. Using a 1/2-inch socket or wrench, remove the two upper and one lower mounting bolts. See Figure 12-23.

**Figure 12-23**



9. Grasp the motor and pull the assembly straight out of the biosafety cabinet. See Figure 12-24.

**Figure 12-24**



Note: All 8-foot Type A2 models have two (s) sets of HEPA filters.

10. If conducting filter replacement on an 8-foot model, repeat steps 3 through 9 on the other side.

#### Reinstallation Notes:

1. During reinstallation of the blower/motor assembly, angle the rear blower bracket into the plenum opening. Make sure this rear blower bracket is **INSIDE** the plenum opening. Once reinstalled, and the three blower mounting bolts are installed and tightened, verify the rear blower bracket is positioned correctly by trying to rotate/move the blower/motor assembly. If the entire assembly is rigid (does not move in any direction), the rear blower bracket is properly secured.

### Changing the LED Lamps



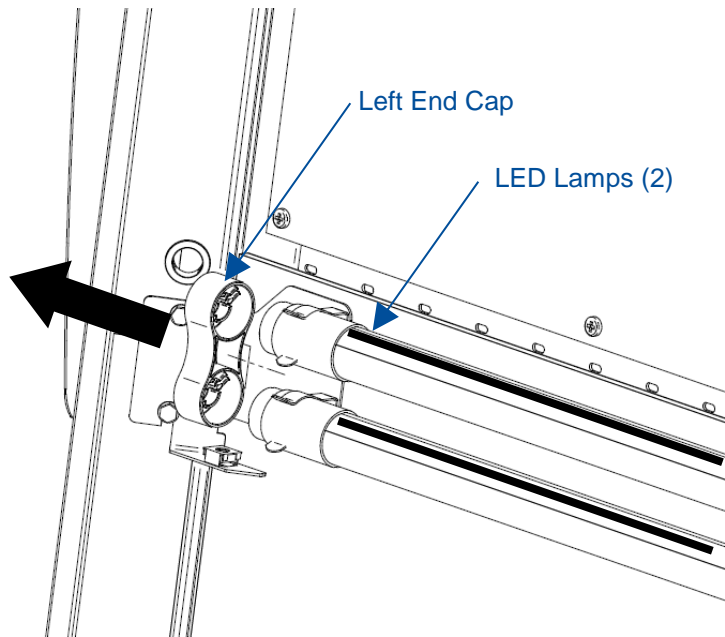
Before proceeding, make sure all electrical power has been removed from the cabinet by disconnecting the main electrical connection, which is the power cord.



This product uses only LED direct drive lighting. Do **NOT** install fluorescent bulbs.

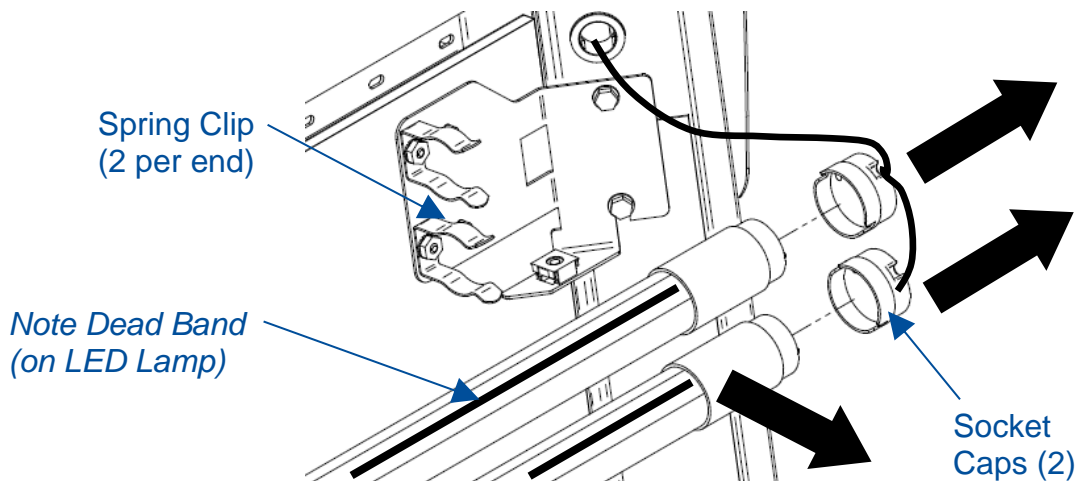
1. Remove the Dress Panel as described in *Removal of External Dress Panels*.
2. Locate the Left End Cap that aligns both LED lamps (Figure 12-37), remove the Left End Cap by pulling it away from the lamp ends.

**Figure 12-37**



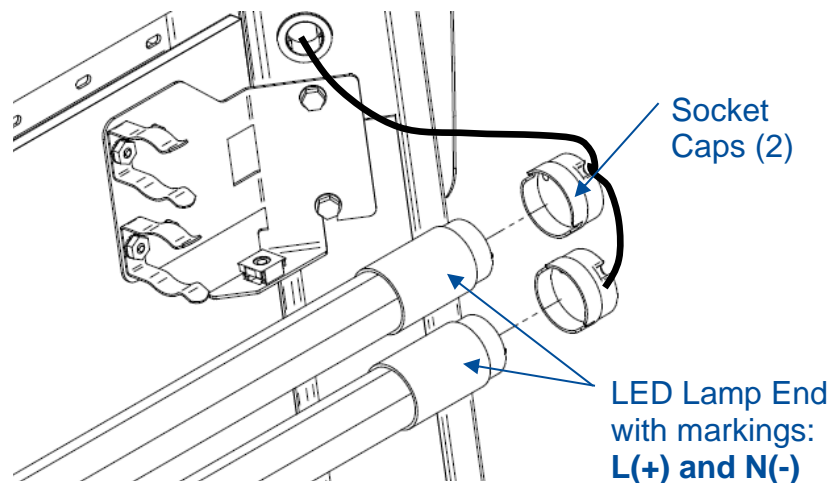
3. Remove both Socket Caps (on the right end of each LED lamp) by pulling each Socket Cap straight off the right end of the lamp one at a time (Figure 12-38).

**Figure 12-38**



4. Pull each LED Lamp straight toward you to release the lamp from the two Spring Clips holding it in place (Figure 12-38). Note the rotational position of the old LED lamps (there is a dead band stripe that will need to be oriented the same when reinstalling the new LED Lamps).
5. Install the new LED Lamps by reversing the removal procedure. Take care to look at both ends of the new LED Lamps. One end is labeled with a '+' & '-' and 'L' & 'N' (Figure 12-39). This end of the new LED Lamp must go to the right, and is inserted into the Socket Cap.

**Figure 12-39**

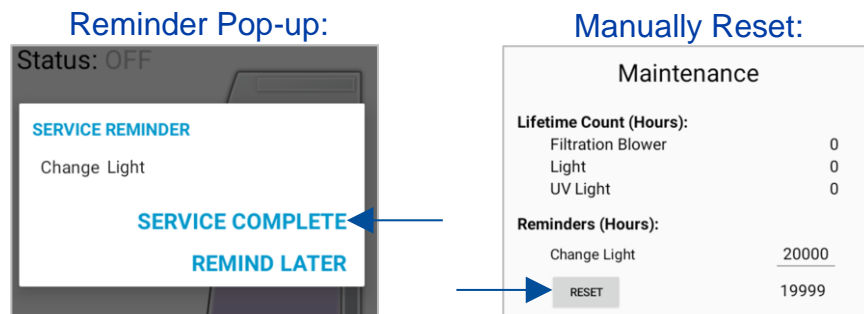


6. When reinstalling the Left End Cap, the pins on each LED Lamp must align rotationally with the Left End Cap. This ensures the dead band stripe is positioned correctly for maximum cabinet lighting.



Reset the Light hourmeter by one of the following methods:

1. Automatically reset by touching **[Service Complete]** on the reminder pop-up.
2. Manually reset by going to *Settings*>*Maintenance* and touching **[Reset]** under *Change Light*. You will be prompted to input your name or organization. When complete, touch **[Next]**.

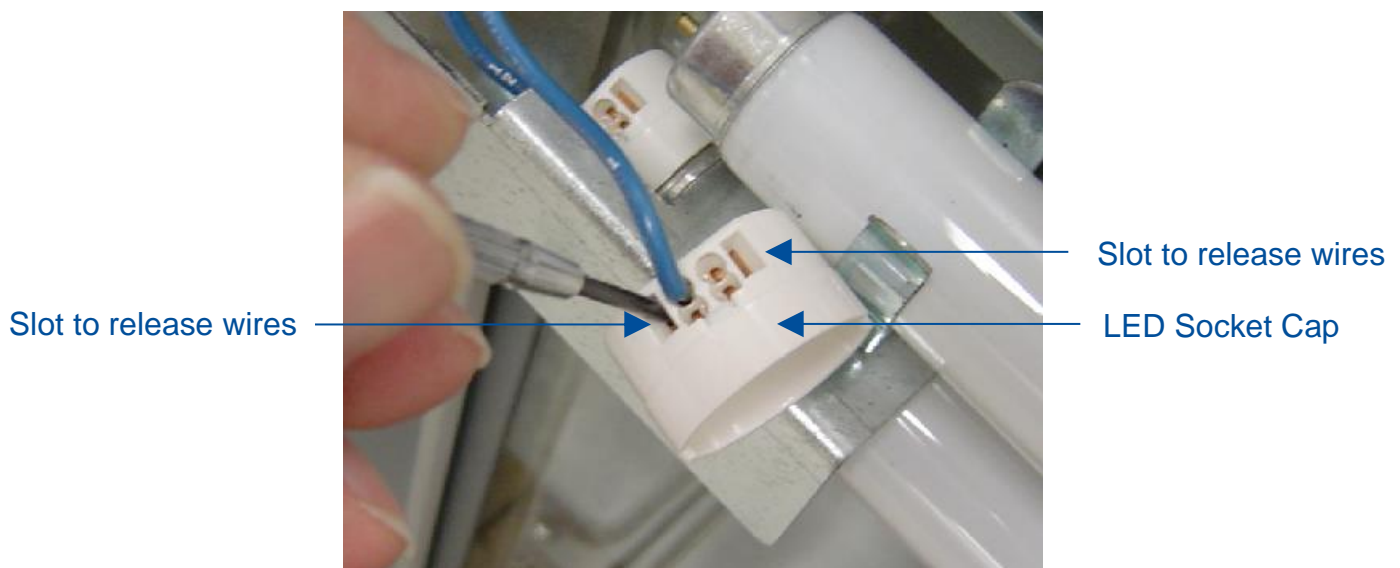


## LED Lamp Socket Cap Replacement

If a lamp socket cap for the LED lamps is damaged and needs to be replaced, follow these instructions.

1. Unplug the cabinet from all electrical power.
2. Remove the front Dress Panel as described earlier in *Removal of External Dress Panels*.
3. Remove the LED lamps from the socket caps as described in the previous section *Changing the LED the Lamps*.
4. To replace a socket cap, insert a small straight bladed screwdriver into the socket near the lamp wire, as shown in Figure 12-40.

**Figure 12-40**



5. Once both wires are removed from the socket, the socket cap is free to be discarded, and the new socket reassembled.

Reinstallation notes:

1. Be sure to press each wire into the holes on the new LED socket cap until they are locked in place. Try pulling each wire back out after inserted, if they will not come out, they are inserted correctly.

## Changing the Optional UV Lamp

The UV Lamp is an optional feature and may not be found on all models.



THE UV LAMP IN THIS PRODUCT CONTAINS MERCURY

Manage in accordance with local disposal laws. DO NOT place lamps in trash. Dispose as a hazardous waste. For information regarding safe handling, recycling and disposal, consult [www.lamprecycle.org](http://www.lamprecycle.org)

CETTE LAMPE (UV) DANS CE PRODUIT CONTIENT DU MERCURE

Éliminez ou recyclez conformément aux lois applicables. Pour de l'information concernant des pratiques de manipulation sécuritaires et l'élimination sécuritaire et le recyclage, veuillez consulter [www.lamprecycle.org](http://www.lamprecycle.org)



For optimum performance, the UV lamp should be changed as indicated by the UV lamp hourmeter found in the [Settings Screen](#)>[Maintenance Screen](#). A pop-up will occur when the hourmeter expires.

The UV lamp and the work area of the cabinet must be thoroughly decontaminated before removing the lamp.

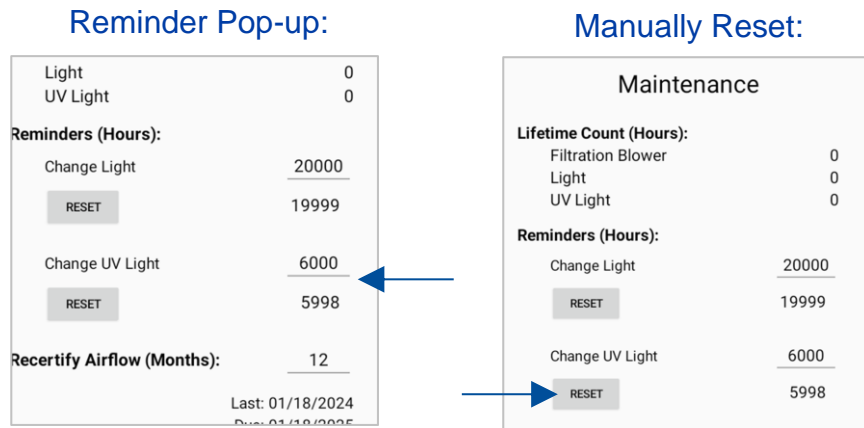


1. Start the cabinet blower and let it operate for 5 minutes.
2. Raise the sash to its full open position.
3. Thoroughly surface decontaminate the UV lamp(s) and the work area of the cabinet.
4. Unplug the cabinet from all electrical power.
5. Remove the UV lamp(s) by rotating it 90 degrees and pulling it straight up and out of the sockets.
6. Install new lamp(s) by reversing the removal procedure.



Reset the UV Light hourmeter by one of the following methods:

3. Automatically reset by touching **[Service Complete]** on the reminder pop-up.
4. Manually reset by going to *Settings>Maintenance* and touching **[Reset]** under *Change UV Light*. You will be prompted to input your name or organization. When complete, touch **[Next]**.



## UV Lamp Socket Replacement

If a lamp socket for the UV lamp is damaged and needs to be replaced, follow these instructions.

1. Start the cabinet blower and let it operate for 5 minutes.
2. Raise the sash to its full open position.
3. Thoroughly surface decontaminate the UV lamp and the work area of the cabinet.
4. Remove the UV lamp by rotating it 90 degrees, then pull it straight out to free it from the sockets.
5. Use a #1 Phillips screwdriver to remove the screw by the defective socket.
6. Rotate the defective socket and pull it out of the cutout in the baffle.
7. Disconnect the two wire connections, and treat the defective socket as contaminated biohazardous waste when disposing of it.
8. Install the new socket.

## Type B2 Prefilter Replacement

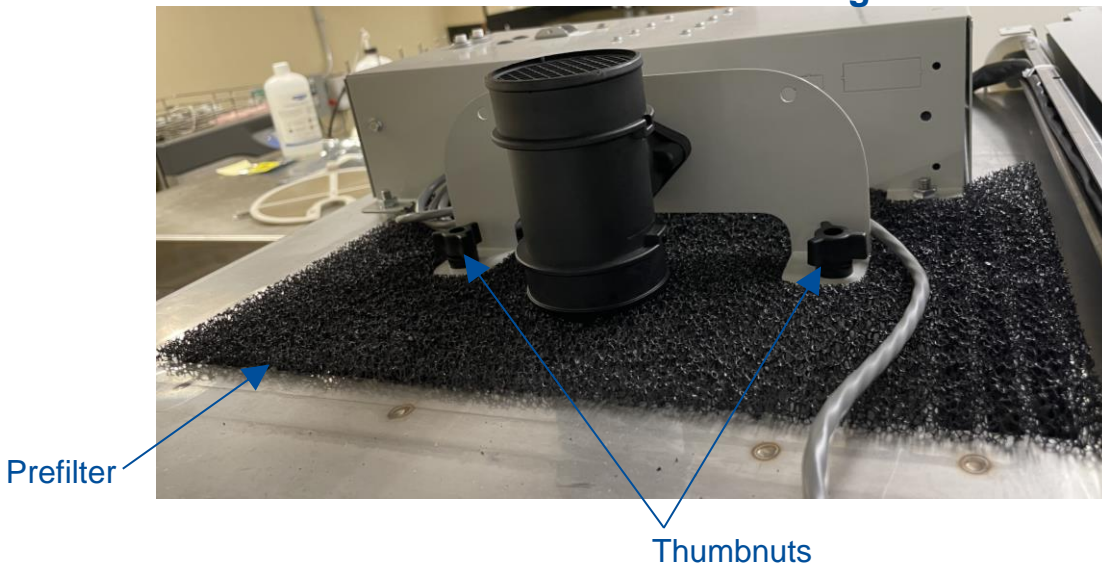
A Type B2 biosafety cabinet has a prefilter on top of the cabinet, to the left of the electronics module. This prefilter removes large particulate from the room air drawn into the biosafety cabinet by the supply blower. When this prefilter becomes loaded with particulate, replace it as follows.



**Note:** The prefilter is not washable, it must be replaced when dirty.

1. Turn off the biosafety cabinet's blower.
2. Following all facility safety requirements, use a step ladder to access the prefilter atop the biosafety cabinet.
3. Remove the two thumbnuts that hold the prefilter in place. See Figure 12-41.

**Figure 12-41**



4. Remove and replace the prefilter.

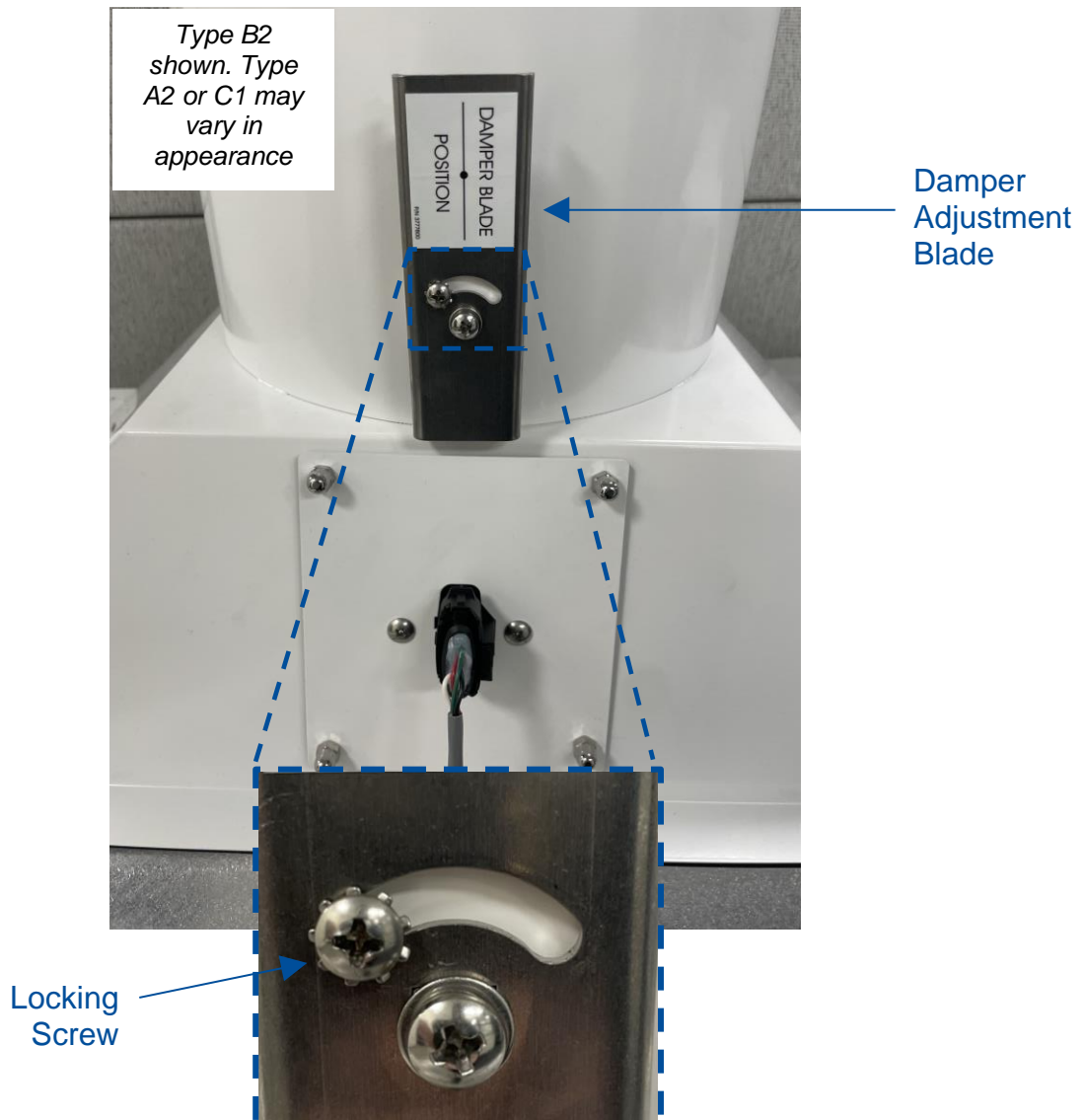
## Air-Tight Damper Adjustment

An air-tight damper is integral to the exhaust housing on a Type B2 biosafety cabinet. It may also be used on a Type A2 or C1 that is connected to a remote (building) exhaust system. The air-tight damper is used to adjust the remote exhaust system airflow drawn from a particular biosafety cabinet to fine-tune the exhaust flow to meet the model's requirements. A remote exhaust connected Type A2 will require the Ventus II canopy

Connection Kit installed for the air-tight damper to be installed above it. To adjust airflow on a Labconco air-tight damper follow these instructions.

1. Locate the damper adjustment blade (see Figure 12-42) on the air-tight damper.
2. Using a #2 Phillips screwdriver, loosen the locking screw on the damper adjustment blade. Adjust the damper blade to allow more or less exhaust air to the biosafety cabinet as needed. Retighten the locking screw.

**Figure 12-42**



## Preparing the Biosafety Cabinet for Gaseous Sterilization



**Note:** This section only reviews the steps required for preparing the biosafety cabinet for gas sterilization. Thoroughly understand the sterilization procedures and protocols supplied by the manufacturer of the sterilizing system before attempting this operation.

1. Consult the sterilization equipment manufacturer to determine if the biosafety cabinet's internal blower(s) should be on or off during the sterilization process.
2. Thoroughly surface decontaminate the working area of the cabinet.
3. Remove the work surface after it has been surface decontaminated.
4. Remove the front grille.
5. Place the work surface and the grille into the work area for decontamination.
6. Remove the front Dress Panel.
7. Remove the sash stop bracket, located near the top of the blower plenum cover.
8. Lift the sash up until the bottom edge of the sash clears the bottom edge of the Supply HEPA Filter shelf.
9. Using flexible plastic sheeting 5-8 mil thick and duct tape, seal the perimeter of the front opening. If you wish to connect the sterilizer's discharge tube to the biosafety cabinet's Upstream Sampling/Decontamination Tube, it is located by the towel catch.
10. Open the exhaust filter cover.



**Note:** DO NOT attempt to remove the brackets that secure the exhaust filter cover; they are needed to maintain rigidity on the top of the chassis.

11. Using flexible plastic sheet and duct tape, seal the exhaust filter opening.
12. The biosafety cabinet is now prepared for gaseous decontamination.

## Service Fixture Installation & Service Connection

Service fixtures are not pre-installed on all models. If connecting a service line to a pre-installed fixture, or installing a service fixture on the biosafety cabinet, follow these instructions. The field install service fixture kit contains additional installation instructions.



**Note:** Some models have a solenoid valve connected to the service valve on the right side, rear position. The solenoid prevents gas from flowing to the service valve when the cabinet's blower is off, or there is a loss of electrical power. It is the only service valve position that can be fitted with a solenoid valve. Connect the gas service to the solenoid valve. The tubing between the service fixture and the solenoid valve is provided.



Safe for use with vacuum, air, carbon dioxide, nitrogen, and argon. Not for use with water, steam or high purity gasses like oxygen and hydrogen. Contact Labconco for additional valve options.

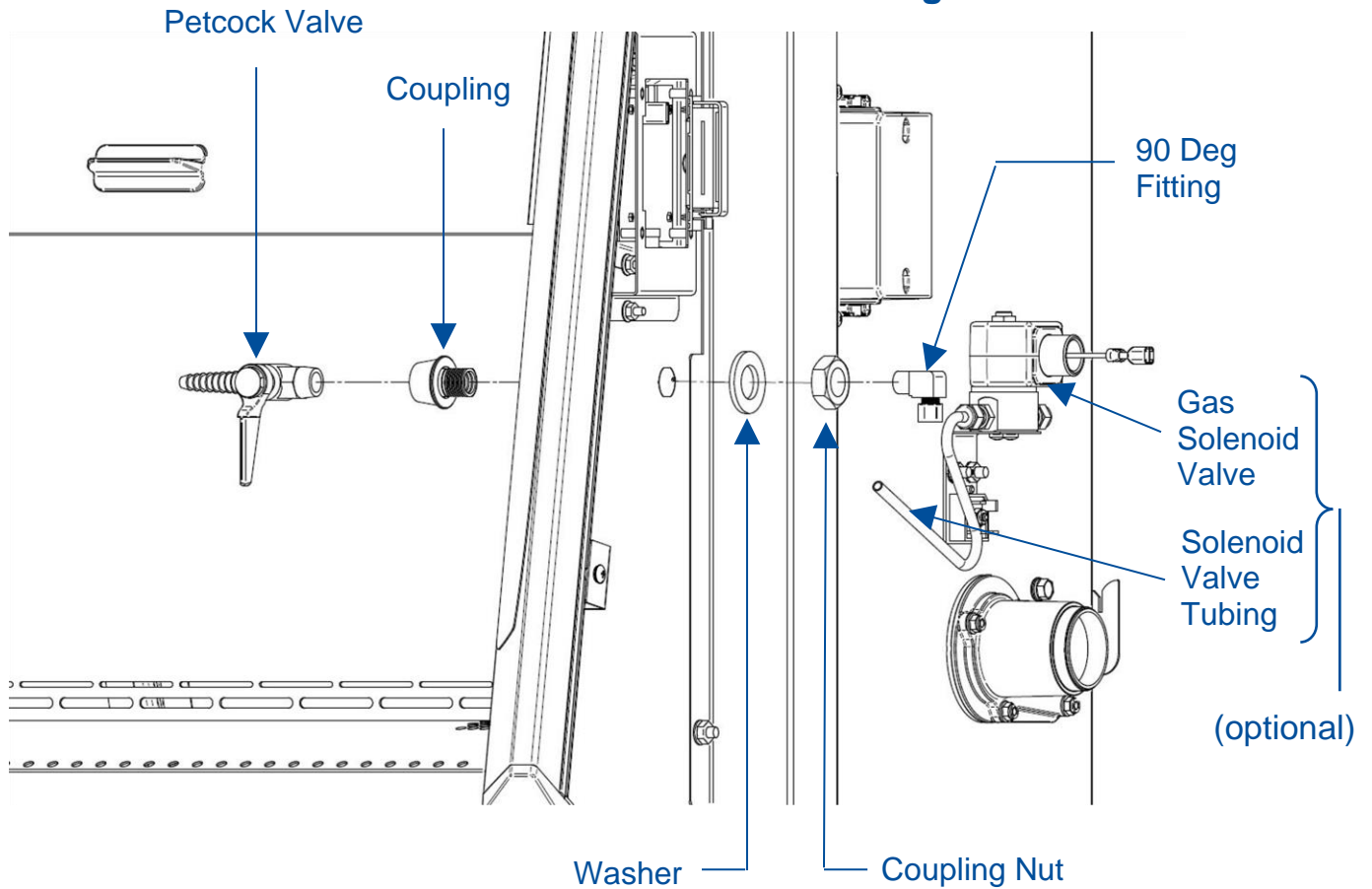
If service fixture is already installed, proceed to Step 9. Reference Figure 12-43 for the procedure below.

1. Remove the right or left Side Panel based on which side the service fixture is to be located, as described in *External Dress Panel Removal* earlier in this section.
2. Identify the appropriate knockout plug on the biosafety cabinet (3 per side are provided on standard models). Using a large, flat blade screwdriver and hammer, remove the knockout by placing the screwdriver on the top or bottom of the plug, strike the screwdriver with the hammer. Repeat alternating between the top and bottom until the plug is loose enough to remove with pliers.
3. Using PTFE pipe thread tape on the male threads of the petcock valve, install the coupling onto the male threads of the petcock valve. Tighten fully.
4. Apply a thin coat of silicone around the knockout opening on the OUTSIDE of the cabinet wall. Apply PTFE pipe thread tape on the male threads of the coupling.
5. Insert the male threads of the coupling through the knockout opening, slide the washer (from the OUTSIDE) over the male threads of the coupling. Install the coupling nut hand-tight.
6. Rotate the petcock valve to position the handle as desired for user operation of the valve. Fully tighten the coupling nut.
7. Apply PTFE pipe thread tape on the male threads of the 90 degree fitting. Install the male threads of the 90 degree fitting into the female threads of the coupling. Tighten fully, taking care to position the compression end of the 90 degree fitting

in the proper position to accept the customer-supplied tubing. Note: if a gas solenoid valve is ordered, the tubing between the 90 degree fitting and the solenoid is Labconco supplied.

8. Close the petcock valve and leak check all connections with an inert gas and appropriate detector. If a leak is found, tighten the appropriate fitting connection further.

**Figure 12-43**



9. Ensure the customer-supplied service line tubing is  $\frac{1}{4}$  inch O.D., soft metal, and that the end has been completely deburred.
10. Route the tubing from the rear or bottom of the cabinet, ensuring that it will line up with the slot in the rear or bottom of the Side Panel. The rear slot is located from  $8 \frac{3}{4}$  to  $11 \frac{1}{4}$  inches (222 to 288 mm) from the bottom of the cabinet.



**Note:** Make sure that the tube routing will not contact any electrical wires. DO NOT loop service line tubing within the Side Panels of the cabinet.

11. Make sure the compression nut on the 90 degree fitting is loose, but do not remove it. Verify the tubing ferrule is in the fitting (just behind/inside the compression nut).
12. Push the tube into the fitting until it is properly seated. The tube will go approximately  $\frac{3}{4}$  inch (19 mm) into the fitting when properly seated.
13. Tighten the 90 degree fitting compression nut hand-tight and then, using a 7/16-inch wrench, tighten it at least  $\frac{3}{4}$  turn more.
14. Close the service valve in the cabinet and then slowly open the shutoff valve on the service valve. Test all fittings for leakage. Tighten the tube nut slightly if needed.

## 13: Electrical Components

---

This section details the electrical components found on the biosafety cabinet.

### Electronics Module

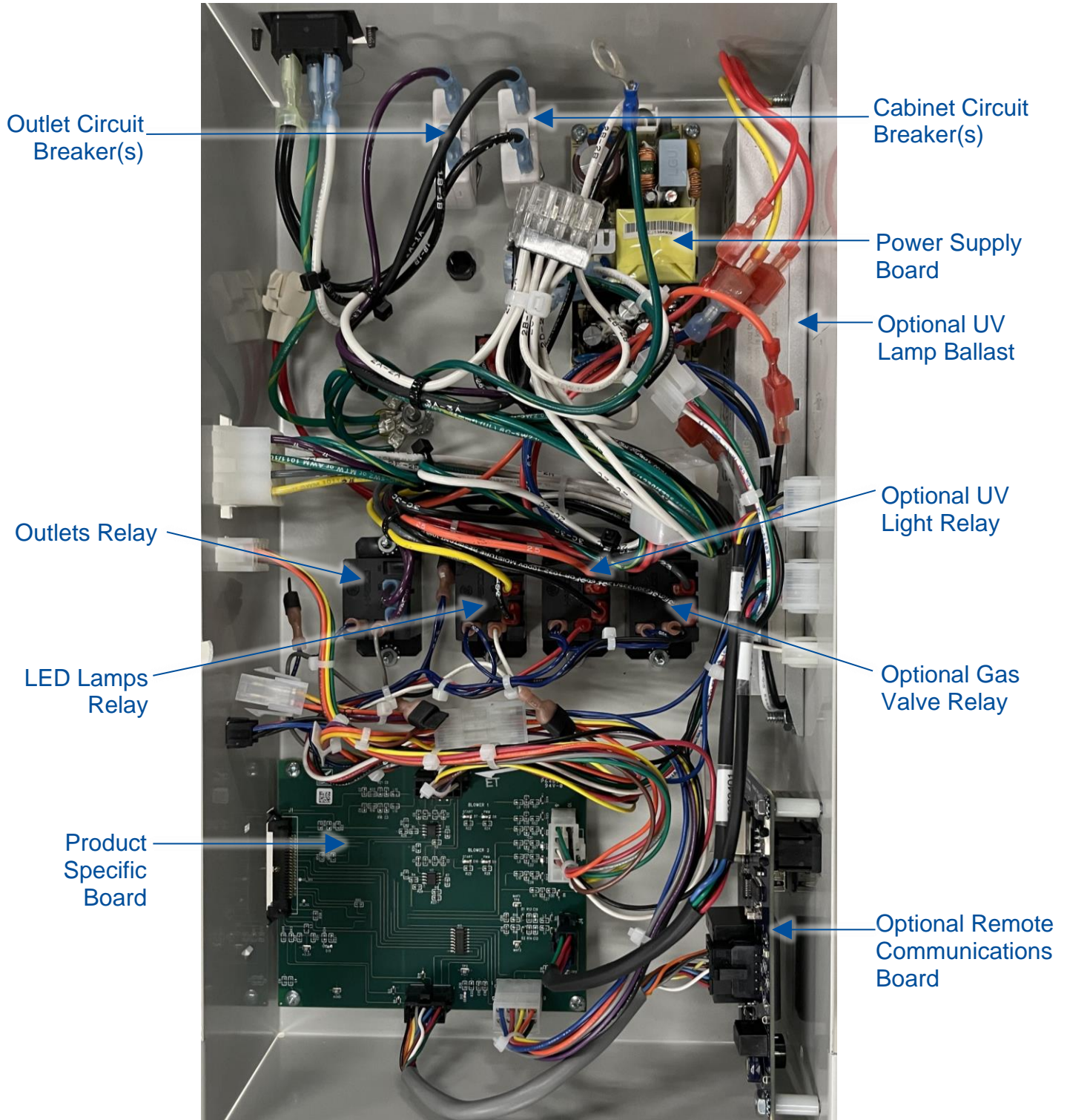
The electronics module is located on the top, right side of the biosafety cabinet. To access the module, follow these instructions.

1. Remove all power from the biosafety cabinet by unplugging the power cord.
2. If cabinet has an exhaust cover, remove the two phillips screws on the front face of the cover and lift the cover up and out of the way. Fully remove or use the prop as needed. For more detailed instructions, see *Removal of External Dress Panels: Exhaust Cover* in [Section 12: Advanced Service Procedures](#).
3. Using a 7/16-inch socket or nut driver, remove the four nuts holding the module to the top of the biosafety cabinet. Each corner of the module is secured with a nut.
4. Tip the module on its side, and secure it. To completely remove the electronics module, follow the additional steps below.
5. With the module secured on its side, locate the green/yellow ground wire towards the rear of the module. It is still connected to the top of the biosafety cabinet with a ground nut. Using a 7/16-inch socket or nutdriver, remove the ground nut and free the ring terminal connected to the end of the green/yellow wire.
6. It is still connected to the top of the biosafety cabinet with two wiring harnesses coming out of the top of the cabinet. Locate the 9-pin connector, depress the locking tabs on either side of the connector to release. Locate the 4-pin connector, depress the single locking tab in the center of the connector to release.
7. Remove the electronics module.

## Electronic Module Components

The electronics module contains the circuit breakers, AC relays, power supply board, Product Specific board, Remote Communication Board (optional), and UV lamp ballast (optional). These components are identified in Figure 13-1.

**Figure 13-1**



## Resetting a Circuit Breaker

Should an over current situation arise during normal operation, the circuit breakers located on the top surface of the electronics module will trip, protecting the cabinet from damage.

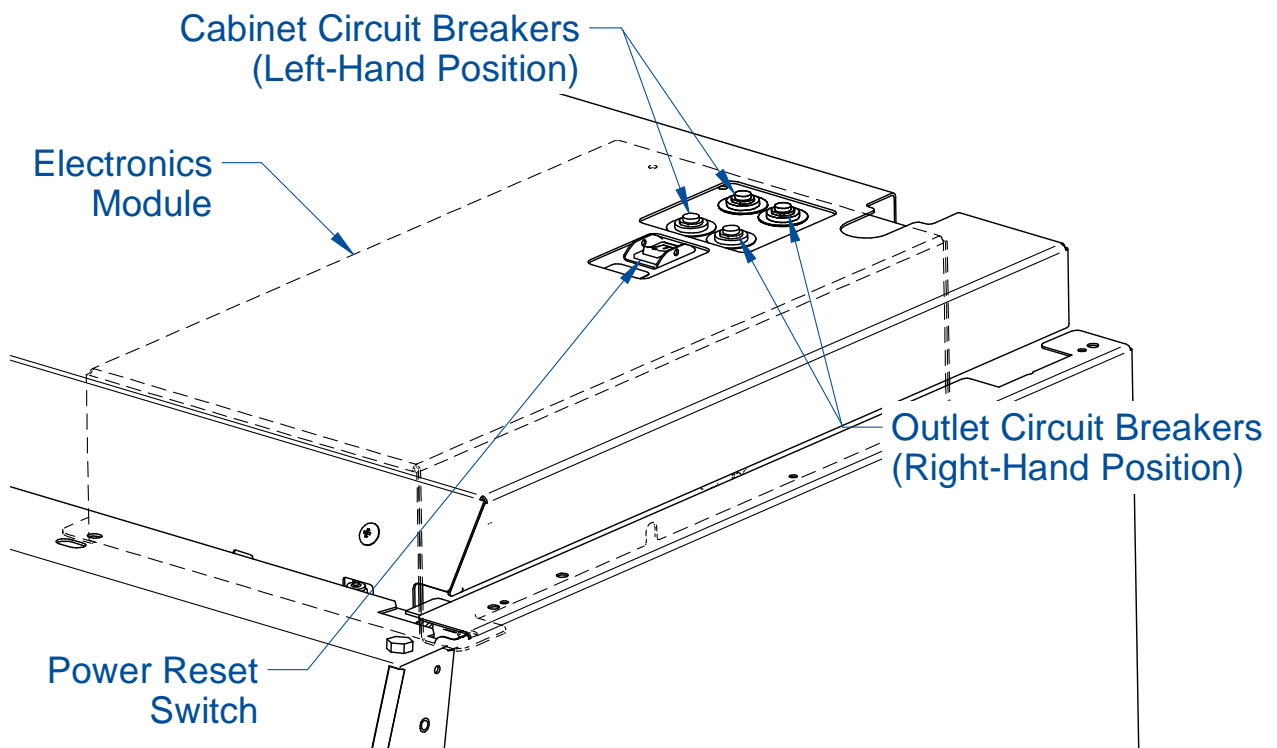
The biosafety cabinet offers internal outlets to power small devices inside the cabinet. The internal outlets are protected by one circuit breaker (two circuit breakers on 230v models), and the cabinet electronics are protected by a different circuit breaker (two different circuit breakers on 230v models). This allows the cabinet to continue to operate, providing protection to the product and user, should a device connected to an internal outlet experience an over current situation.

If the internal outlets do not have power when the **Outlet** icon is displayed on the Home Screen, reset the appropriate circuit breaker(s) as shown in Figure 13-2. The outlet circuit breaker(s) are in the Right-Hand Position(s).

If the cabinet does not have power when the System Reset Switch (Figure 13-2) is on, reset the appropriate circuit breaker(s) as shown in Figure 13-2. The cabinet circuit breaker(s) are in the Left-Hand Position(s).

The thrown circuit breaker will be easy to identify, as the white barrel will be extended further than the other circuit breaker(s). To reset, simply push it in.

**Figure 13-2**



## Power Supply

The power supply converts the AC voltage supplied through the power cord to DC voltage to power the relays and microprocessor. It is an open-frame, single output (12VDC) voltage power supply. If the power supply is not operational or defective, the LCD Display will not power on, and the biosafety cabinet will not function. See Figure 13-3.

**Figure 13-3**

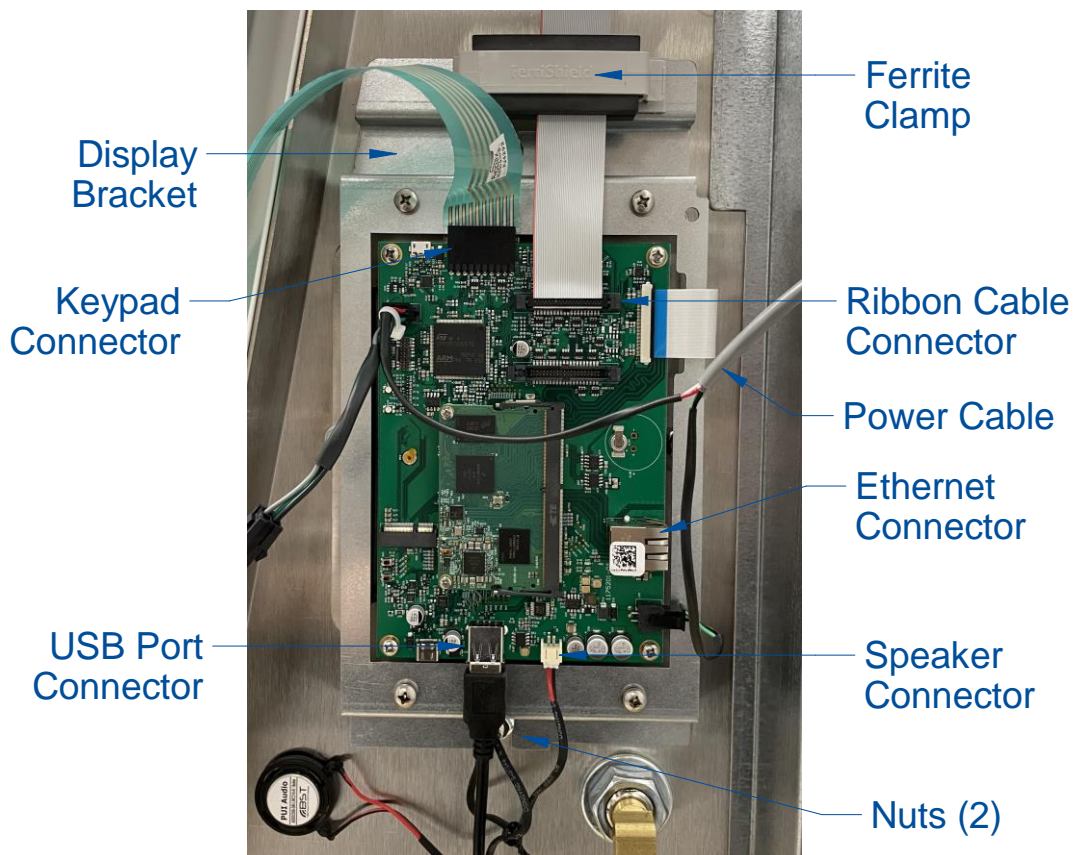


## Display Board

The LCD display and circuit board assembly contain the microprocessor which controls all functions of the biosafety cabinet. The data ribbon cable, keypad cable, USB port cable, power cable, and speaker cable all connect to the display board. To replace the display board, follow these instructions.

1. Open the right-hand Side Panel as described in *Removal of External Dress Panels* in [Section 12: Advanced Service Procedures](#).
2. Disconnect the six wire connections to the display board, see Figures 13-4 and 13-5 for reference. **Note:** Speaker connector easier to remove after Step 3.
3. Using a 3/8-inch socket or nut driver, remove the two nuts securing the display bracket. See Figure 13-4 for reference. The display board is attached to the display bracket, and will come with the display bracket. Remove the display bracket.

**Figure 13-4**

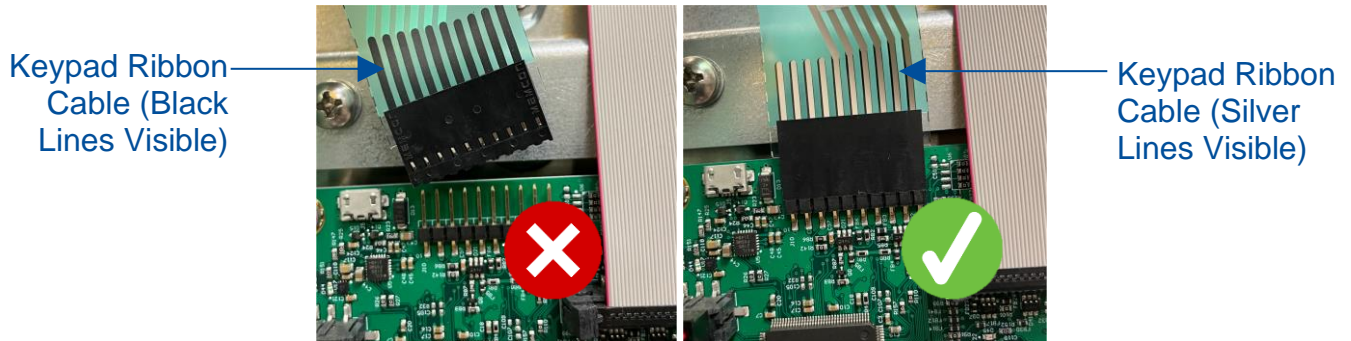


4. Using a #2 Phillips screwdriver, remove the four (4) screws holding the display board to the display bracket.

## Reinstallation Notes:

1. When reconnecting the keypad connector to the display board, it can be assembled correctly or backwards. The correct orientation is for the visible silver lines on one side of the keypad connector ribbon to face away from the LCD display screen on the display board. See Figure 13-5 for reference.

**Figure 13-5**



## Speaker

The speaker produces all audible alarms and tones. It connects to the display board. To replace the speaker, follow these instructions.

1. Disconnect the speaker wire connector from the display board. See Figure 13-6.
2. Using a putty knife, or similar instrument, dislodge the speaker from the biosafety cabinet's liner. See Figure 13-6 for reference.
3. If the adhesive holding the defective speaker to the liner wall is too difficult to remove, the defective speaker can be left in place, and the new speaker adhered next to it.

**Figure 13-6**



## Blower Motor

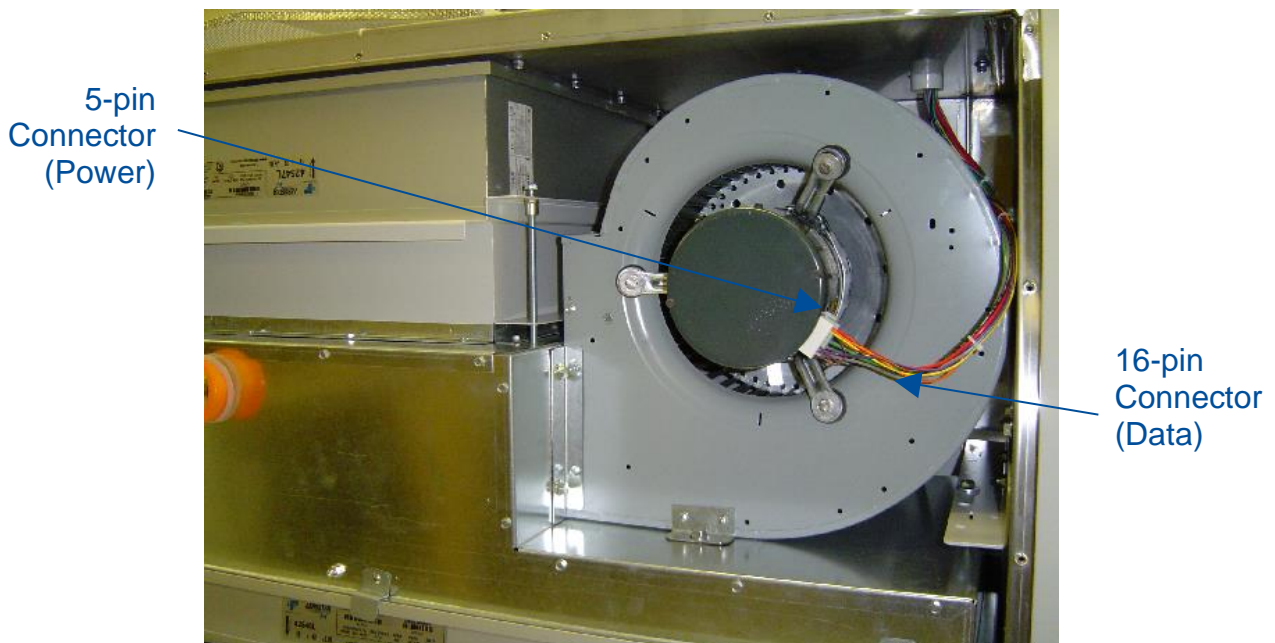
The blower motor(s) on the biosafety cabinet require a power connection (with AC voltage) and a data connection. The AC power supplied to the motor electronic module is converted to DC inside the motor. The motor is an ECM (electronically commutated motor), which is a brushless DC motor. The electronics head is programmed by Labconco for each particular model to operate in constant volume to deliver correct airflows even as the HEPA filter loads with particulate. If troubleshooting a non-responsive blower motor, use the following information.



In order to confirm proper voltage presence on the motor, the biosafety cabinet must have power supplied to it. Take extra care when testing these wires to avoid electrical shock.

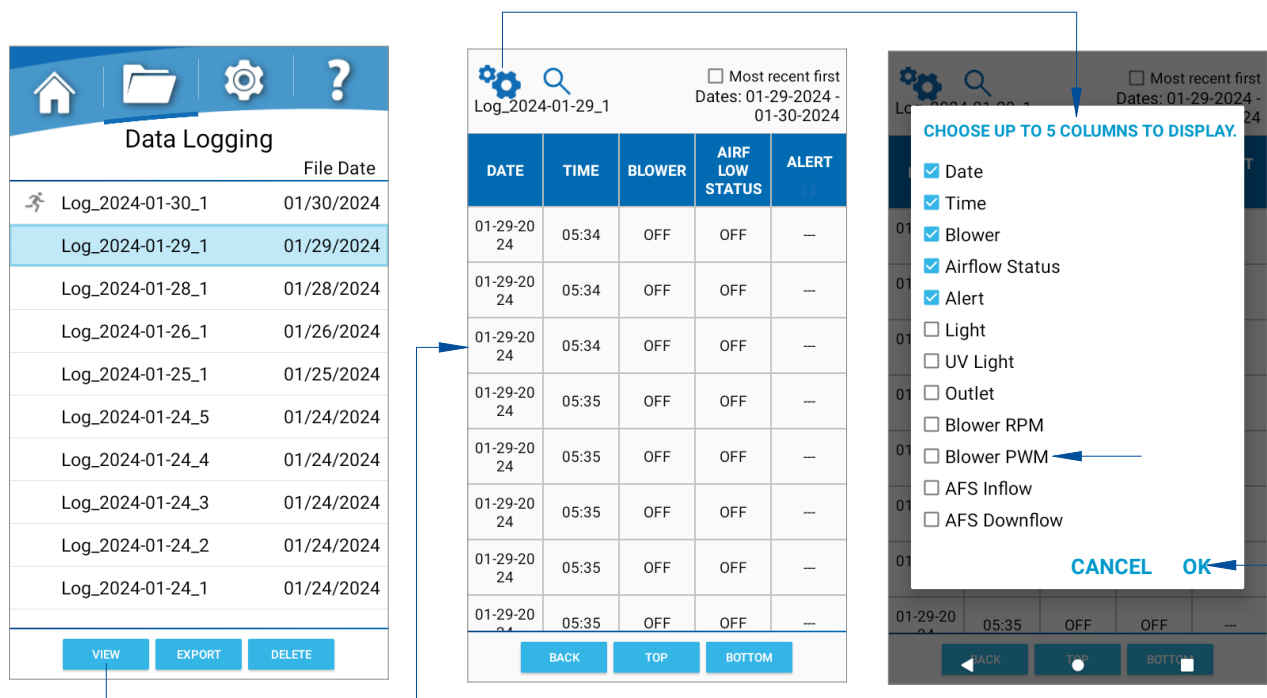
1. The following wiring information lists each wire color as it enters the motor. Since the motor is in a contaminated area of the biosafety cabinet, it may be desired to trace these wires back to the top electronics module to verify voltages without opening the contaminated areas of the biosafety cabinet.
  - a. The AC line voltage supplied to the biosafety cabinet (100v, 115v, or 208/230v) should be present on the power connector across pins 4 (black wire) and 5 (white wire).
  - b. 10-12VDC should be present on the data connector across pins 1 (brown) and 15 (yellow).
  - c. A pulse width modulation signal (PWM) should be present on the data connector across pins 1 (brown) and 10 (purple).

**Figure 13-7**



2. To verify the PWM measured in step 1c (above) is correct, follow the steps below:
  - a. To access the *Data Log Menu* from the *Home Screen*, press **[Data Logs]** (represented by the folder-icon) on the Menu Bar of the display.
  - b. Select and touch a log. Touch **[View]**.
  - c. Locate the heading that mentions the Blower PWM. If not visible, touch the **[Gears]** Icon in the corner of the display and select all available options mentioning *Blower PWM*. Other fields may need to be deselected to select the PWM options. Touch **[OK]**.
  - d. Note the PWM value. Touch **[Back]** to exit the log view.

Figure 13-8

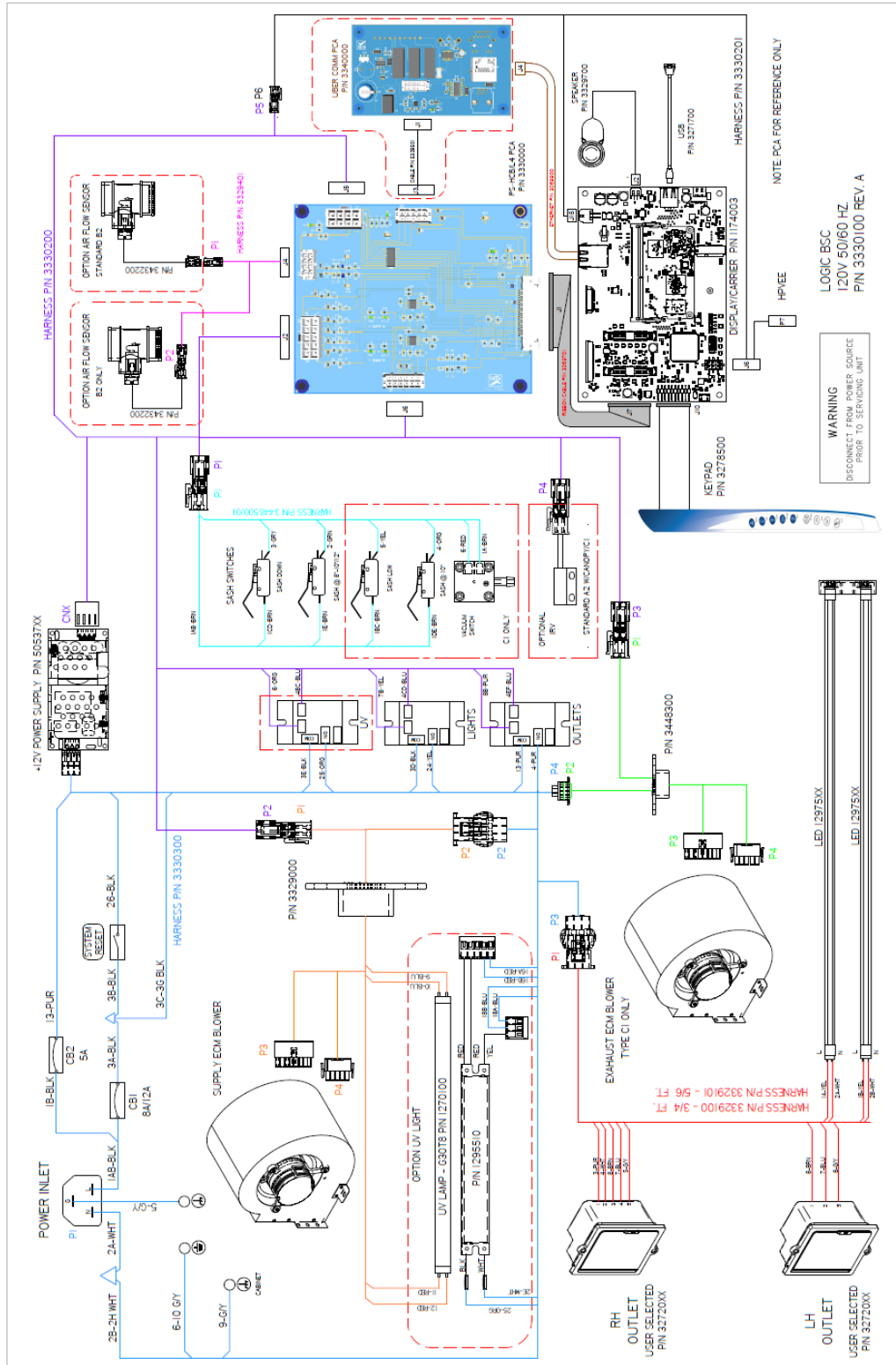


3. Divide the PWM voltage measured in step 1c (above) by the DC voltage measured in step 1b (above). For example, 13.7 volts measured across pins 1 & 10 (PWM line), and 23.7 volts measured across pins 1 & 15.  $[13.7] / [23.7] = 0.58$ . This means the PWM signal is  $0.58 = 58\%$ . The *Blower PWM* value displayed under the *Data Log Viewer* screen (above) should match this calculated value within 3%.

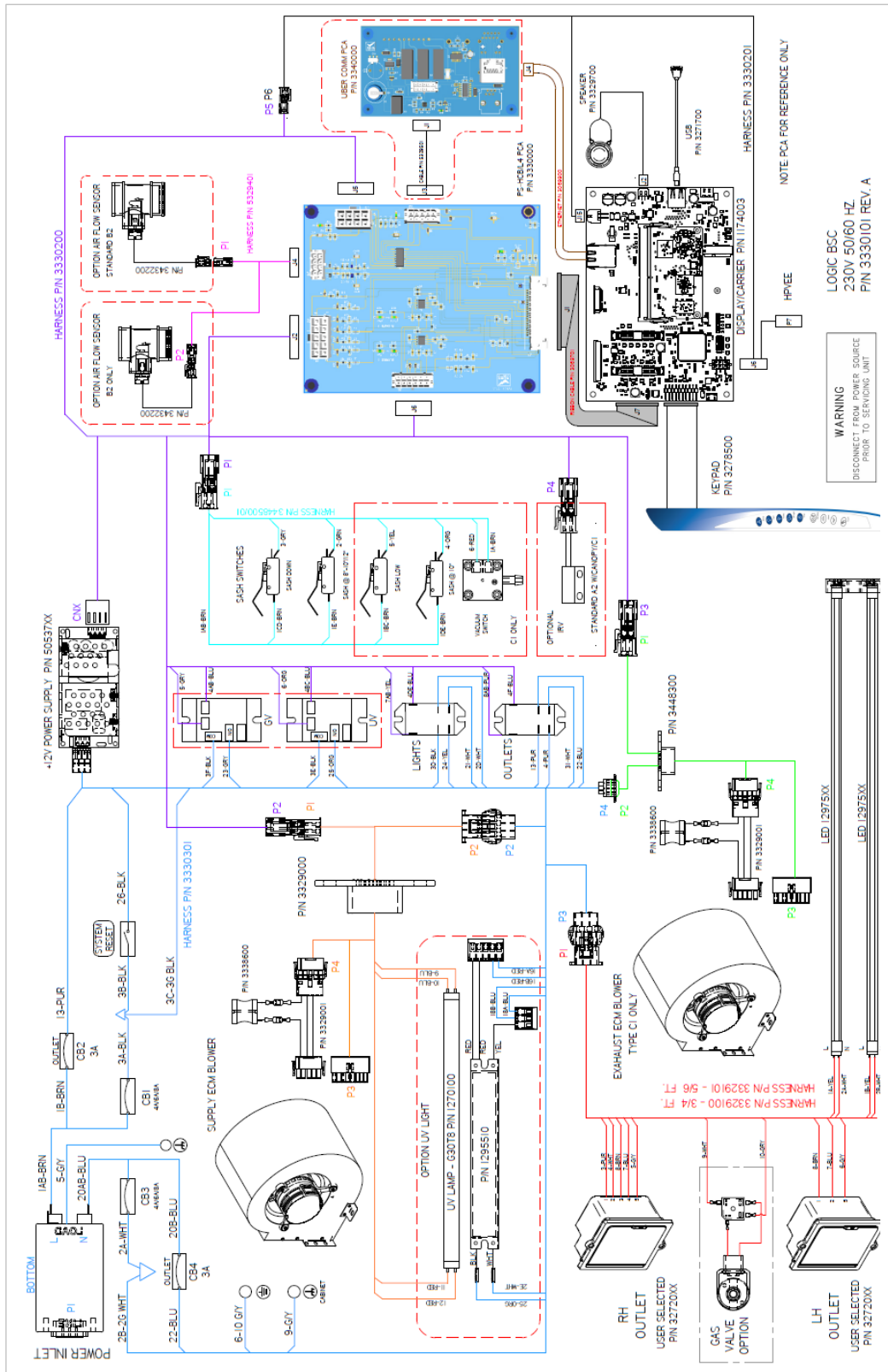
# Wiring Diagrams

The wiring diagram is also located on the blower/plenum cover behind the Dress Panel.

100-115V – 3-ft, 4-ft, 5-ft, & 6-ft



208-240V — 3-ft, 4-ft, 5-ft, & 6-ft





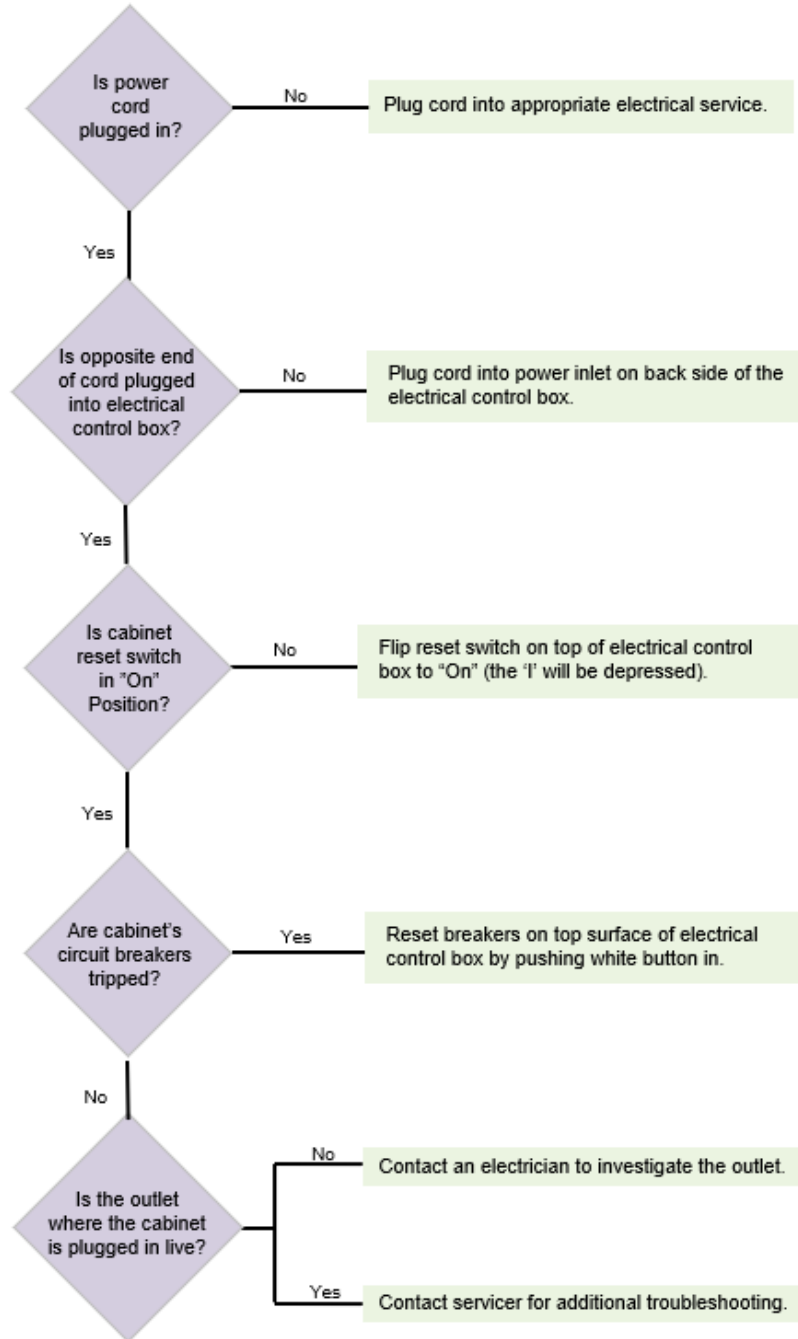


# 14: Troubleshooting

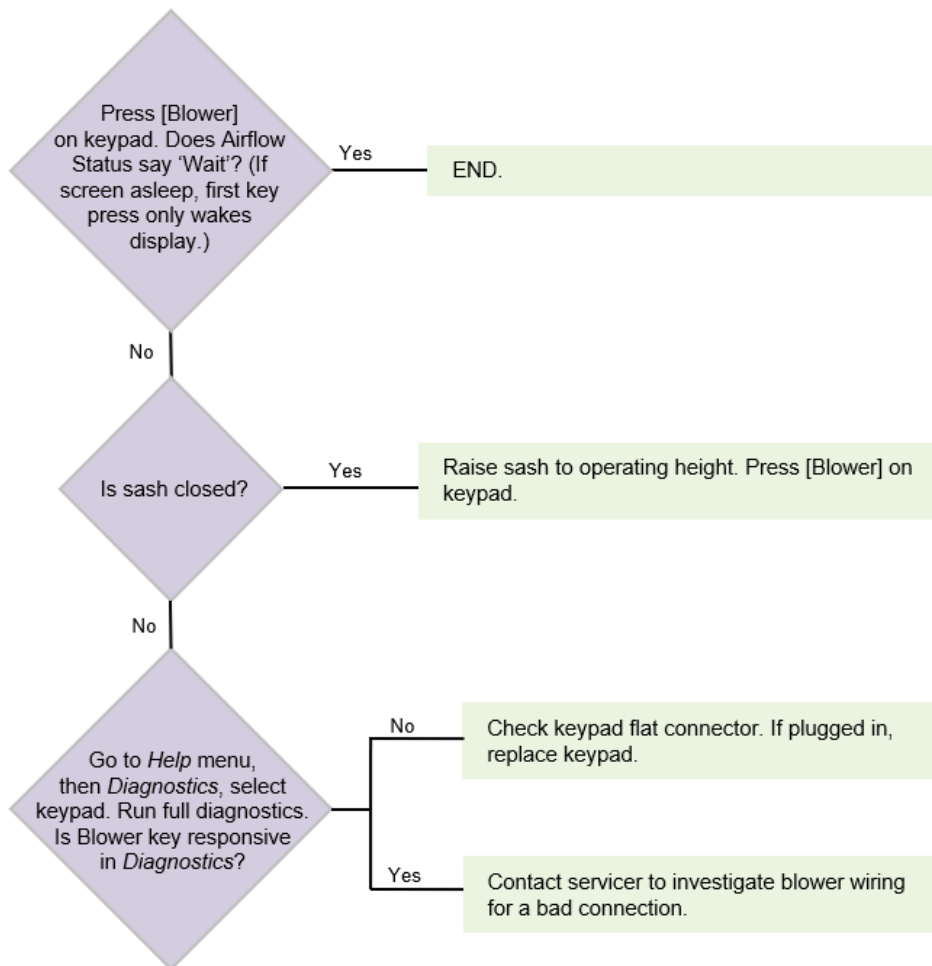
---

This section details common troubleshooting for the biosafety cabinet.

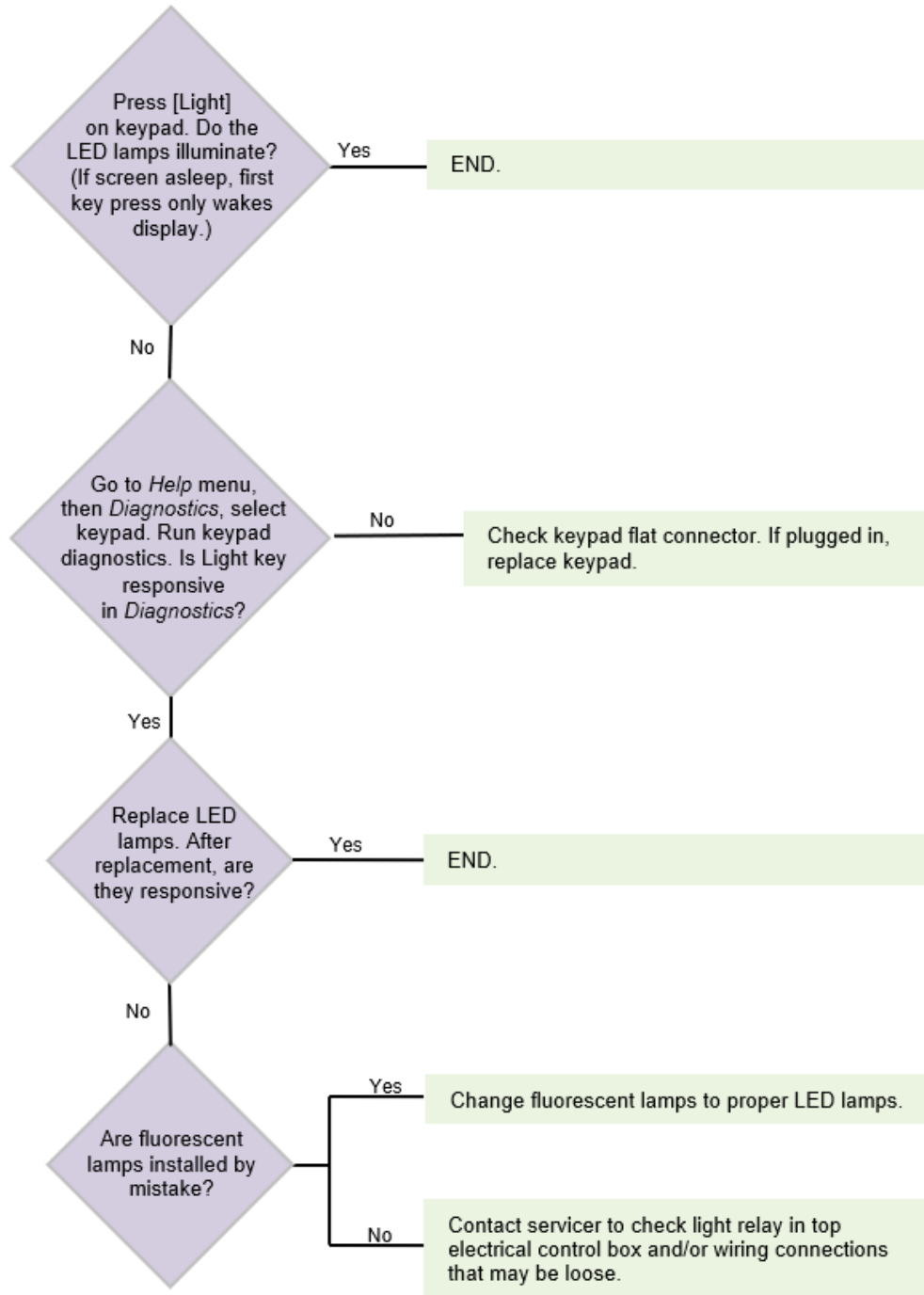
## Blower and Lights not working



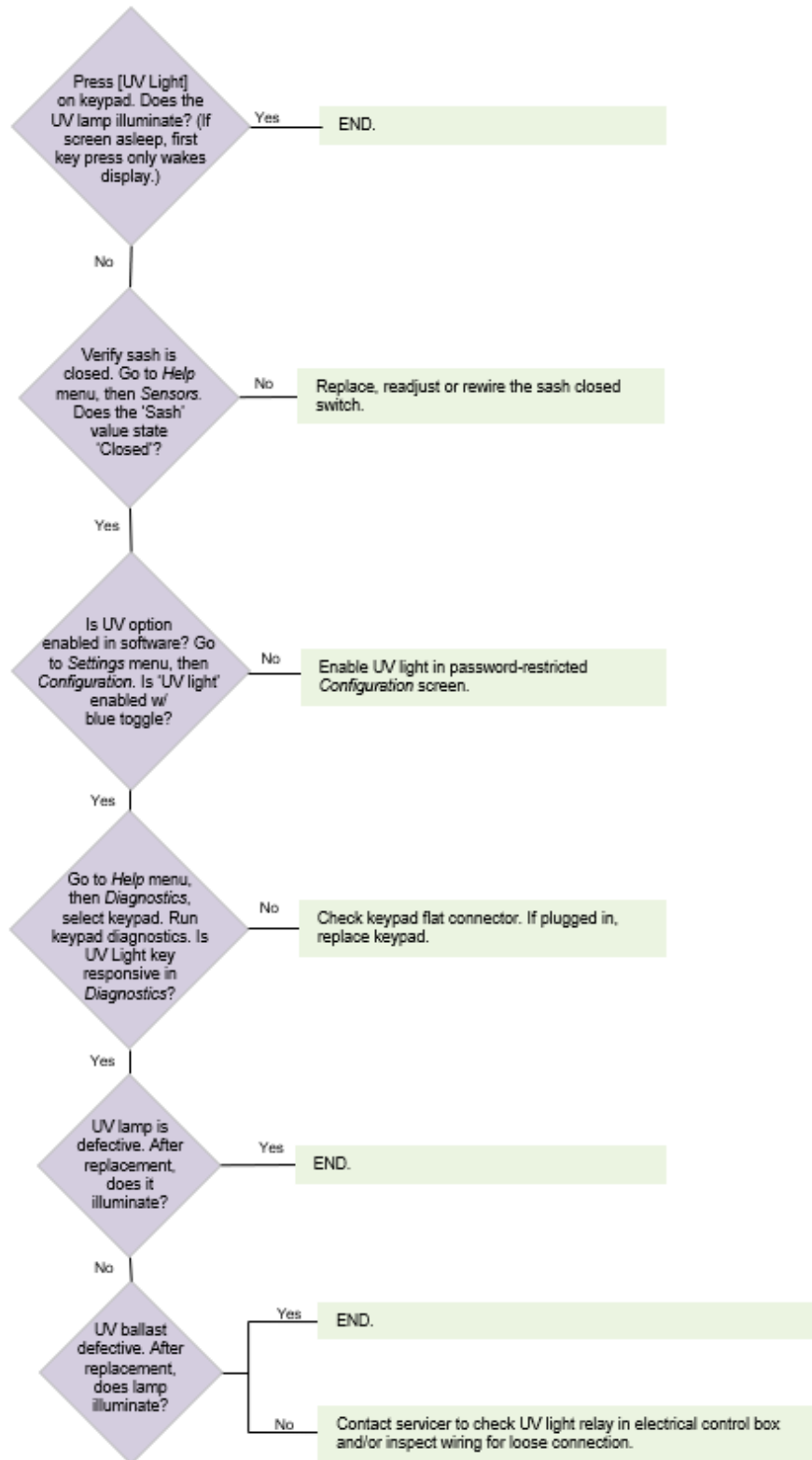
## Blower only will not start



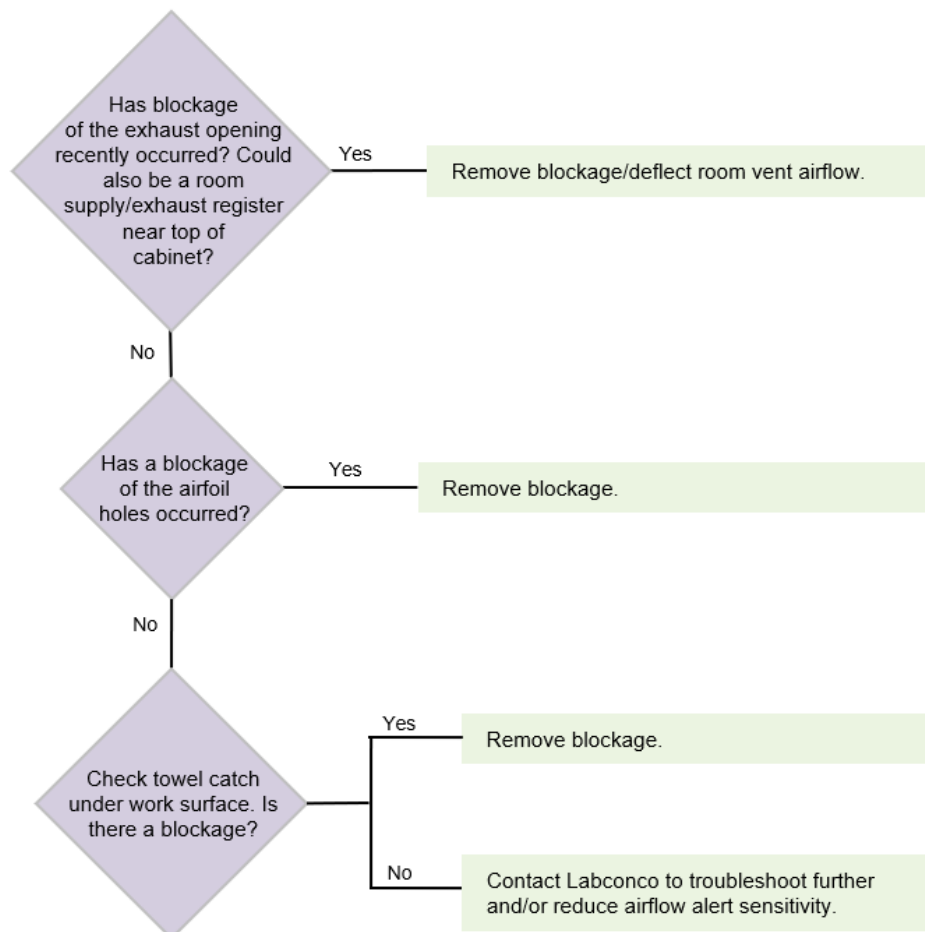
## Lights only will not illuminate



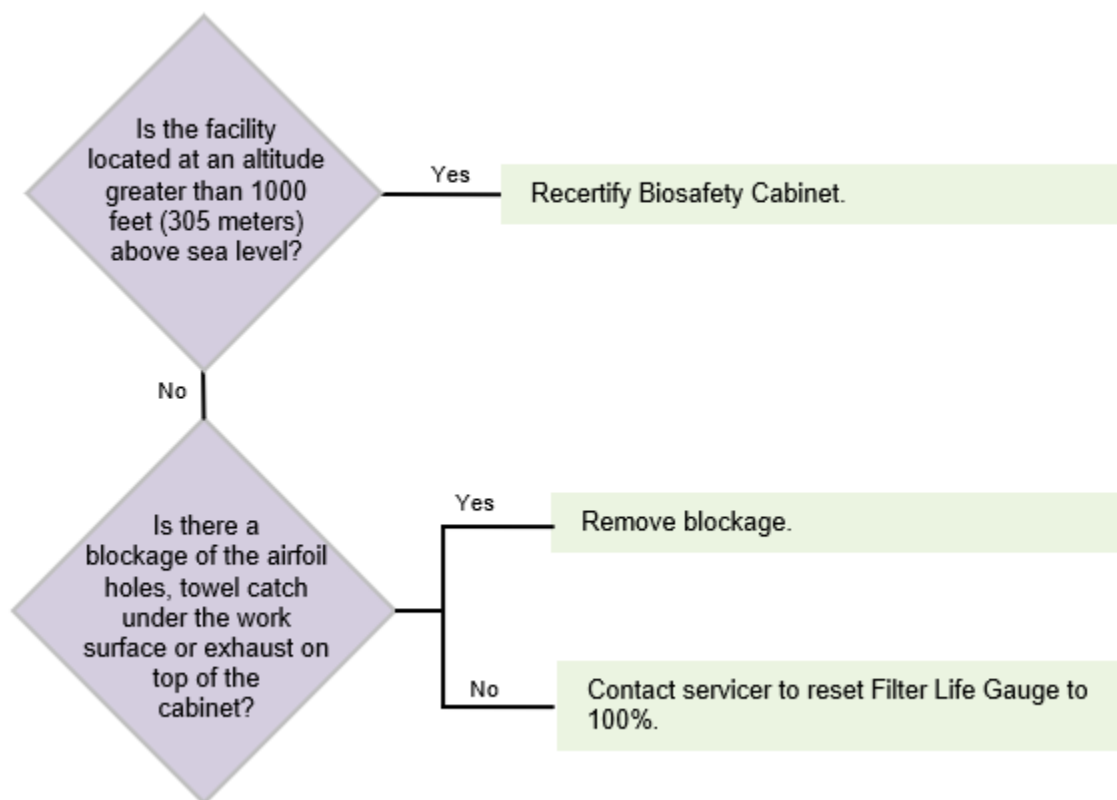
## UV Light will not illuminate



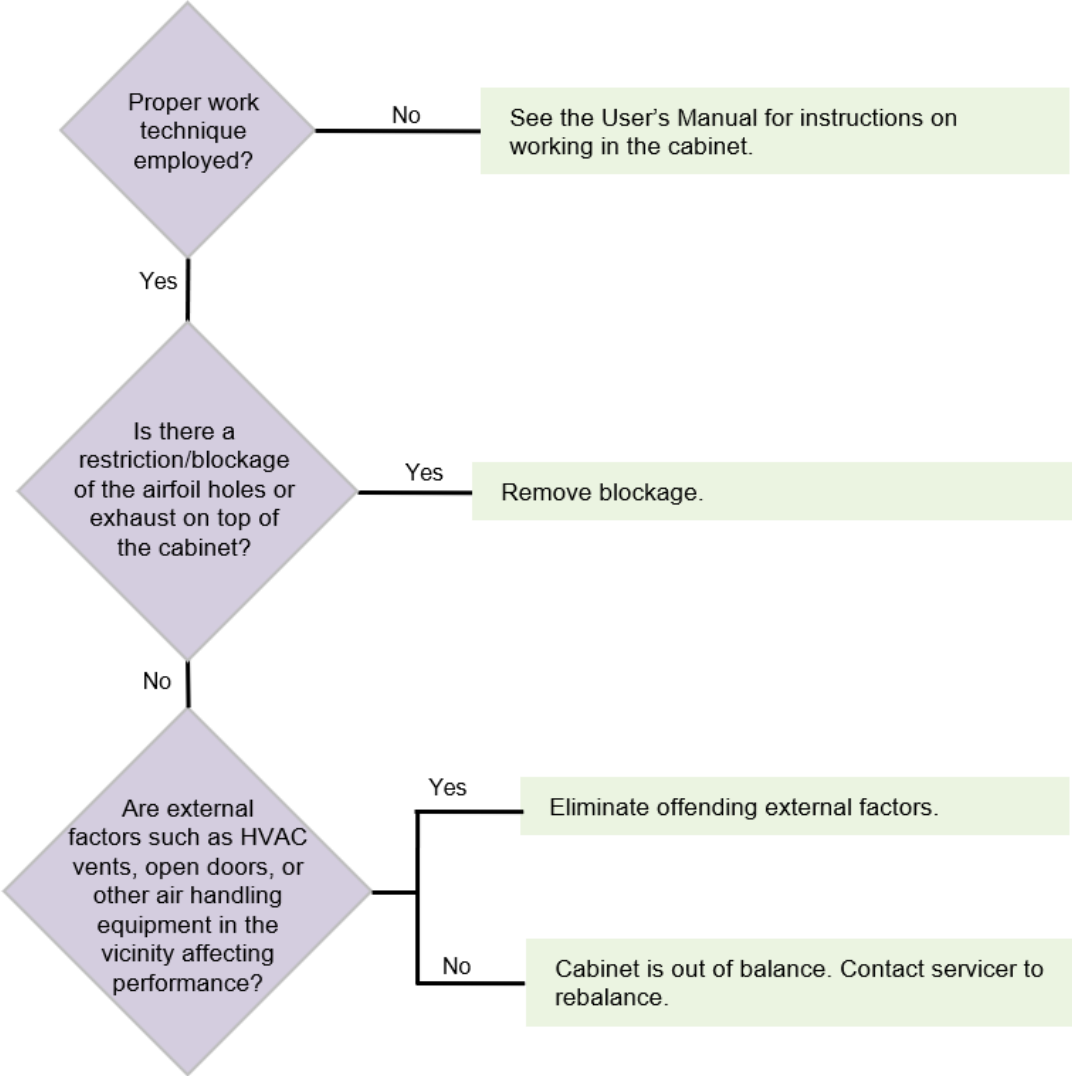
## Airflow Alert activating



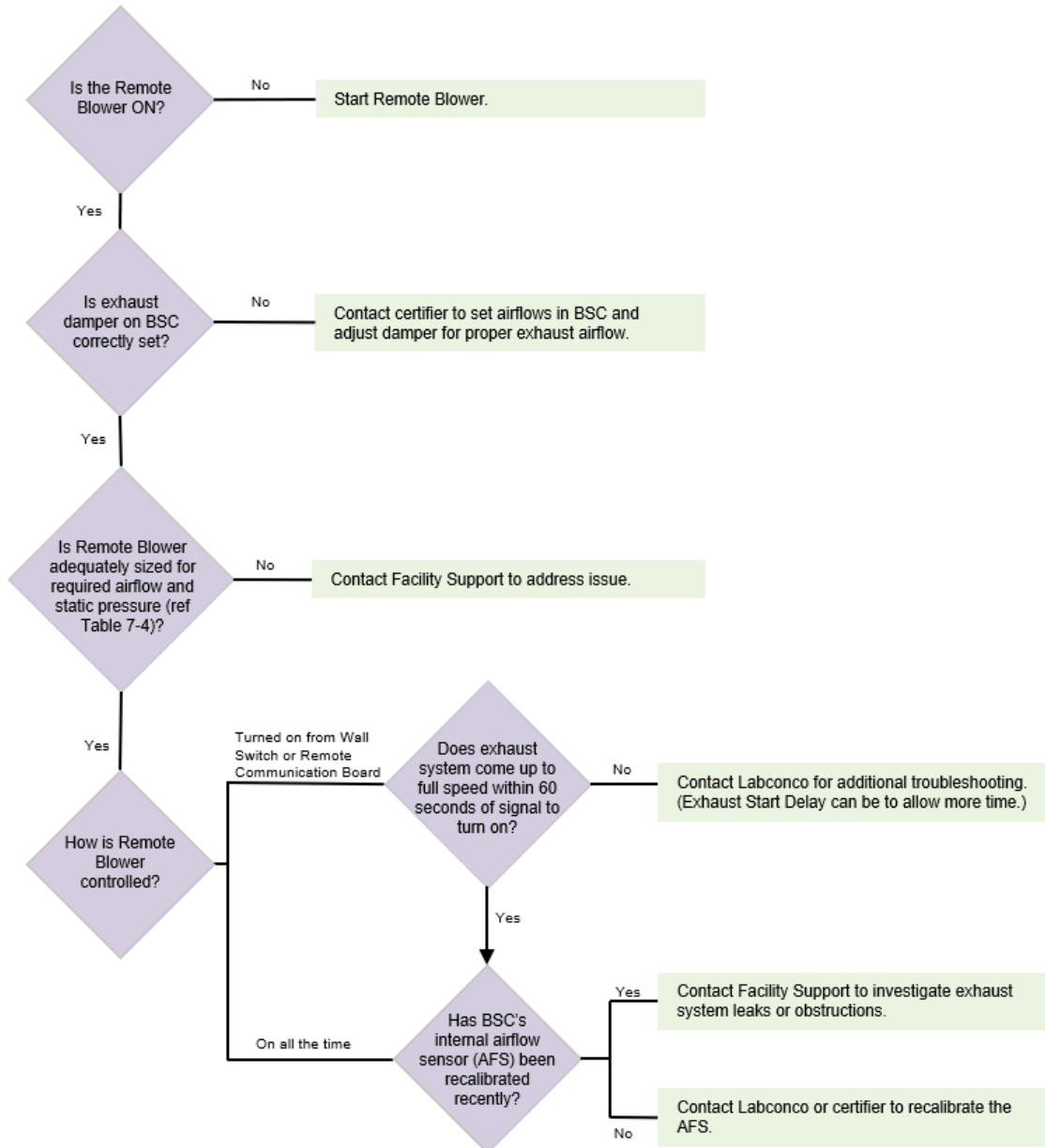
## Filter Life Status not at 100% when new



# Contamination in the work area



## (B2 Only) Exhaust Alarm activates 60 seconds after turning blower ON



## Advanced Troubleshooting

If the problem was not described in the previous troubleshooting guides in this section, or the guide did not resolve the problem, Labconco can provide additional assistance. To expedite resolution, please follow the instructions below to download information from the biosafety cabinet and email the following items to the Labconco product service representative assisting you.

- Serial Number (see section 4: *Serial Tag* for location).
- Picture(s) of the biosafety cabinet showing at least 12 inches (30 cm) around all sides of the biosafety cabinet.
- Download the data log covering the time in which any unexpected behavior occurred (see instructions below).
- Download the Diagnostics file providing status information (see instructions below).
- Download the Event History file providing a record of Alarms (see instructions below).
- Download the Logcat file providing additional debug information (see instructions below).

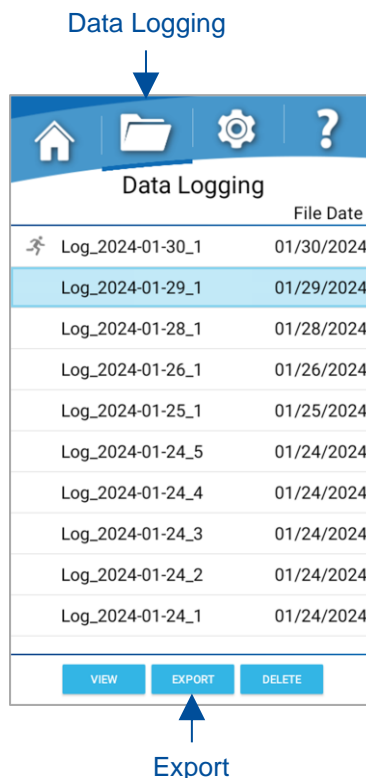


If at any time the software asks for the Thumbdrive to be removed and reinstalled, follow the instructions and remove/reinstall the Thumbdrive. Take care to insert the thumbdrive fully. Wait 5 or 6 seconds and then attempt to export the desired file by interacting with the touchscreen as described in the sections below. The extra time allows the operating system to recognize the drive and properly configure communications with it.

## Download a Data Log

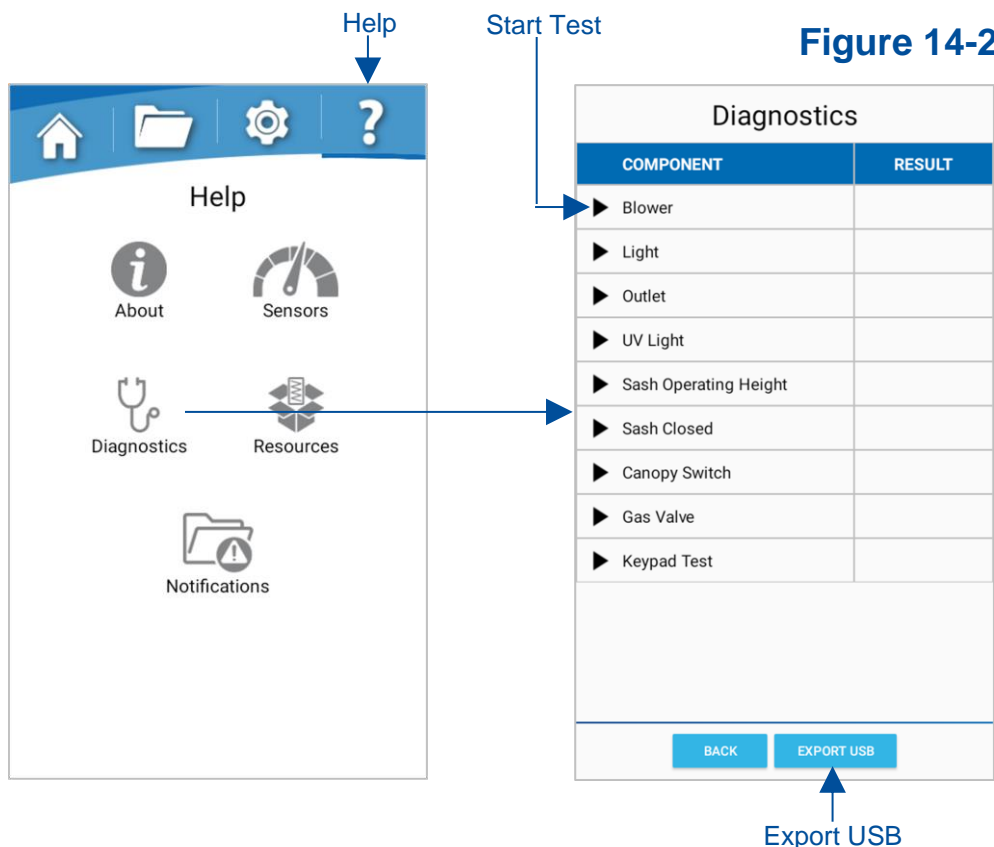
1. Format a thumbdrive properly as **FAT32**. If it is not, the product will not recognize the thumbdrive, and you will receive a pop-up instructing you that the drive is not properly formatted. If this occurs, you must reformat the thumbdrive using a PC or laptop to **FAT32**. For Windows users, you must select “**FAT32**” when formatting the thumbdrive, and not “**FAT32 (default)**”.
2. Insert the thumbdrive into the USB port located on the right corner post, beneath the keypad.
3. A pop-up will prompt you to allow the software to access the files on the thumbdrive. This is a security feature of the Android-based software. You must touch **[OK]** to continue. The loading screen stating, “please wait while USB flashdrive is loading” will auto-dismiss when complete.
4. Verify the product is set to allow touch on the display (if display does not respond to a touch to the main menu bar, press the **[Touch]** key on the keypad once and a green “Touch” image will flash on the display).
5. From the Home Screen, touch **[Data Logging]** as shown in Figure 14-1.
6. Touch the data log which includes the time which the unexpected behavior occurred (if unknown, touch the most recent data log). The data log should be highlighted blue now (as shown in Figure 14-1).
7. Touch the **[Export]** button at the bottom of the screen as shown in Figure 14-1.
8. When prompted, select “CSV” for the format of the data log and touch **[OK]**.
9. When the export process is complete you will receive a confirmation pop-up.

**Figure 14-1**



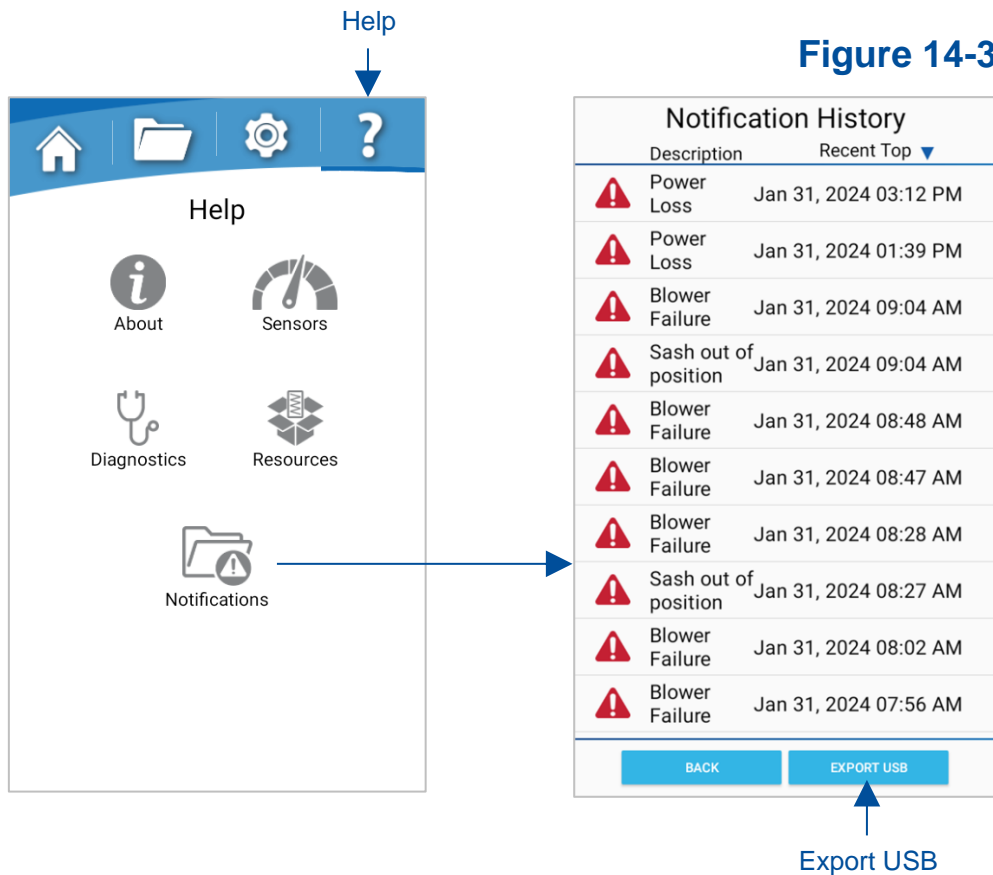
## Download a Diagnostics File

2. Format a thumbdrive properly as **FAT32**. If it is not, the product will not recognize the thumbdrive, and you will receive a pop-up instructing you that the drive is not properly formatted. If this occurs, you must reformat the thumbdrive using a PC or laptop to **FAT32**. For Windows users, you must select “**FAT32**” when formatting the thumbdrive, and not “**FAT32 (default)**”.
3. Insert the thumbdrive into the USB port located on the right corner post, beneath the keypad.
4. A pop-up will prompt you to allow the software to access the files on the thumbdrive. This is a security feature of the Android-based software. You must touch **[OK]** to continue. The loading screen stating, “please wait while USB flashdrive is loading” will auto-dismiss when complete.
5. Verify the product is set to allow touch on the display (if display does not respond to a touch to the main menu bar, press the **[Touch]** key on the keypad once and a green “Touch” image will flash on the display).
6. From the Home Screen, touch **[Help]** as shown in Figure 14-2.
7. From the Help Screen, touch **[Diagnostics]** as shown in Figure 14-2.  
All product functions **will be automatically stopped** when entering Diagnostics.
8. You have the option (but are not required) to run one or more Diagnostics tests by touching the **[Start Test]** icon by each component as shown in Figure 14-2.
9. Touch the **[Export USB]** button at the bottom of the screen (Figure 14-2).
10. When the export process is complete you will receive a confirmation pop-up.



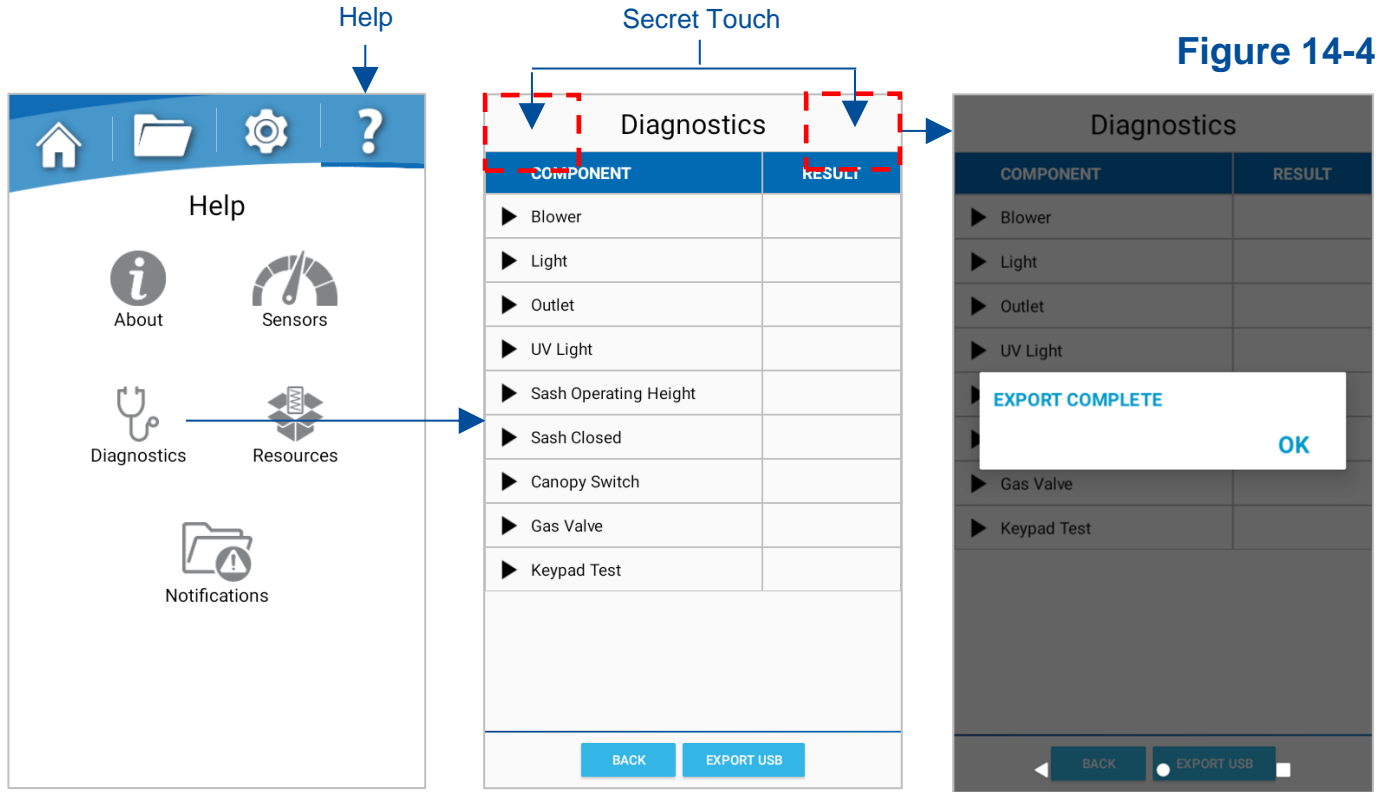
## Download an Event History File

1. Format a thumbdrive properly as **FAT32**. If it is not, the product will not recognize the thumbdrive, and you will receive a pop-up instructing you that the drive is not properly formatted. If this occurs, you must reformat the thumbdrive using a PC or laptop to **FAT32**. For Windows users, you must select “**FAT32**” when formatting the thumbdrive, and not “**FAT32 (default)**”.
2. Insert the thumbdrive into the USB port located on the right corner post, beneath the keypad.
3. A pop-up will prompt you to allow the software to access the files on the thumbdrive. This is a security feature of the Android-based software. You must touch **[OK]** to continue. The loading screen stating, “please wait while USB flashdrive is loading” will auto-dismiss when complete.
4. Verify the product is set to allow touch on the display (if display does not respond to a touch to the main menu bar, press the **[Touch]** key on the keypad once and a green “Touch” image will flash on the display).
5. From the Home Screen, touch **[Help]** as shown in Figure 14-3.
6. From the Help Screen, touch **[Notifications]** as shown in Figure 14-3.
7. Touch the **[Export USB]** button at the bottom of the screen (Figure 14-3).
8. When the export process is complete you will receive a confirmation pop-up.



## Download a Logcat File

1. Format a thumbdrive properly as **FAT32**. If it is not, the product will not recognize the thumbdrive, and you will receive a pop-up instructing you that the drive is not properly formatted. If this occurs, you must reformat the thumbdrive using a PC or laptop to **FAT32**. For Windows users, you must select “**FAT32**” when formatting the thumbdrive, and not “**FAT32 (default)**”.
2. Insert the thumbdrive into the USB port located on the right corner post, beneath the keypad.
3. A pop-up will prompt you to allow the software to access the files on the thumbdrive. This is a security feature of the Android-based software. You must touch **[OK]** to continue. The loading screen stating, “please wait while USB flashdrive is loading” will auto-dismiss when complete.
4. Verify the product is set to allow touch on the display (if display does not respond to a touch to the main menu bar, press the **[Touch]** key on the keypad once and a green “Touch” image will flash on the display).
5. From the Home Screen, touch **[Help]** as shown in Figure 14-4.
6. From the Help Screen, touch **[Diagnostics]** as shown in Figure 14-4.
7. Simultaneously touch the top right and left corners of the display (see **Secret Touch** shown in Figure 14-4). Hold this touch for approximately 5 seconds.
8. When the export process is complete you will receive a confirmation pop-up. Touch **[OK]**. The thumbdrive can be removed at this time.



## Email Files to Product Service

1. Using a computer, insert the thumbdrive with the file(s) downloaded from the product, and open a file browser to view the files. A folder was created on the thumbdrive called “Labconco” as shown in Figure 14-5. Open this folder.

Figure 14-5

Name	Date modified	Type	Size
Labconco	4/25/2024 11:55 AM	File folder	
LOST.DIR	4/18/2024 3:43 PM	File folder	

2. Depending on which file(s) were exported, one or more files will be found inside the “Labconco” folder (Figure 14-6). If file(s) were exported from multiple products, each file is named with the product’s Serial Number (see [Serial Number Suffix](#) below), so it can be located easily.

### Serial Number Suffix

Figure 14-6

Name	Date modified	Type	Size
alert-history-123456789	4/25/2024 11:58 AM	JSON File	9 KB
certification-records-123456789	4/25/2024 11:58 AM	JSON File	1 KB
diagnostics-123456789	4/25/2024 11:58 AM	Text Document	1 KB
Labconco_Logs_123456789_0	4/25/2024 11:58 AM	Compressed (zipp...	4,399 KB
Log_2024_04_22_3_123456789	4/25/2024 11:55 AM	Microsoft Excel C...	1 KB
maintenance-123456789	4/25/2024 11:58 AM	JSON File	1 KB

3. Attach all of the relevant files to the email to the product service representative helping you. The file size is generally very small (less than 10 KB); however the “Labconco Logs” zip file may be up to 5 to 10 MB. Verify your email provider can send files of this size before sending the email.



## Blower

Note: All 8-foot Type A2 models have two (2) blowers. If diagnosing an 8-foot A2, repeat the steps below on each blower as needed.

1. In the *Diagnostics Screen*, locate and touch the **[▶]** beside *Blower*.
2. Confirm you want to start the test by touching **[OK]**.
3. Test will run. If no failures are detected, the *Result* column next to *Blower* will read 'Passed'.

## Light

1. In the *Diagnostics Screen*, locate and touch the **[▶]** beside *Light*.
2. Confirm you want to start the test by touching **[OK]**.
3. Test will run. If the Light(s) illuminated, touch **[Yes]**.
4. If successful, the *Result* column next to *Light* will read 'Passed'.

## Outlet

1. In the *Diagnostics Screen*, locate and touch the **[▶]** beside *Outlet*.
2. Confirm you want to start the test by touching **[OK]**.
3. Test will run. If the outlet(s) powered, touch **[Yes]**.
4. If successful, the *Result* column next to *Outlet* will read 'Passed'.

## UV Light

1. In the *Diagnostics Screen*, locate and touch the **[▶]** beside *UV Light*.
2. Confirm you want to start the test by touching **[OK]**.
3. If not already, close the sash. UV Lights will not illuminate with the sash out of closed position.
4. Test will run. If the UV Light(s) illuminated, touch **[Yes]**.
5. If successful, the *Result* column next to *UV Light* will read 'Passed'.

## Sash Sensors

1. In the *Diagnostics Screen*, locate and touch the **[▶]** beside *Sash Operating Height*.
    - a. Confirm you want to start the test by touching **[OK]**.
    - b. If not already, open the sash to *Full Open* position when prompted.
    - c. Adjust the sash to Operating Height when prompted.
    - d. If successfully done, the Result column next to *Sash Operating Height* will read 'Passed'.
  
  2. Locate and touch the **[▶]** beside *Sash Closed*.
    - a. Confirm you want to start the test by touching **[OK]**.
    - b. If not already, open the sash to *Full Open* position when prompted.
    - c. Lower the sash to the *Sash Closed* position when prompted. Note: if the unit has a microscope sash cutout/frame, the closure switch may need to be manually actuated.
    - d. If successfully done, the *Result* column next to *Sash Closed* will read 'Passed'.
  
  3. If applicable, locate and touch the **[▶]** beside *Sash Almost Closed*.
    - a. Confirm you want to start the test by touching **[OK]**.
    - b. If not already, open the sash to *Full Open* position when prompted.
    - c. Lower the sash to the *Sash Almost Closed* position, approximately ½-inch (12mm) from the fully closed position, when prompted.
    - d. If successfully done, the *Result* column next to *Sash Closed* will read 'Passed'.
-

## Canopy (Optional)

1. In the *Diagnostics Screen*, locate and touch the **[▶]** beside *Canopy Switch*.
2. Confirm you want to start the test by touching **[OK]**.
3. Follow the instructions on the prompt to close the inlet valve (flap on right end of Canopy) for 3 seconds, and then open again.
4. Test will run. If successful, the Result column next to *Canopy Switch* will read 'Passed'.
5. If testing an 8-foot Type A2 model with two canopies installed, repeat steps 1 through 4 on the second canopy.

## Gas Valve (Optional)

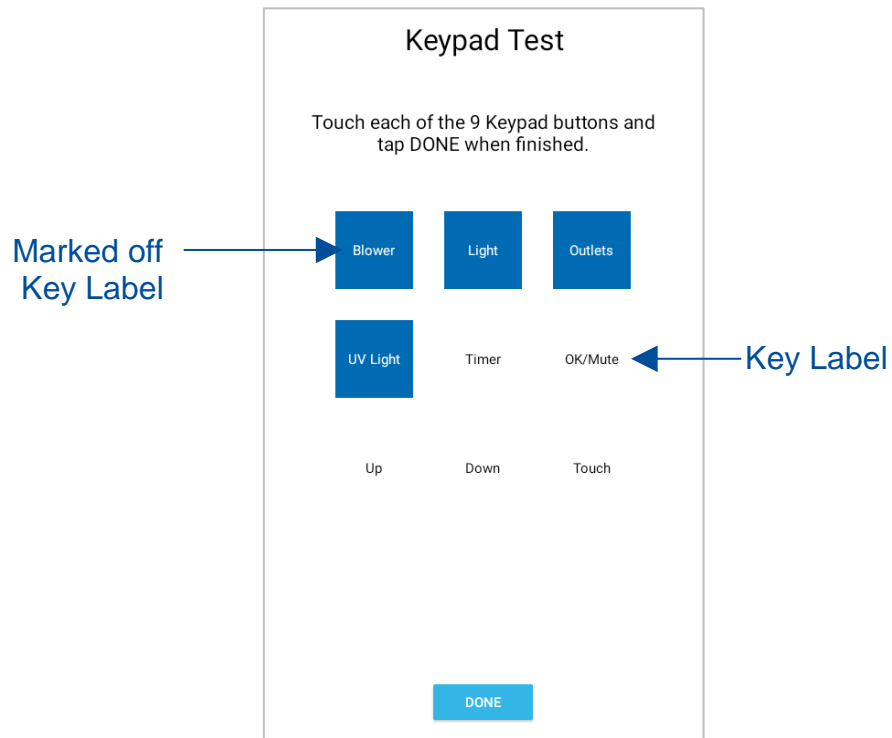
1. In the *Diagnostics Screen*, locate and touch the **[▶]** beside *Gas Valve*.
2. Confirm you want to start the test by touching **[OK]**.
3. Test will run. If the gas valve turned on gas allowed to flow and back off, touch **[Yes]**.
4. If successful, the *Result* column next to *Gas Valve* will read 'Passed'.

## Keypad

1. In the *Diagnostics Screen*, locate and touch the **[▶]** beside *Keypad*.
2. Confirm you want to start the test by touching **[OK]**.
3. Press each of the 9 keypad buttons and confirm the label on the display is marked off with the corresponding key press. Reference Figure 15-2.
  - a. Press **[Blower]**. The display will show the Blower in blue.
  - b. Press **[Light]**. The display will show the Light in blue.
  - c. Press **[Outlet]**. The display will show the Outlet in blue.
  - d. Press **[UV Light]**. The display will show the UV light in blue.
  - e. Press **[Timer]**. The display will show the Timer in blue.
  - f. Press **[OK/Mute]**. The display will show the OK/Mute in blue.

- g. Press [▲]. The display will show the Up button in blue.
  - h. Press [▼]. The display will show the Down in blue.
  - i. Press [Touch]. The display will show the Touch in blue.
4. Touch [Done] when complete. If successful, the *Result* column next to *Keypad* will read 'Passed'.

**Figure 15-2**

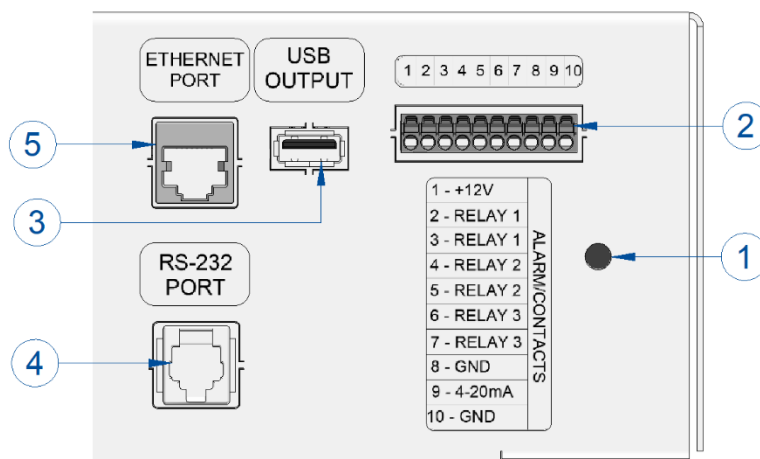


## 16: Remote Communication Kit

All biosafety cabinets are prepared with the necessary wiring/mating components to accept a Remote Communication Board (RCB) Kit (Catalog Number 3289000). The RCB is standard on all Type B2 cabinets. This kit provides the following functions (reference Figure 16-1):

1. An audible alarm upon power loss per EN12469:2000 for microbiological safety cabinets (primarily required in Europe).
2. A set of 3 relay contacts, which close upon three cabinet conditions:
  - Blower start is desired, and blower running
  - Blower enters reduced setback speed (Night-Smart with sash closed)
  - Any alarm condition
3. USB Data Output
4. RS-232 Data Output
5. Ethernet Pass-Thru

Figure 16-1



### Installation

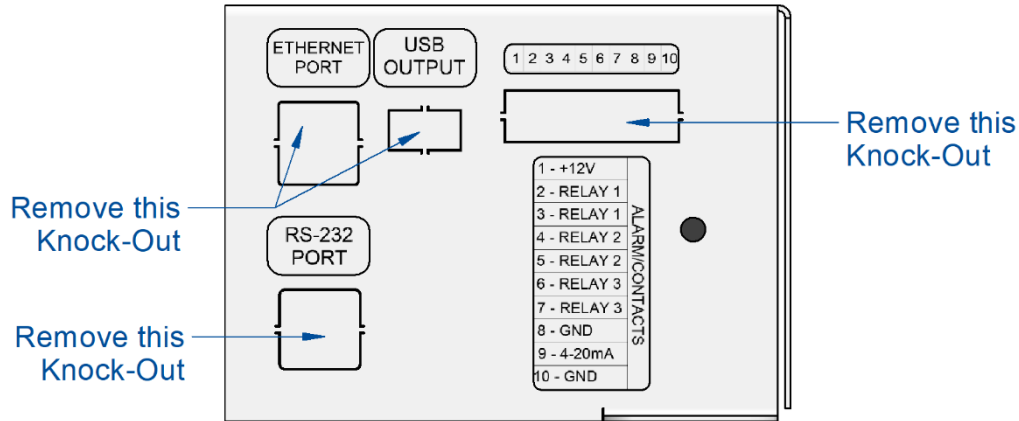
A qualified electrician or certifier should install this kit.

1. Disconnect all electrical power to the biosafety cabinet by unplugging the power cord.
2. If cabinet has an exhaust cover, remove the two phillips screws on the front face of the cover. If two exhaust covers are present, only work on the Lift the front edge of the cover up to fully remove or use the prop as needed. For more detailed instructions, see [Removal of External Dress Panels: Exhaust Cover](#) in [Section 12: Advanced Service Procedures](#).
3. Using a 7/16-inch socket or nut driver, remove the four nuts that secure the electronics module to the top, right side of the biosafety cabinet.



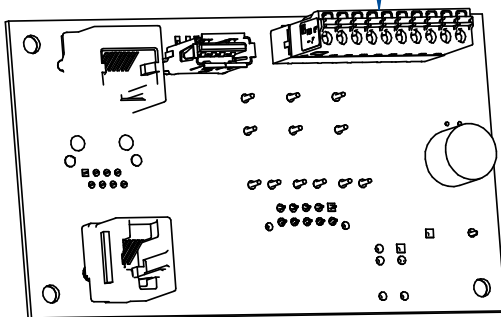
4. Tilt the electronics module on its side, and secure the module.
5. Carefully remove the rectangular knock-outs on the left side of the electronics module when normally positioned atop the biosafety cabinet. The knock-outs to remove are shown in Figure 16-2.

**Figure 16-2**

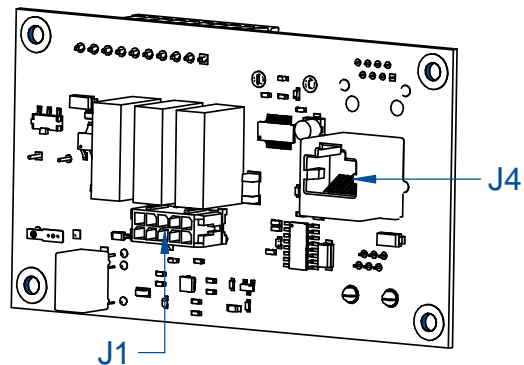


6. Locate and remove the 10-pin connector (see Figure 16-3) on the RCB supplied with the kit. This connector shows through one of the knock-outs previously removed on the electronics control module. Note: the removed connector will be reinstalled after the RCB is secured in the control module.

**Figure 16-3**



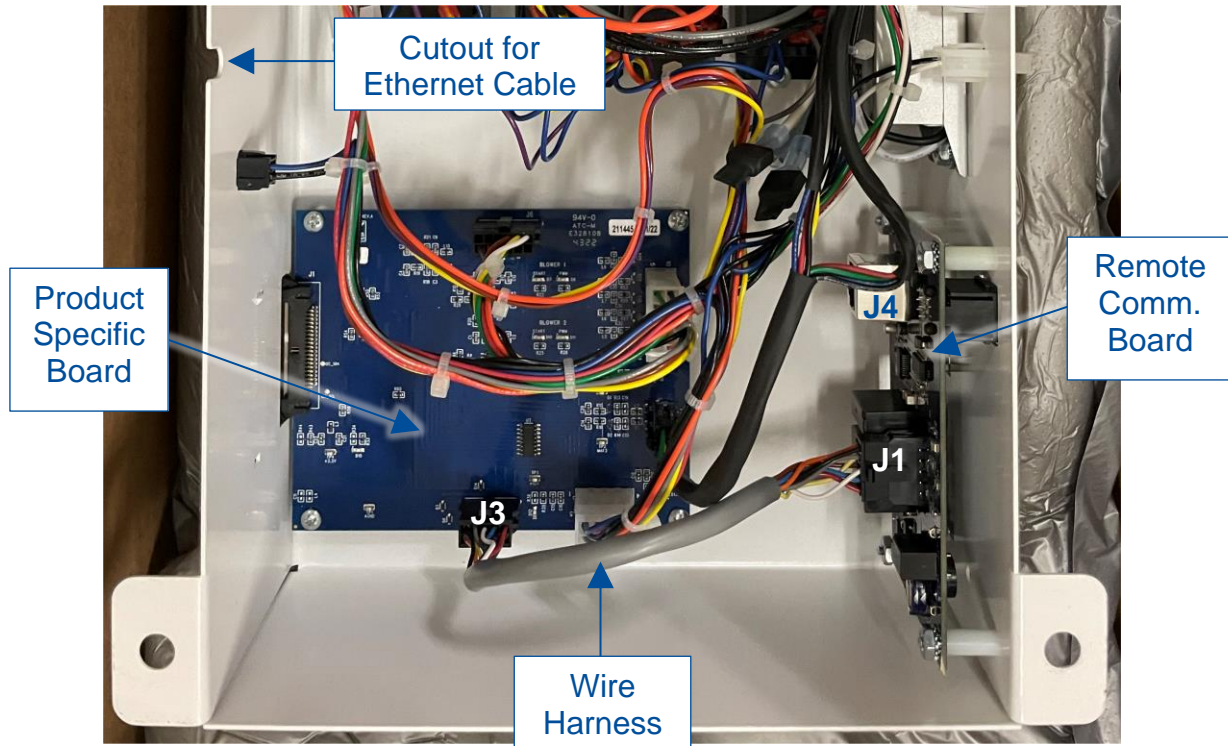
**Figure 16-4**



7. Install the RCB inside the electronics module using the screws, included with the kit. First, line up the holes of the board with the threaded standoffs inside the module. Make sure the RCB is oriented so the connectors (visible in Figure 16-3) sit within the knock-out openings from Step 5. Then secure in place by installing the four phillips screws.

8. Locate the wire harness included in the kit. Connect it between the RCB J1 connector and the Product Specific Board's J3 connector. See Figure 16-5 for reference.

**Figure 16-5**



9. Locate the Ethernet Cable in the kit. Install one end of the ethernet cable into J4 (the RCB's ethernet port on the inside of the electronics module, see Figure 16-5). Route the other end of the cable safely out of the module box via the cutout provided (reference Figure 16-5).
10. Open the right-Side Panel by removing the two phillips head screws and hinging the panel open. For more detailed instructions, see *Removal of External Dress Panels: Side Panels* in [Section 12: Advanced Service Procedures](#).
11. Locate the ethernet port of the Display Board. Insert the other end of the ethernet cable into the port. Adjust the cable as needed to reinstall the Side Panel without pinching the cable. Close the Side Panel and secure with the previously removed phillips screws.
12. Re-secure the electronics module to the top of the biosafety cabinet. If needed, reinstall the exhaust cover.



*If connecting the RCB's 4-20mA signals with an external blower (Labconco's Spectrum Blower) on a B2 or C1 unit, see your Spectrum's User Manual for more information.*

If not utilizing the Relay Contacts, stop here.

13. Connect user-supplied wires to the appropriate contacts as desired. **Use 22-24 AWG wires ONLY.** Strip insulation back from wire end 0.25 inches (6 mm).
14. Using a small jeweler's flat blade screwdriver or similar instrument, press the screwdriver into the groove of the push button (see Figure 16-6) to compress the button. This will open the contact clamp. Slide the stripped wire end into the appropriate slot on the connector, then remove the screwdriver. If easier, the terminal block can be removed and reinstalled from the RCB via J2 (see Figure 16-6). To release a wire, press and compress the groove of the push button with a screwdriver and pull the wire straight out from the connector. See Figure 16-6 for reference.

**Figure 16-6**



The relay contact closes when the condition is present on the biosafety cabinet. See the pinout configuration below in Table 16-1 to properly connect the wires.

**Table 16-1**

Position	Contact Label	Condition/Description
1	+12 VDC	+12 VDC supplied
2	RELAY 1	Blower ON & over 300 rpm = Closed (Blower OFF or Night-Smart = Open)
3	RELAY 1	
4	RELAY 2	Blower in Night-Smart mode = Closed (Blower ON/OFF/WAIT/Alarm = Open)
5	RELAY 2	
6	RELAY 3	Any Alarm Condition Active = Closed (No Alarm Active = Open)
7	RELAY 3	
8	GND	Commonly used with +12 VDC
9	4-20mA	Variable 4-20mA supplied to remote blower
10	GND	Use with 4-20mA



**CAUTION:** The provided contacts can only switch very low amounts of electrical current. To control high current, such as AC line-operated devices, the provided contacts must be used to

control yet another set of contacts (i.e. relay) that are rated for the actual load being switched (see examples below).

### Example 1 – Blower Relay Contact (Single Phase AC)

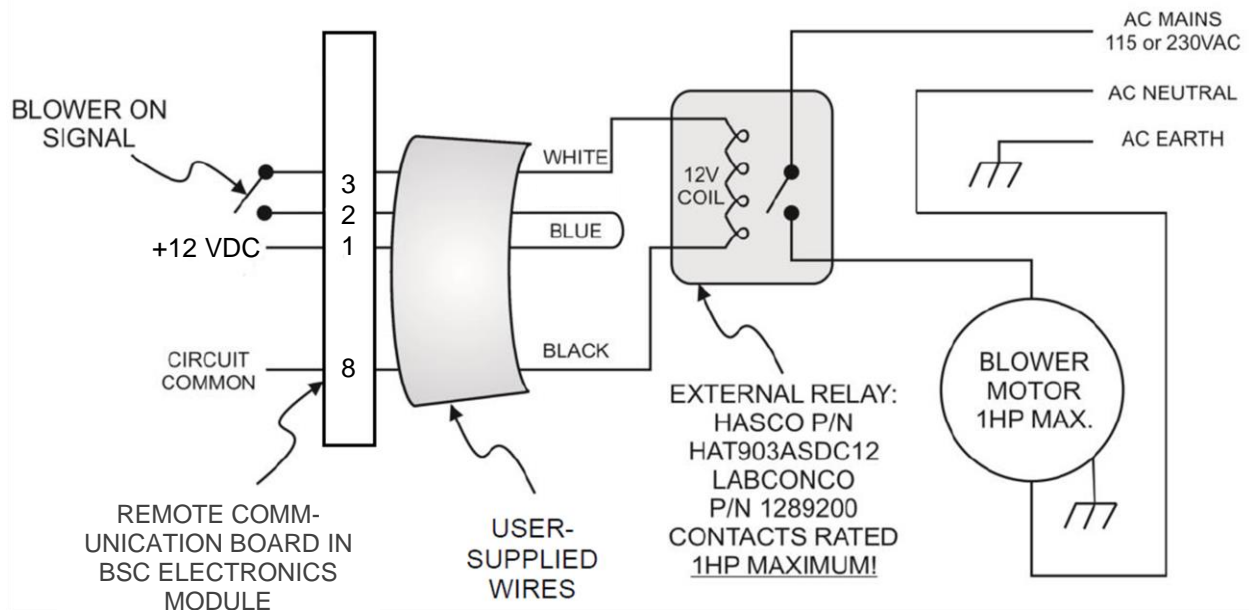
The Blower set of contacts (Relay 1, pins 2 & 3) will indicate when the cabinet's blower is on. For Type B2 cabinets, the Blower set of contacts (Relay 1, pins 2 & 3) will indicate when the Exhaust Blower is desired ON. On Type A2 cabinets, this contact will close once the blower key is pressed on the cabinet's keypad, and remain closed while the blower is at Normal Speed.

However, on a B2 cabinet, the contacts will close when the blower key is pressed to signal (through this Relay 1 contact) a remote exhaust blower to start. The cabinet's blower will NOT start until the internal Airflow Sensor verifies proper exhaust airflow from the remote exhaust blower. Once the cabinet's blower successfully starts, the contact will remain closed.

The generalized circuit shown below indicates how to interface the cabinet's provided contacts to power a single phase high current device (like a remote exhaust blower).

**Note: The cabinet's provided contacts are used to actuate the low-power coil of a user-supplied external power relay/contacter. Never run high current or AC voltage through the cabinet's provided contacts!**

The relay in the example below is: Hasco HAT903ASDC12 (Labconco P/N 1289200), the 12V coil draws only .08 Amps (choose a relay with an amp draw for the actuator coil less than 0.5 A) ***If using two or three of the provided relay contacts, the sum total of all current draw from three relay actuator coils must be less than 0.5A.***



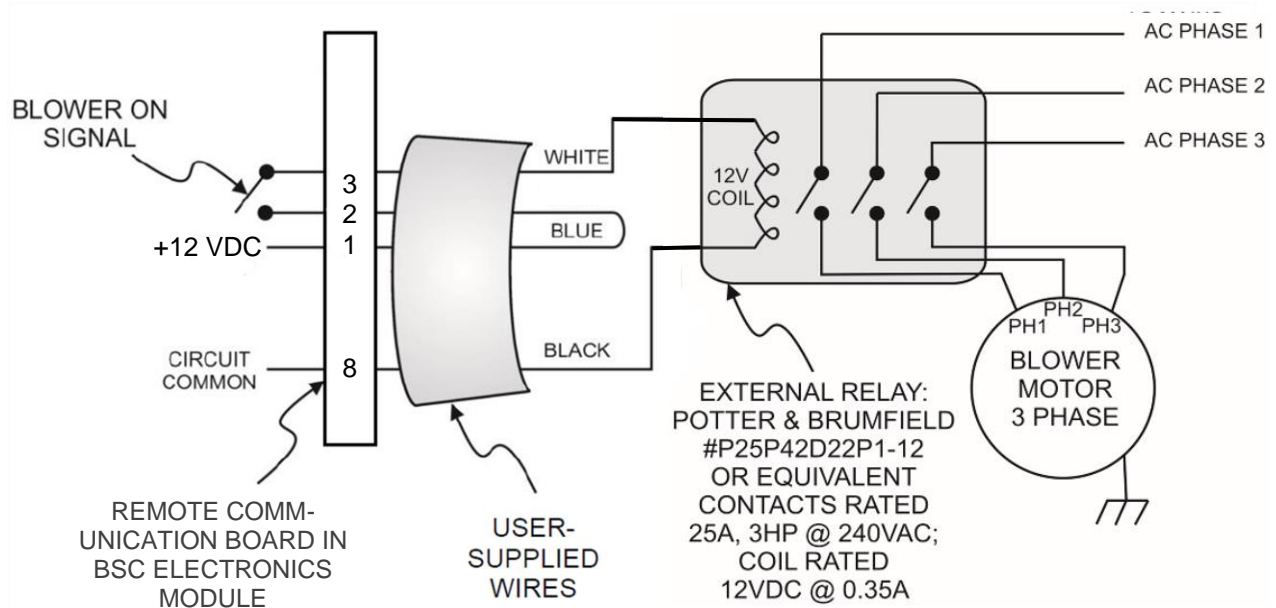
## Example 2 – Blower Relay Contact (Three Phase AC)

The Blower set of contacts (Relay 1, pins 2 & 3) will indicate when the cabinet's blower is on. For Type B2 cabinets, the Blower set of contacts (Relay 1, pins 2 & 3) will indicate when the Exhaust Blower is desired ON. On Type A2 cabinets, this contact will close once the blower key is pressed on the cabinet's keypad, and remain closed while the blower is at Normal Speed.

However, on a B2 cabinet, the contacts will close when the blower key is pressed to signal (through this Relay 1 contact) a remote exhaust blower to start. The cabinet's blower will NOT start until the internal Airflow Sensor verifies proper exhaust airflow from the remote exhaust blower. Once the cabinet's blower successfully starts, the contact will remain closed.

The generalized circuit shown below indicates how to interface the cabinet's provided contacts to power a Three Phase high current device (like a remote exhaust blower). **Note that the cabinet's provided contacts are used to actuate the low-power coil of a user-supplied external power relay/contacter. Never run high current or AC voltage through the cabinet's provided contacts!**

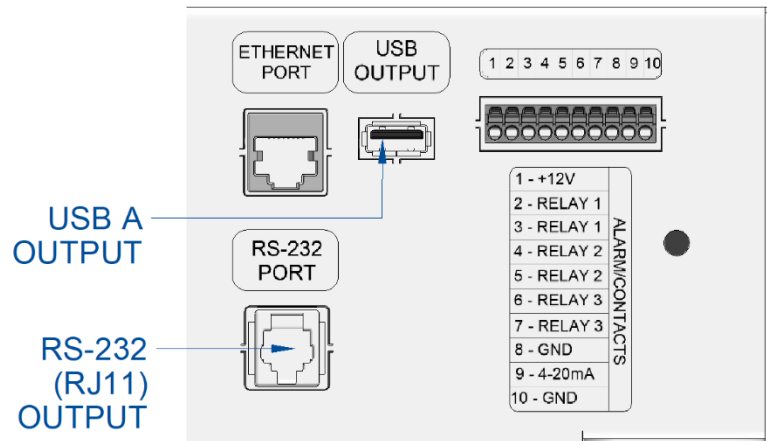
The relay in the example below is: Potter & Brumfield P25P42D22P1-12, the 12V coil draws .35 Amps (the provided +12VDC is fused at 0.5 Amps total, so choose a relay with an amp draw for the actuator coil less than 0.5 A). ***If using all three provided relay contacts, the sum total of all current draw from three relay actuator coils must be less than 0.5A.***



## BMS Data Output

The operation of the Biosafety Cabinet can be monitored using a computer connected to the Remote Communication Board (RCB) installed in the electronics module on top of the cabinet. The data output ports available are an RS-232 and USB as shown in Figure 16-7. The remotely connected computer can monitor the cabinet, but not control the cabinet.

**Figure 16-7**



## Connection Type

Two styles of connection types are provided for flexibility. The data transmitted from each connection are the same.

**Figure 16-8**

To connect to the USB port, a **USB A** connector is required (see Figure 16-8).



**Note:** The USB A port on the RCB does not supply power, it only transmits data.



**Figure 16-9**

To connect to the RS-232 port, an **RJ11** connector is required (see Figure 16-9).



## Data Output Format

To correctly receive data output from the Logic cabinet, set the following communication configurations on the receiving computer:

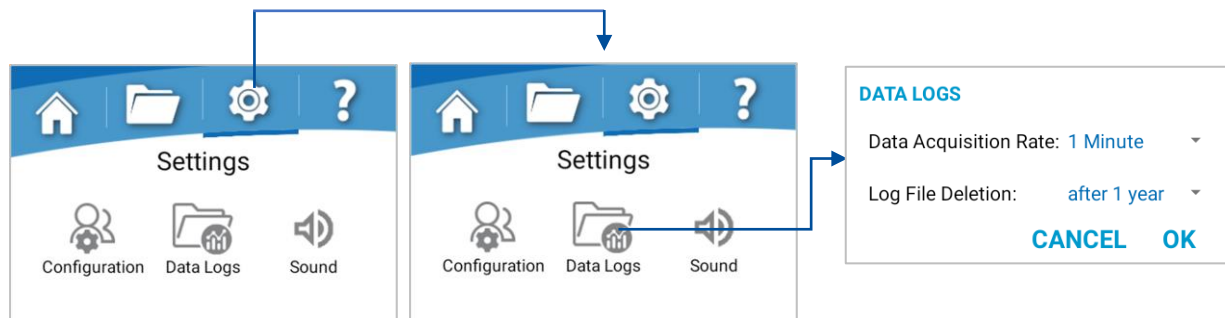
- Data (Baud) Rate = 9600 Baud
- Word Length = 8-Bit
- 1 Start Bit, 1 Stop Bit
- No parity is transmitted
- Standard ASCII character set

## Data Output Rate

Status data is broadcast whether a recipient is receiving or not. The rate at which status data is broadcast is variable through the *Settings Screen* and matches the rate used for the *Data Logs Menu*. To access this screen, follow these steps:

1. From the *Home Screen*, touch **[Settings]** (represented by the gear-icon) on the Menu Bar of the display.
2. Touch **[Data Logs]**.

**Figure 16-10**

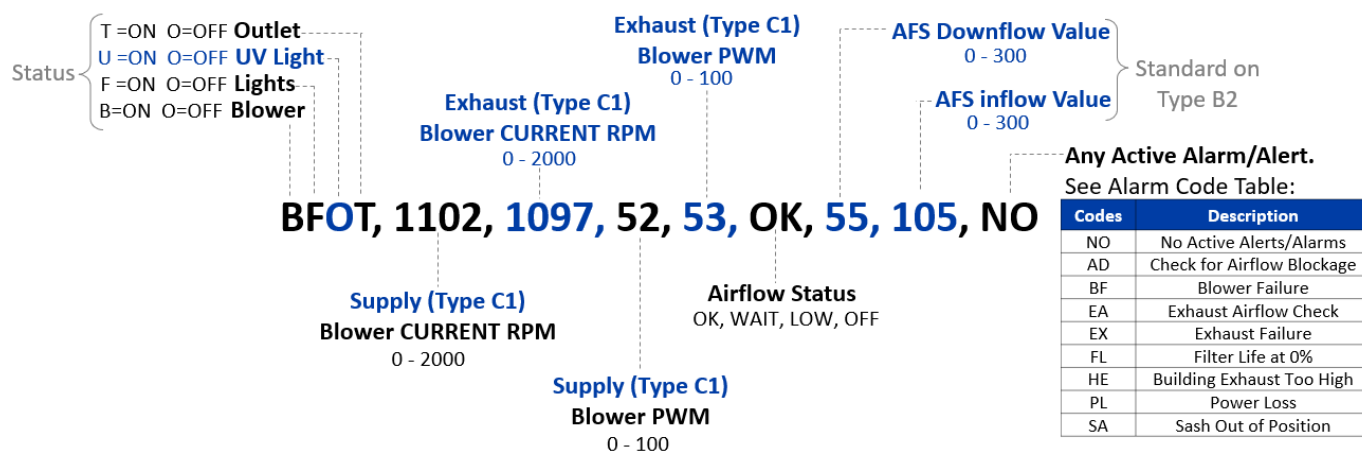


3. Touch the drop down arrow [▼] and scroll through the available options. To select the desired rate, touch the desired rate. It will be written in blue as shown in Figure 16-10. *Data Acquisition Rate* (Output Rate) options are once every:
  - 10 seconds
  - 30 seconds
  - 1 minute
  - 2 minutes
  - 3 minutes
  - 5 minutes
  - 10 minutes
4. To save your selection, touch **[Save]**.

## Data Output String Definition

The data string is limited to 80 characters, including spaces and commas. Use Figure 16-11 to understand the character significance. Characters in **Black Text** are standard for all cabinets. Characters in **Blue Text** are optional or cabinet type dependent and may not appear. Below each character explanation is the value range.

Figure 16-11



## Data Output Software Requirements

There are several commercially available software packages, which can read RS232-type data and enter the data into a computer program such as a word processor (to create a text file) or spreadsheet (to tabulate and plot the data). Consult your laboratory supply dealer regarding the latest software available.

## 17: Ventus II™ Canopy Connection Kit

To remote exhaust connect any Type A2 biosafety cabinet, the Ventus II canopy connection kit must be utilized. The Ventus II canopy system consists of a high efficiency, low profile canopy that interfaces directly with the Logic's control board. Ventus offers several features that are a distinct improvement over prior canopy designs:

- The alarm system is simple, rugged, and durable; a magnetic reed switch located on the inlet valve. The intake valve is also referred to as the inlet relief valve.
- The intake valve is angled such that the incoming make-up (room) air must keep the valve open to maintain normal operation; a loss of exhaust volume will allow gravity to close the intake valve and open the magnetic switch, resulting in a canopy alarm.
- During a canopy alarm, in addition to the audible and visual alarms, relief valves in the canopy will open, and the control board will adjust the Logic's blower speed to maintain safe airflow. These coordinated actions will help to maintain a safe inflow to protect the operator during the alarm.

Figure 17-1

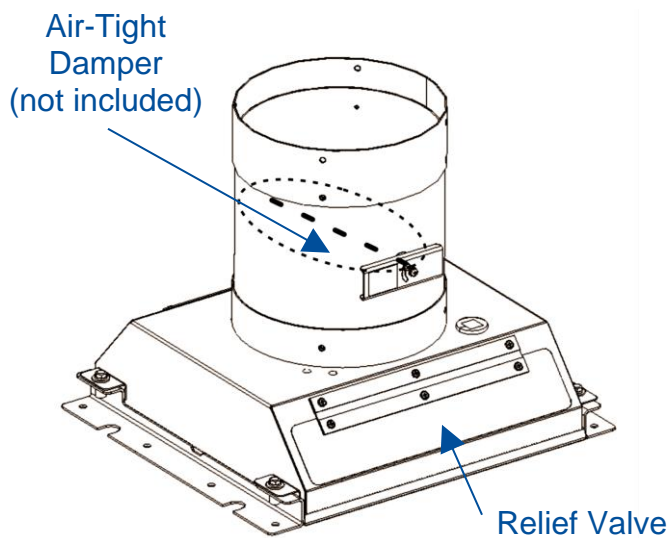
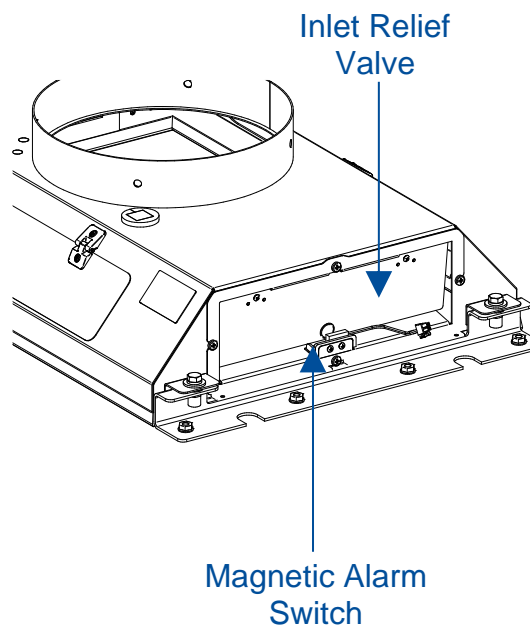


Figure 17-2



## Kit Catalog Numbers

**Table 17-1**

Cabinet Width (Feet)	Catalog Number
3-ft	3889210
4-ft	3889211
5-ft	3889212
6-ft	3889213
8-ft	3889214

### Installation Procedure

**NOTE:** Before beginning this installation, record the blower RPM(s) by following the steps below:



1. Turn the blower(s) on, touch **[Help]** (represented by the question mark icon) on the Menu Bar of the display. To enter the *Sensors Screen*, locate and touch **[Sensors]**.
2. Locate the row(s) of sensor data titled *Blower*.  
NOTE: 8-ft Type A2 models, there will be two blower readings: Left and Right.  
NOTE: Type C1 models, there will be two blower readings: supply and exhaust.
3. Record the motor(s) average RPMs once the unit operation stabilizes. NOTE: Type C1 models will have two different (supply and exhaust) motor RPMs to record.
4. Touch **[Back]** to exit the *Sensors Screen*.



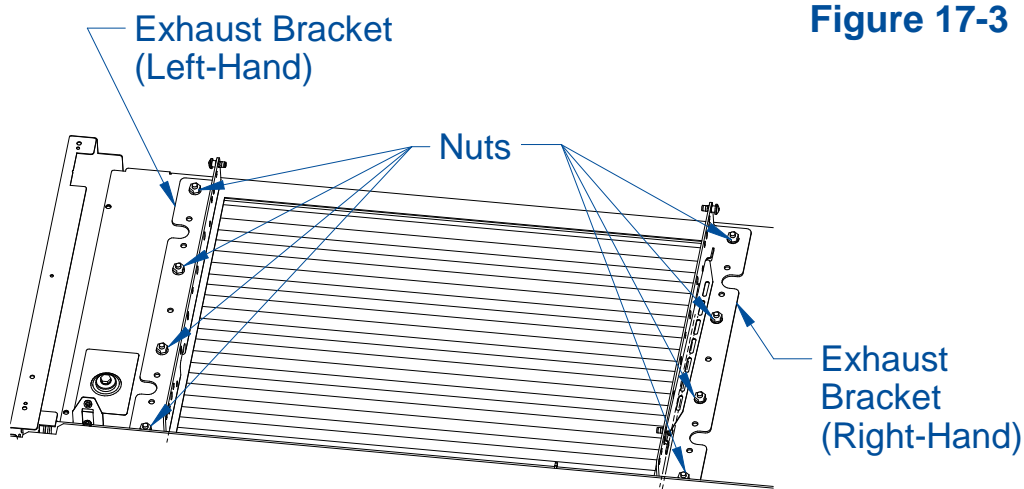
Exercise caution when removing or installing the exhaust filter cover, to prevent damaging the Exhaust HEPA filter.



It is recommended to utilize at least two (2) persons to remove the exhaust cover, particularly for a 5-ft or 6-ft model. The exhaust cover is heavy. Take care to use safe lifting practices, and to set the panel where it cannot fall over while uninstalled from the cabinet.

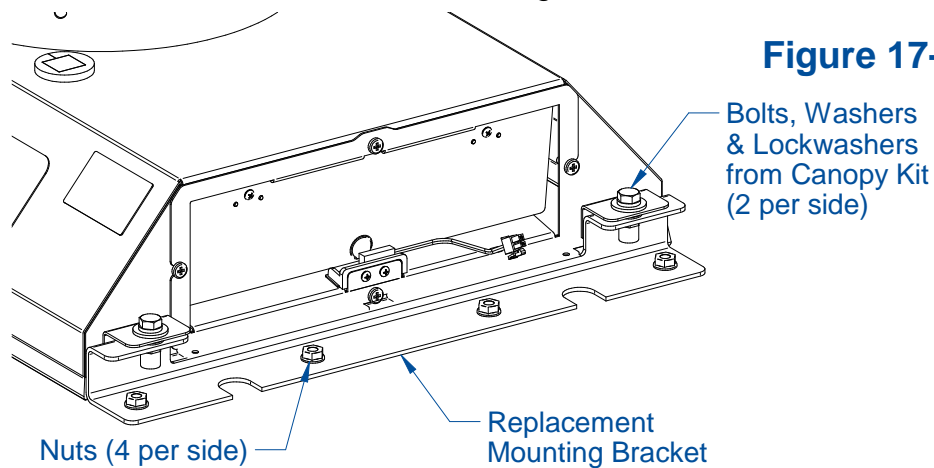
1. Turn off the Biosafety Cabinet.
2. If cabinet has an exhaust cover, remove the two phillips screws on the front face of the cover(s) and lift the front of the cover(s) up and pull out and away from the cabinet. For more detailed instructions, see *Removal of External Dress Panels* in [Section 12: Advanced Service Procedures](#).
3. Locate and remove the four nuts with a 7/16-inch nut driver that secure each of the exhaust brackets to the top of the unit.

- Lift the exhaust brackets straight up off of the top of the cabinet. Keep the nuts; you may also want to retain the cover(s) and angles for the future, if the cabinet will be disconnected from the exhaust system.



**Figure 17-3**

- Install the replacement brackets as shown. Install the nuts, but leave them loose. Reference Figure 17-4. For 8-ft Type A2 models, two sets will be installed (four brackets total).
- Carefully place the canopy between the brackets. Ensure the canopy fits on the inside of the two mounting brackets as shown. Line up the holes in the canopy connection with the threaded holes in the mounting bracket flanges. Reference Figure 17-4.
- Install the four canopy bolts, washers and lockwashers supplied with the canopy connection kit into the mounting bracket threaded holes and tighten them using a ½-inch wrench to secure the canopy as shown. Tighten the nuts installed in Step 4 with a 7/16-inch nutdriver. Reference Figure 17-4.



**Figure 17-4**

- For 8-ft Type A2 installations, repeat steps 5 and 6 on the other side.

## Exhaust Damper Installation Procedure

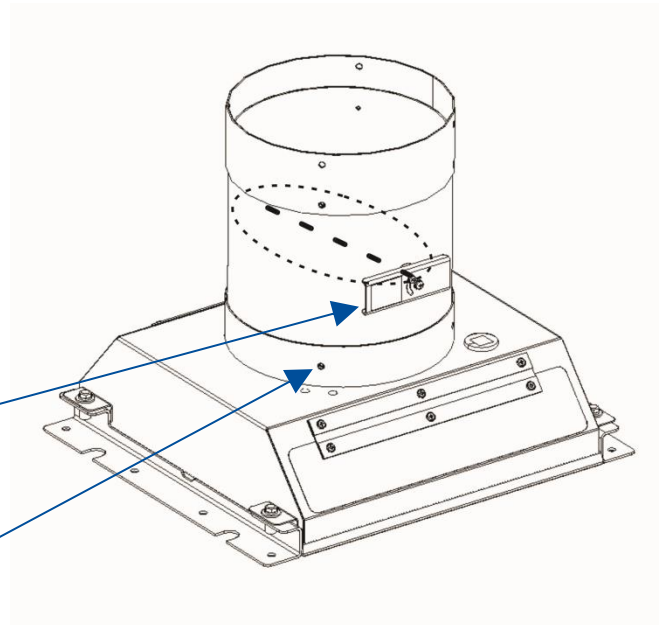
The air-tight damper shown is not supplied with the canopy kit. Proper installation of the canopy's damper is crucial for correct alarm system operation. If you have questions, please call Labconco's Product Service Department. Labconco offers an optional gas-tight exhaust damper (Catalog Number 3776800). An equivalent 10-inch OD damper can be used if desired. Labconco offers a low-profile, gas-tight exhaust damper (Catalog Number 3776802) for installations with ceiling height limitations.

Figure 17-5

1. Install the damper on top of the canopy(s), ensuring that the control lever faces the front of the unit as shown in Figure 17-5.
2. Use a proper silicone sealant (not supplied) and the screws supplied with the air-tight damper to seal the damper to the canopy(s).

Damper Flow Control Lever

Screws (4)

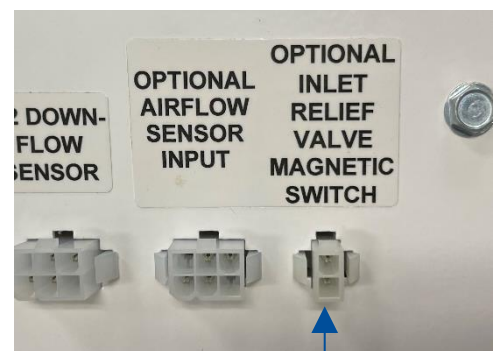


## Canopy Switch Wiring Connection

If installing the Canopy Connection Kit on a **3-ft, 4-ft, 5-ft or 6-ft model**, follow the instructions below:

1. Ensure that the cabinet is unplugged.
2. Connect the canopy connector to the two pin connector located on the left side of the electronics module (see Figure 17-6). Ensure there is slack in the sensor cable where it connects to the harness, and it does not impede the operation of the intake valve.

Figure 17-6



Lever-Connector of canopy wire harness here

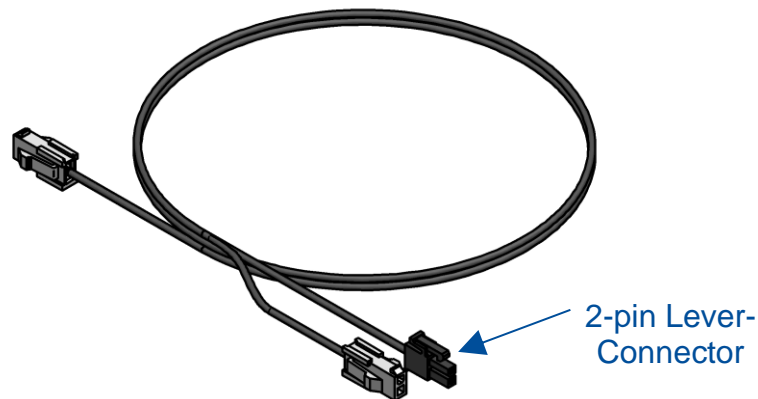


Ensure the sensor harness does not contact any moving parts.

If installing the Canopy Connection Kit on an **8-ft Type A2 Model**, follow the instructions below:

1. Ensure that the cabinet is still unplugged.
2. Locate the Canopy Connector Extension Cable from the kit. Find and study the dual connector end of the cable to find the two-pin Lever-Connector (see Figure 17-7).

**Figure 17-7**



3. Insert the Lever-Connector to the two-pin connector located on the left side of the Electronics (see Figure 17-6).
4. Connect the remaining connector on the dual end side of the cable to the Canopy closest to the Electronics Module via the Sensor Harness.
5. Route the remaining end of the Extension cable to the second Canopy and connect to the Sensor Harness.



Ensure there is slack in the Sensor Harness/Extension Cable where it connects to the harness, and it does not impede the operation of the intake valve.



Ensure the Sensor Harness/Extension Cable does not contact any moving parts.

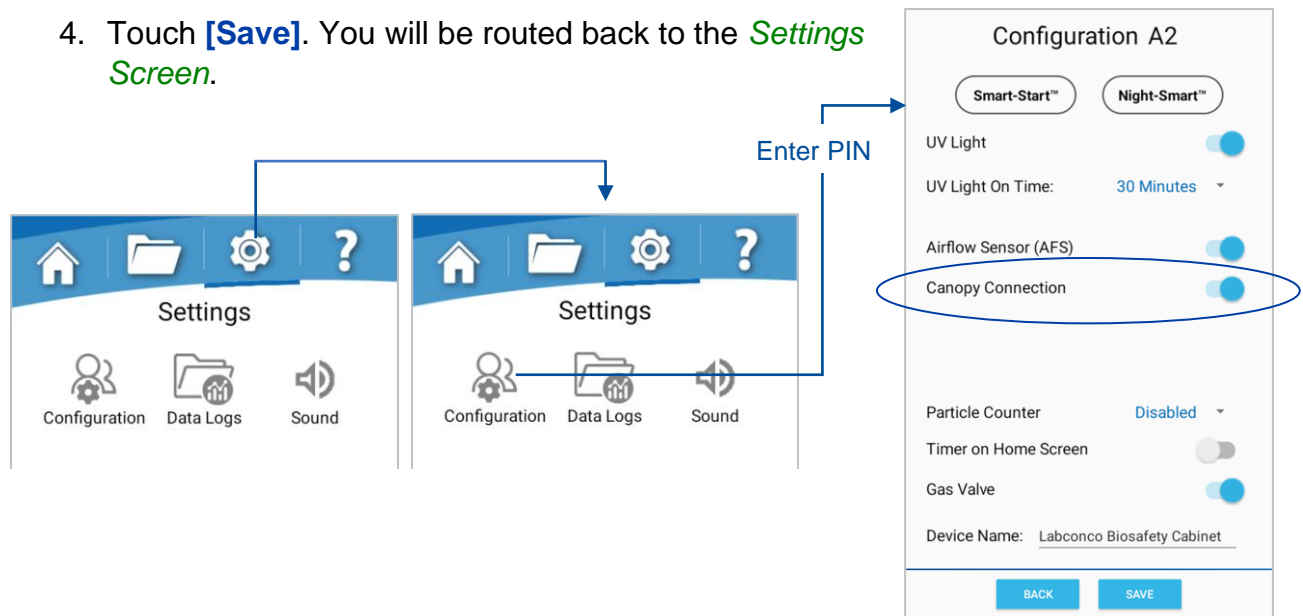
## Calibrate for Operation

After canopy installation, you **MUST** reconfigure the biosafety cabinet to have a canopy.



Keypad button presses and screen touches are shown as **[BLUE WITH BRACKETS]**. Menu screen selections are shown as *green italics*.

1. To access the *Settings Screen* from the *Home Screen*, touch **[Settings]** (represented by the gear-icon) on the Menu Bar of the display.
2. Touch **[Configuration]**. When prompted for a security code, enter **[1] [9] [2] [5]** or the user/admin PIN chosen for the device.
3. Touch the toggle next to *Canopy Connection* to enable the canopy features. It will appear blue when enabled as shown below.
4. Touch **[Save]**. You will be routed back to the *Settings Screen*.



5. Take the inflow and Downflow readings as described in [Section 10: Certification](#). If not within acceptable tolerance for the model, adjust the biosafety cabinet's internal damper and/or blower(s) speed until Inflow and Downflow are correct as described in [Section 9: Airflow Calibration](#). Use the original blower speed(s) as a reference.

## 18: Airflow Sensor Kit

---

To add an airflow sensor (AFS) to a Type A2 or C1 biosafety cabinet, follow these instructions. If replacing an airflow sensor, it is not necessary to configure the airflow sensor, as the biosafety cabinet will already have this feature enabled.



**Note:** These instructions describe installation on a Type A2 biosafety cabinet. Installation on a Type C1 is very similar, except the installation location is in the exhaust housing, and the sensor wire pass-thru is in the rear of the exhaust housing.



**Note:** All 8-foot Type A2 Models have dual exhaust, which require installing two (2) AFS; follow the entire instructions below and repeat for other side. *Notes for 8-foot specific instructions are included in italics throughout the subsection.*

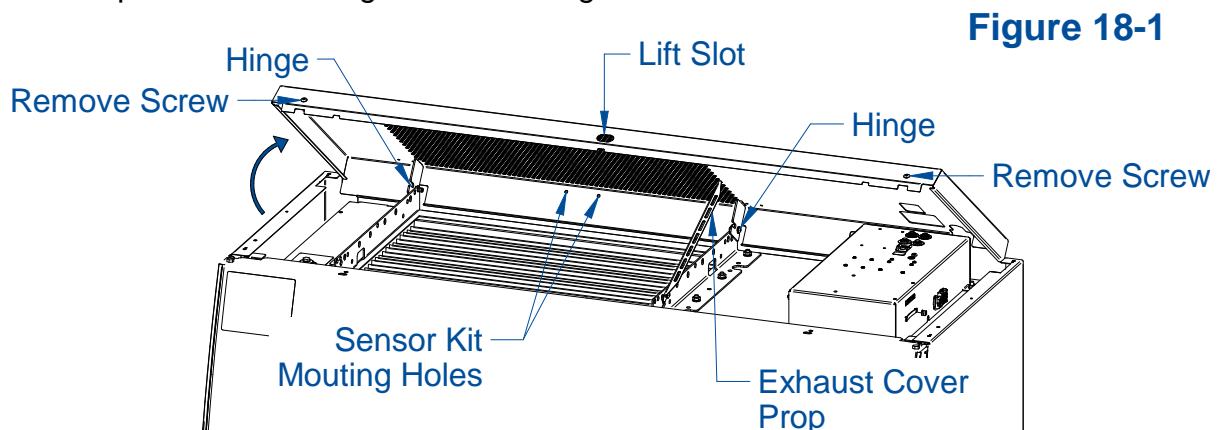


Exercise caution when working around the exhaust HEPA filter atop the biosafety cabinet. The filter media can be damaged easily. Never touch the filter media.

### Installation – Type A2 without Ventus II canopy

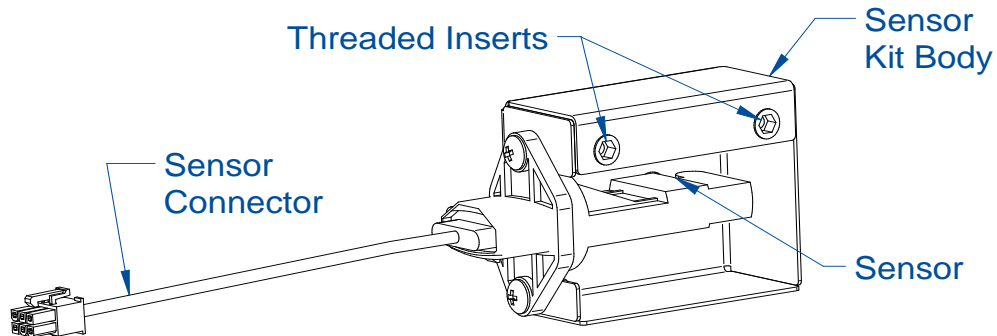
Airflow Sensor Kit Catalog Number: 3277600 & 3277608 (*for 8-ft A2 only*)

1. Disconnect all power from the biosafety cabinet by unplugging the power cord.
2. Remove the two phillips screws in the front of the cover(s) shown in Figure 18-1. *An 8-ft model will have two covers, repeat as needed.*
3. Hinge the cover(s) up from the front using the lift slot. Tilt it enough to access the underside of the cover.
4. The exhaust cover(s) can be secured in the lifted position by using the exhaust cover prop. Rotate the prop up and against the exhaust cover. Insert the end of the prop into the exhaust cover perforations to keep the cover lifted to height required for servicing. Reference Figure 18-1.



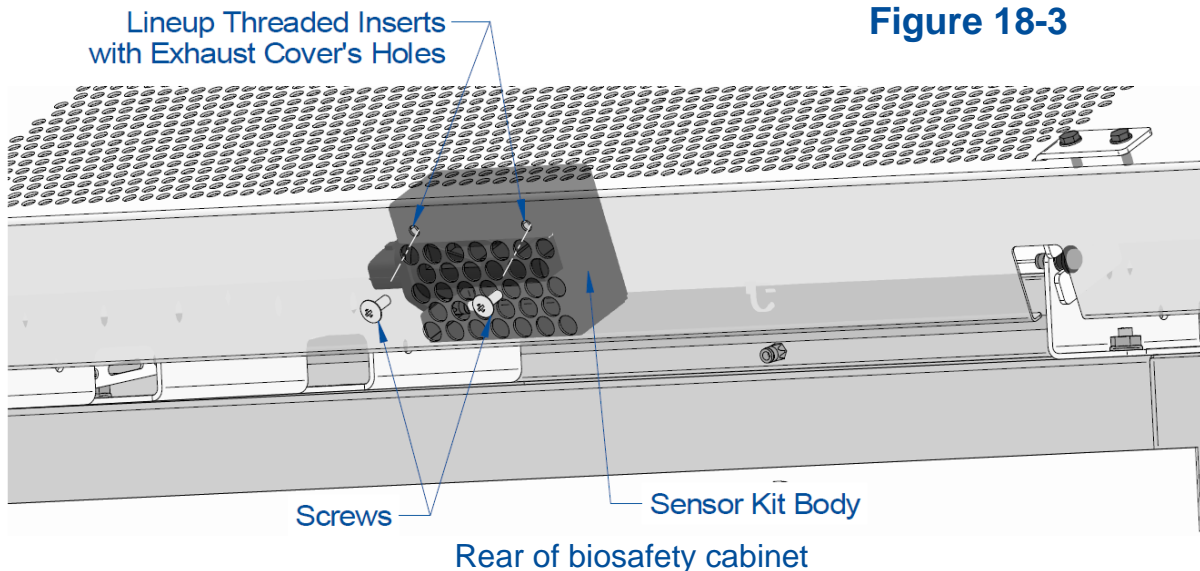
- Carefully lower the exhaust cover onto the prop and release when stable. Do not release the exhaust cover if the prop is not fully in place against the cover.
- Locate the two phillips screws included in the kit and familiarize yourself with the sensor kit. See Figure 18-2. Do **NOT** pull the sensor out of the body. *For 8-ft models, there will be four phillips screws and two sensor kits.*

**Figure 18-2**



- Position the sensor kit on the underneath side of the exhaust cover. From the rear of the cabinet, line up threaded inserts of the sensor kit with the mounting holes in the rear side of the exhaust cover. Install the two phillips screws located in the previous step through the exhaust cover and into the sensor kit's inserts. Tighten the two screws. See Figure 18-3 for reference.

**Figure 18-3**



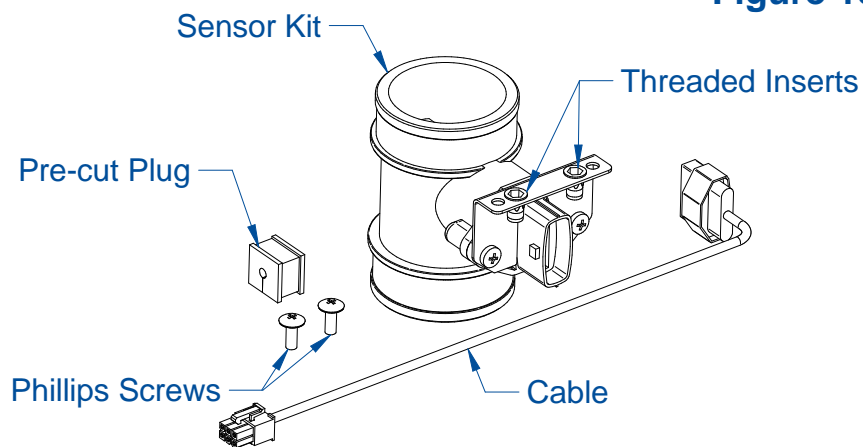
- If installing on 8-ft model, repeat step 7 on the remaining exhaust cover.

## Installation – Type A2 with Ventus II canopy

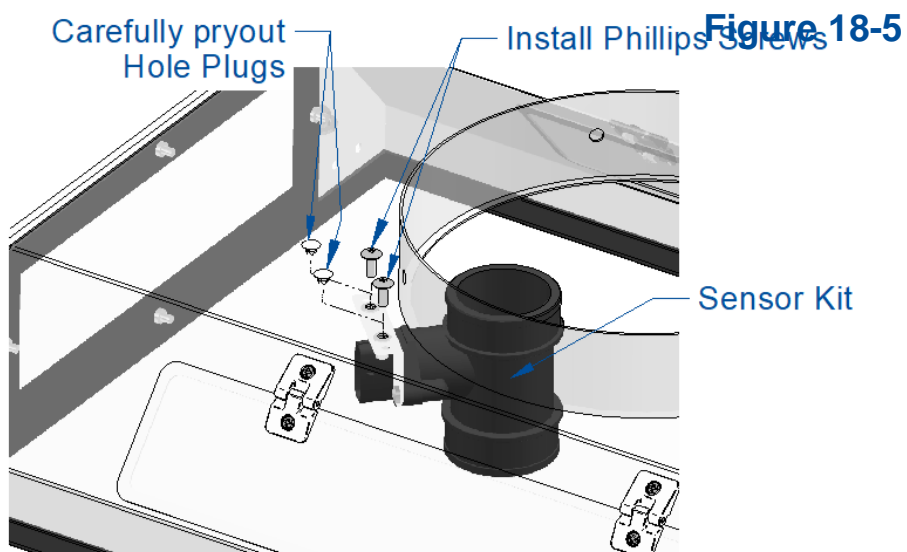
Airflow Sensor Kit Catalog Number: 3277610 & 3277618 (for 8-ft A2 only)

1. Disconnect all power from the biosafety cabinet by unplugging the power cord.
2. Locate the two phillips screws and pre-cut plug included in the kit and familiarize yourself with the sensor kit. See Figure 18-4. Do **NOT** pull the sensor out of the body. For 8-ft models, there will be four phillips screws and two sensor kits.

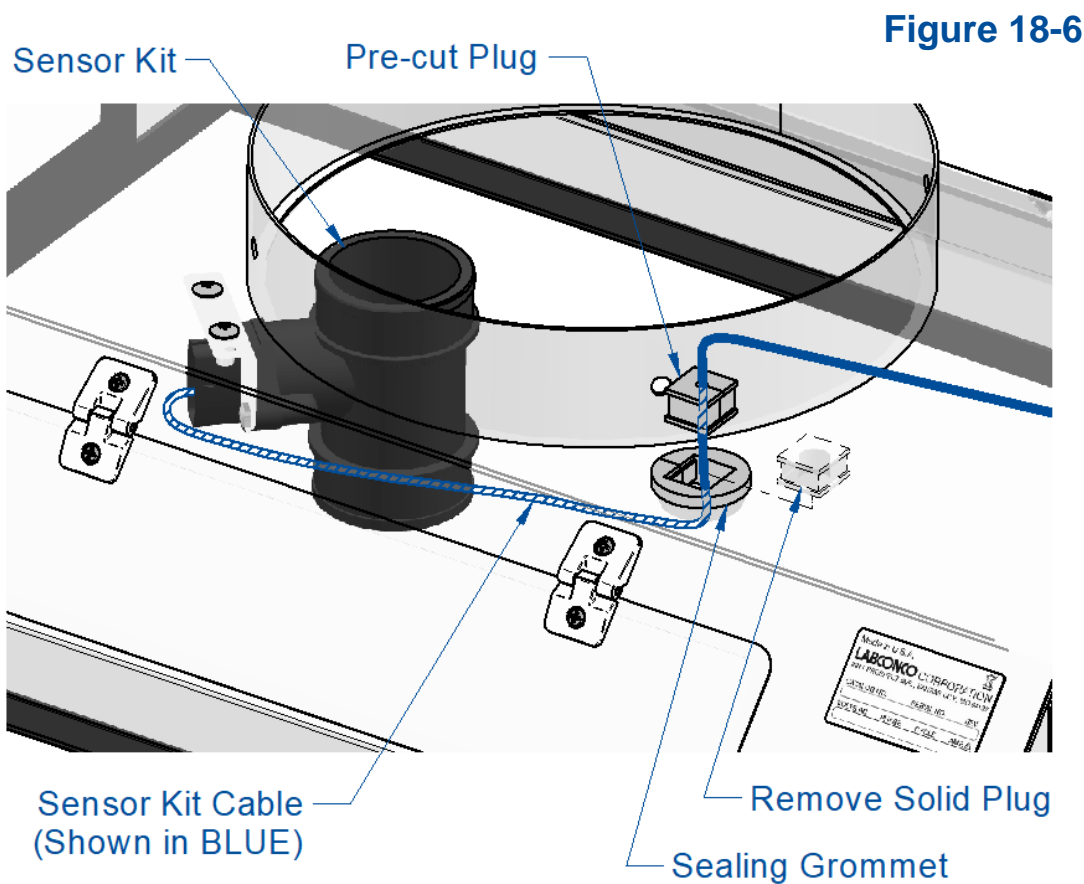
**Figure 18-4**



3. For new installation, pry out the two hole plugs in the top of the canopy (A2) or exhaust housing (C1). Working through the duct stub opening, or one of the service panel openings, place the airflow sensor as shown in Figure 18-5. Secure the sensor with two attachment screws supplied in the kit.



4. New installation only – Gently remove the square solid plug from inside the sealing grommet, located on the top of the canopy (Type A2) or exhaust housing (Type C1).
5. Run the cable and its connector through the hole of the sealing grommet. Make any final adjustments to the location of the sealing grommet/pre-cut plug on the airflow sensor cable. Gauge the location of the replacement plug on the cord based on where the sensor will sit when installed. Locate the pre-cut plug from the airflow sensor kit. Push the cable from the airflow sensor into the slit in the pre-cut plug.
6. Install the pre-cut plug into the Sealing grommet, noting the keyed orientation between the grommet and the plug. See Figure 18-6 to identify the grommet and plugs described.



7. For 8-ft models, repeat steps 3 through 6 on the second canopy.

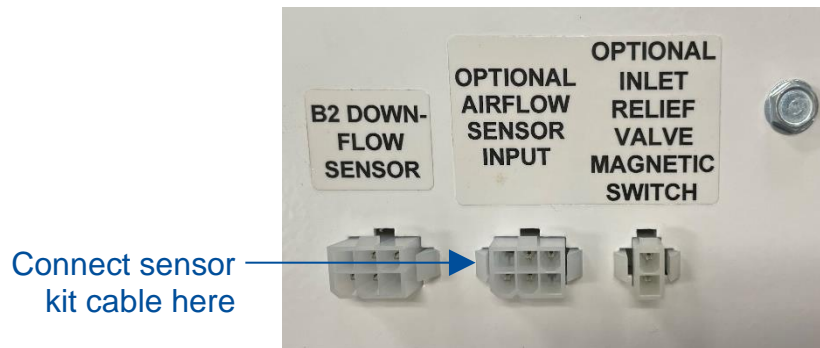
## Connection to Electronics Module

After installation, follow these steps to connect the airflow sensor to the biosafety cabinet's electronics module.

If installing the AFS Kit on **3-ft, 4-ft, 5-ft or 6-ft models**, follow the instructions below:

1. Identify the "Optional Airflow Sensor Input" label on the left side of the biosafety cabinet's electronics module. See Figure 18-7.

**Figure 18-7a**

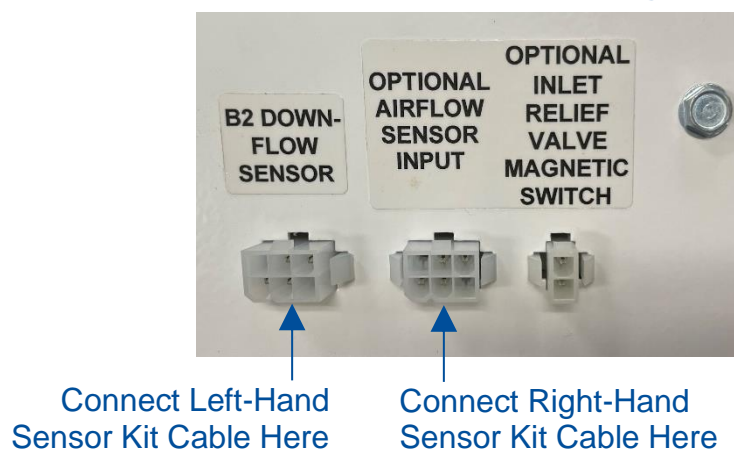


2. Connect the airflow sensor cable to this connector on the electronics module.
3. Tidy up excess length of cable from the airflow sensor by creating a few loops if necessary, and zip tie the loops.
4. Secure the cable to the top, front lip of the biosafety cabinet with zip ties to ensure it does not interfere with the sash pulley axle.

If installing the AFS Kit on **8-ft models**, follow the instructions below:

1. Identify the "Optional Airflow Sensor Input" label on filter-facing side of the biosafety cabinet's Electronics Module. See the figure below.

**Figure 18-7b**



2. Connect the right-hand Airflow Sensor Cable to the 'Optional Airflow Sensor Input connector on the Electronics Module.
3. Connect the left-hand Airflow Sensor Cable to the 'B2 Downflow Sensor' connector on the Electronics Module.
4. Tidy up excess length of cable from the airflow sensor by creating a few loops if necessary, and zip tie the loops. Secure the cable to the top, front lip of the biosafety cabinet with zip ties to ensure it does not interfere with the sash pulley axle.

For **ALL models**:

5. Replace and secure the Exhaust Covers if applicable.
6. Reconnect the biosafety cabinet to electrical power.

## Configuration (new install only)

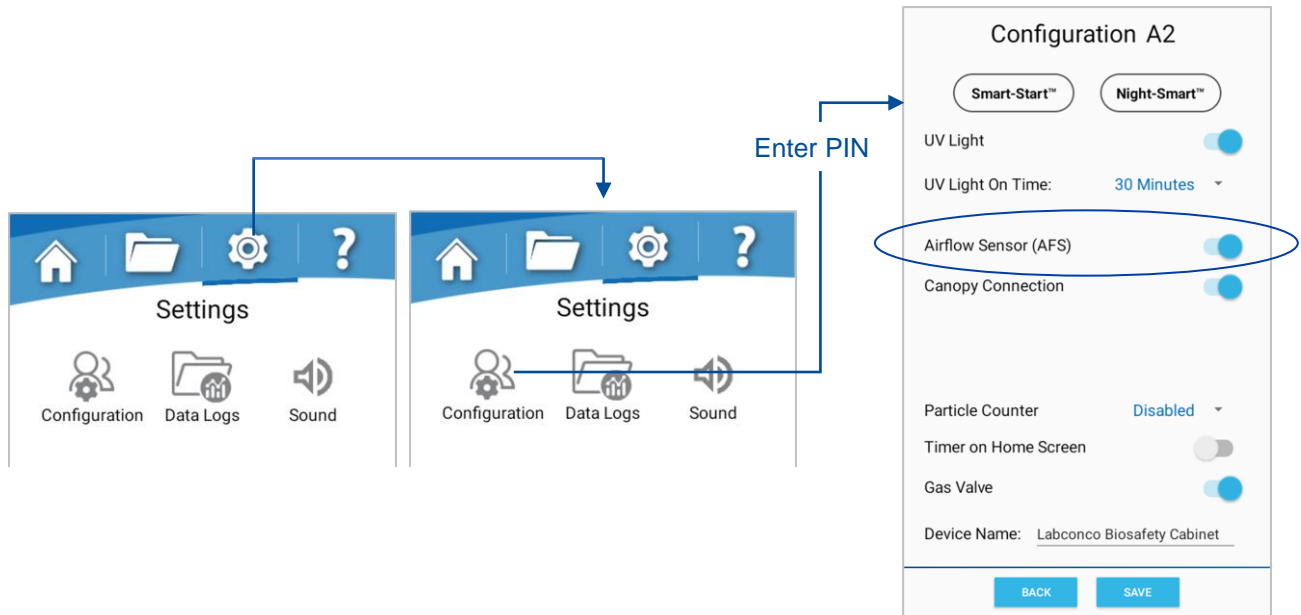
After airflow sensor installation, you **MUST** reconfigure the biosafety cabinet to enable the airflow sensor.



Keypad button presses and screen touches are shown as **[BLUE WITH BRACKETS]**. Menu screen selections are shown as *green italics*.

1. To access the *Settings Screen* from the *Home Screen*, touch **[Settings]** (represented by the gear-icon) on the Menu Bar of the display.
2. Touch **[Configuration]**. When prompted for a security code, enter **[1] [9] [2] [5]** or the user/admin PIN chosen for the device.

3. Touch the toggle next to *Airflow Sensor (AFS)* to enable the AFS features. It will appear blue when enabled as shown below.
4. Touch **[Save]**. You will be routed back to the *Settings Screen*.



## Calibration

After airflow sensor installation, you **MUST** calibrate the new sensor. Follow these steps to calibrate the new sensor.

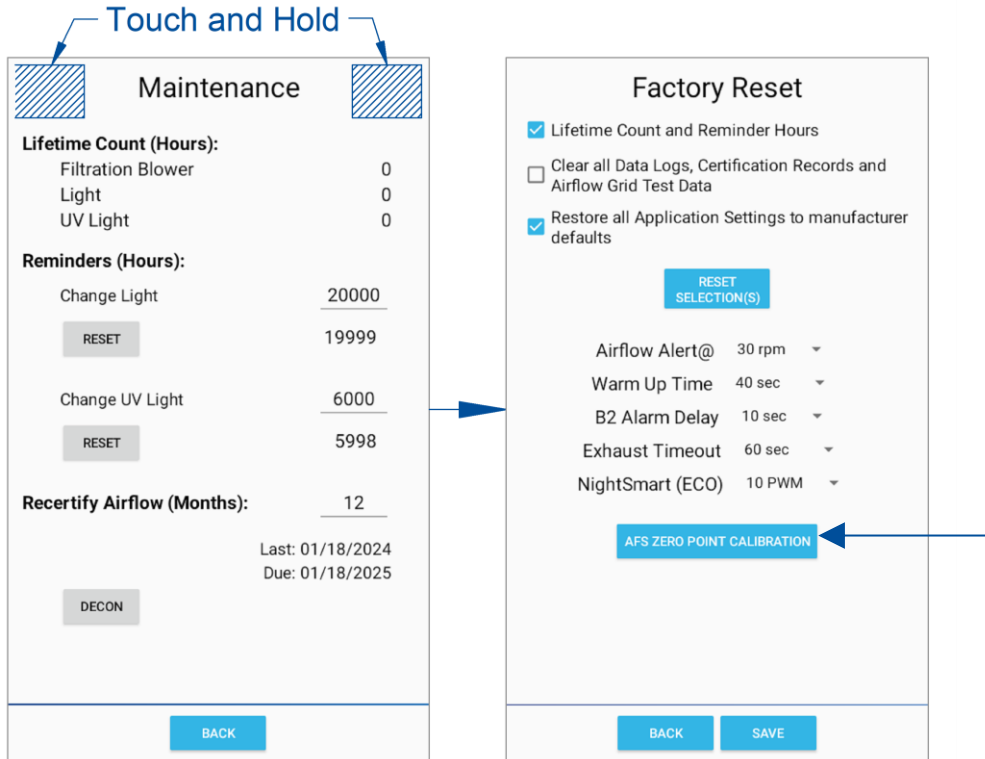


**Note:** To properly calibrate the airflow sensor, a qualified certifier must verify the inflow and downflow values.

If installing or replacing an Airflow Sensor, the sensor will need a zero-point calibration. See *Airflow Sensor Zero-point Calibration* in [Section 9: Airflow Calibration](#) for more information. To zero-point calibrate the newly installed AFS, turn off the cabinet blower(s) and remove any airflow from a remote blower (if applicable). Follow the directions below:

1. Access the *Settings Screen* by touching **[Settings]** (represented by the gear-icon) on the Menu Bar of the display.
2. Touch **[Maintenance]** (represented by the wrench-icon).
3. Touch and hold the top two corners of the display until the screen changes to *Factory Reset*.
4. Locate and touch **[AFS Zero-point Calibration]** as shown.

5. Follow the prompts on the screen until calibration is complete.
6. To exit *Maintenance* touch **[Back]**. Touch **[Back]** again.



**IF THE UNIT IS CONNECTED TO AN EXHAUST SYSTEM, YOU MUST STOP ALL AIRFLOW OVER THE SENSOR DURING THE INITIAL ZEROING OF THE SENSOR - DO THIS BY SHUTTING OFF THE EXHAUST SYSTEM, OR BLOCKING THE SENSOR INTAKE WITH TAPE.**

If installing or replacing an Airflow Sensor, the sensor will need to be calibrated at nominal airflow. See *Adjusting Blower Speed* in [Section 9: Airflow Calibration](#) and *Downflow/Inflow Velocity* in [Section 10: Certification](#) for more information. To calibrate the newly installed AFS, follow the directions below:

7. Access the *Settings Screen* by touching **[Settings]** (represented by the gear-icon) on the Menu Bar of the display.
8. Locate and touch **[Certification]** (represented by the calipers-icon) on the *Settings Screen*.

9. From the *Warning Screen*, touch **[Continue]** to acknowledge the warning that the following screens are restricted.

10. When prompted for a password, enter: **[1] [9] [2] [5]**. You will now be in the *Certification* page.



If installing a new airflow sensor, the zero-point calibration of the airflow sensor needs to be done before nominal airflow calibration.



Never enter the password-protected area, or change settings of the biosafety cabinet if you are not a trained and qualified certifier or technician. Changing parameters in the password-protected area may impair the product's performance and result in loss of protection and/or harm or death to personnel in the laboratory.

11. Touch **[Certify]**. When prompted, enter your name/organization and touch **[Next]**. You are now in certify mode. If not already on, the internal blower(s) will start.



**Note:** The sash must be at operating height when calibrating airflow. See [Section 10: Certification](#) for more information on measuring airflows.

**Certification**

Last: NOT CERTIFIED Due:

**Blower Speed (RPM)**

	AVG/ INSTANT	NEW/ MAX
Left	364 / 371	0 / 1500
Right	287 / 287	0 / 1500

**Blower Power (%)**

Left ▲ 50% ▼

Right ▲ 50% ▼

**Airflow Sensor (fpm)**

Downflow ▲ 55 fpm ▼

Inflow ▲ 105 fpm ▼

SAVE

AIRFLOW GRID BACK

*Average/Instantaneous Blower RPM*

*Active for adjusting via keypad*

*Blower PWM(s)*

Touch this icon for the AFS value(s) to jump to the values as shown.

'Save' displayed as blue when blower speed stabilizes

12. Touch the [▲] and [▼] on the display to adjust the blower speed or use the [UP] or [DOWN] keys. Only the 'active' (shown by being highlighted in BLUE) can be adjusted via the keypad. To navigate to the next adjustable Blower PWM or AFS value using the keypad, press the [OK/MUTE] key. Each single press of [UP] or [DOWN] increments the PWM signal sent to the blower by 1.
13. When the Instantaneous Blower rpm is within 15 rpm of the Average Blower RPM, the blower speed has stabilized, and [Save] can be touched to move to the next screen.
14. *Select HEPA Filter Status* pop-up will appear; there are three options to choose from when resetting the Filter Life Status. Below are the three options, and an explanation on which to select.
  - *New Filter(s) Installed* – Select this option when the HEPA filters are new. This occurs during initial certification of a new biosafety cabinet, or after new HEPA filters are installed and the biosafety cabinet's Inflow and Downflow have been verified by a trained and qualified certifier.
  - *Same Filter* – Select this option when passing through this screen in the Calibration submenu to reach the sensor calibrations, or when the blower speed(s) have been adjusted slightly (but the HEPA filters have not been replaced) during an annual certification.
  - *Adjust Filter Life* – This option is seldom selected. It may be used to set the Filter Life status to a specific percentage, for example, after the display circuit board is replaced, and the settings from the previous display board need to be programmed into the new display board.

Once your selection has been made, touch [Save]. Once all calibrating is complete, you will be routed back to the *Home Screen*.

## 19: UV Lamp Kit

---

All biosafety cabinets are pre-wired for installation of the UV Lamp Kit.

### Kit Catalog Numbers

The kit consists of the UV Ballast, UV Lamp, Relay, Lamp Sockets, and installation hardware. It can be ordered by Catalog Part Number 3289100. If installing on an 8-ft model, order catalog Part Number 3289101.

### Installation



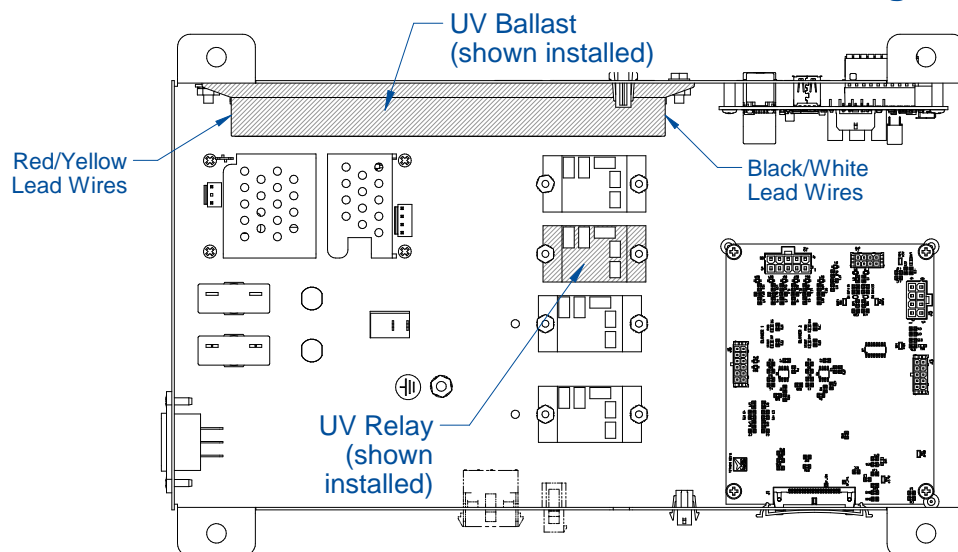
A qualified electrician or certifier should install this kit.



Decontaminate all interior work surfaces before installing the UV Lamp.

1. Disconnect all electrical power to the biosafety cabinet by unplugging the power cord.
2. If cabinet has an exhaust cover, remove the two phillips screws on the front face of the cover and lift the cover up and out of the way. If unit has two exhaust covers, only work on the right cover. Fully remove or use the prop as needed. For more detailed instructions, see *Removal of External Dress Panels* in [Section 12: Advanced Service Procedures](#).
3. Using a 7/16-inch socket or nut driver, remove the four nuts holding the electronics module to the top of the biosafety cabinet. Each corner of the module is secured with a nut.
4. Tip the module on its side and secure it.
5. Install the UV ballast with the hardware (two screws, washers and nuts) provided in the kit. See Figure 19-1 for reference. The ballast should be installed with the Black/White leads on the right side as viewed from Figure 19-1.
6. Install the relay as shown in Figure 19-1, and secure it with the hardware provided in the kit.

**Figure 19-1**



7. Identify the four circuit wire connectors described below, remove the protective black cover from each connector with a utility knife, and wire the relay.

Relay Coil: 6-ORG & 4BC-BLU (no orientation sensitivity)  
NO (normally open): 25-ORG  
COM (common): 3E-BLK

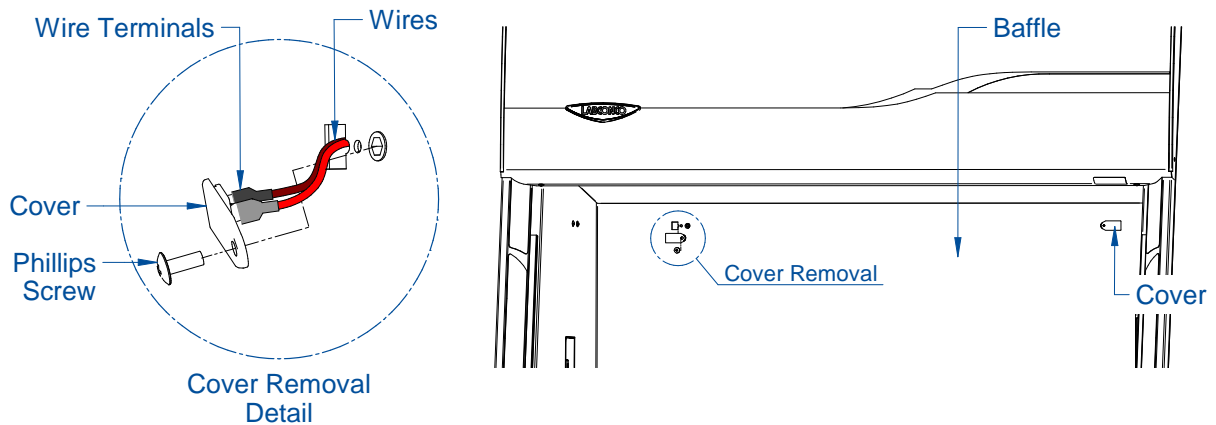
8. Connect the UV ballast into the electronics module wiring harness as described below:

UV Ballast Wires

White wire	2E-WHT
Black wire	25-ORG
Red wires	16A-RED & 16B-RED (no orientation sensitivity)
Yellow wires	18A-BLU & 18B-BLU (no orientation sensitivity)

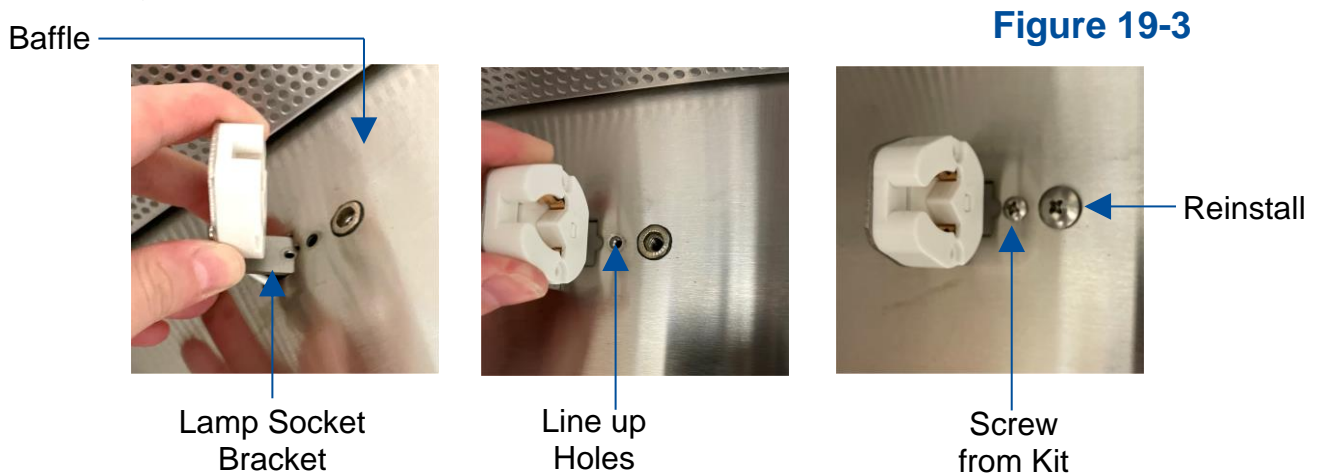
9. Reattach the electronics module to the top of the biosafety cabinet and tighten the four nuts previously removed.
10. Reverse Step 2 to reinstall the exhaust cover (if applicable).
11. Raise the sash and locate the Covers on the back baffle of the cabinet's work area. Reference Figure 19-2. Using a phillips head screwdriver, remove the screw securing each Cover.
12. Slide the cover towards the center of the cabinet and gently pull the cover away from the baffle. There will be wires connected to the back of the cover (reference Figure 19-2). Do not lose these wires.

**Figure 19-2**



13. Pull each wire terminal off the Cover and install onto the Lamp Sockets from the kit (no orientation sensitivity). Repeat as needed. Feed the wiring back into cutout of the baffle once securely installed onto the socket leads.

14. Install the bracket of the Lamp Socket by sliding the end of the bracket into the baffle cutout as shown in Figure 19-3. Line up the hole in each socket bracket with the baffle hole and install the small phillips screw from the kit. Reinstall the phillips head screw removed with the Cover. Repeat as needed. Reference Figure 19-3.



Note: The Covers are no longer needed. Save them if UV Kit is not a permanent install.

15. Install the UV lamp(s) by placing the lamp pins into each socket, pressing down on the UV lamp (gently), and then rotating the lamp 90 degrees to lock it in the lamp sockets.

16. Lower the sash to the fully closed position. Restore electrical power to the biosafety cabinet.

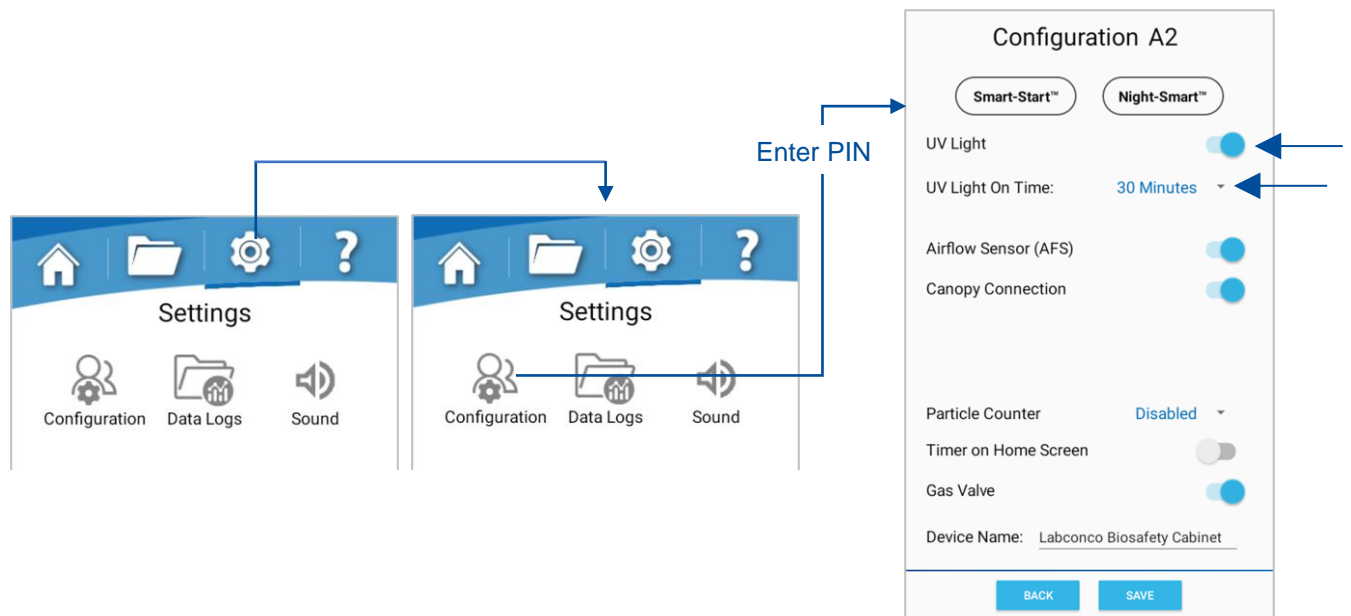
## Configuration

After UV Lamp components are installed, you **MUST** reconfigure the biosafety cabinet to enable the UV lamp.



Keypad button presses and screen touches are shown as **[BLUE WITH BRACKETS]**. Menu screen selections are shown as *green italics*.

1. To access the *Settings Screen* from the *Home Screen*, touch **[Settings]** (represented by the gear-icon) on the Menu Bar of the display.
2. Touch **[Configuration]**. When prompted for a security code, enter **[1] [9] [2] [5]** or the user/admin PIN chosen for the device.
3. Touch the toggle next to *UV Light* to enable the UV Light features. It will appear blue when enabled as shown below.
4. To change the *UV Light On Time* from the default 30 minutes, touch the time or **[▼]**. Scroll through the options and touch the desired time. The drop-down menu will disappear and your choice will be visible in blue.
5. Touch **[Save]**. You will be routed back to the *Settings Screen*.



## 20: IV Bar Kit

All biosafety cabinets are prepared with the necessary mating hardware to accept an IV Bar Kit. To install the IV Bar, follow these instructions.

### Kit Catalog Numbers

Table 20-1

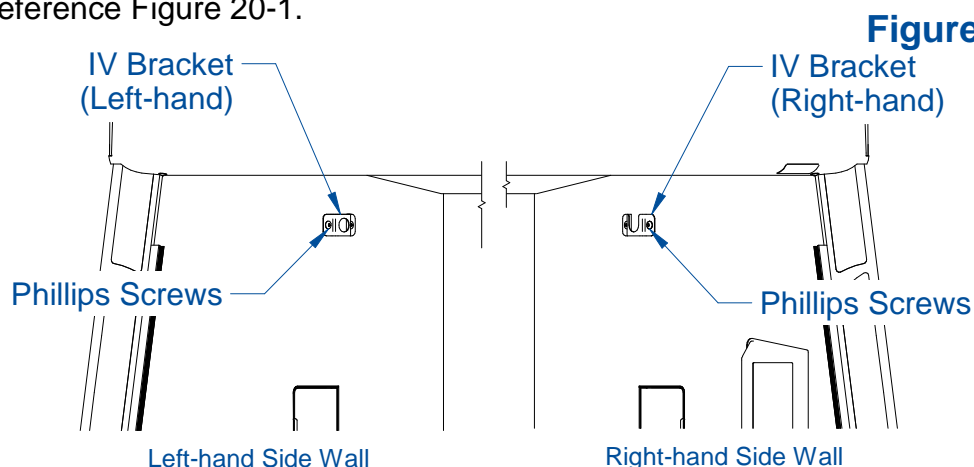
Cabinet width (feet)	Catalog Number
3-ft	3288900
4-ft	3288901
5-ft	3288902
6-ft	3288903
8-ft	3288904

### Installation

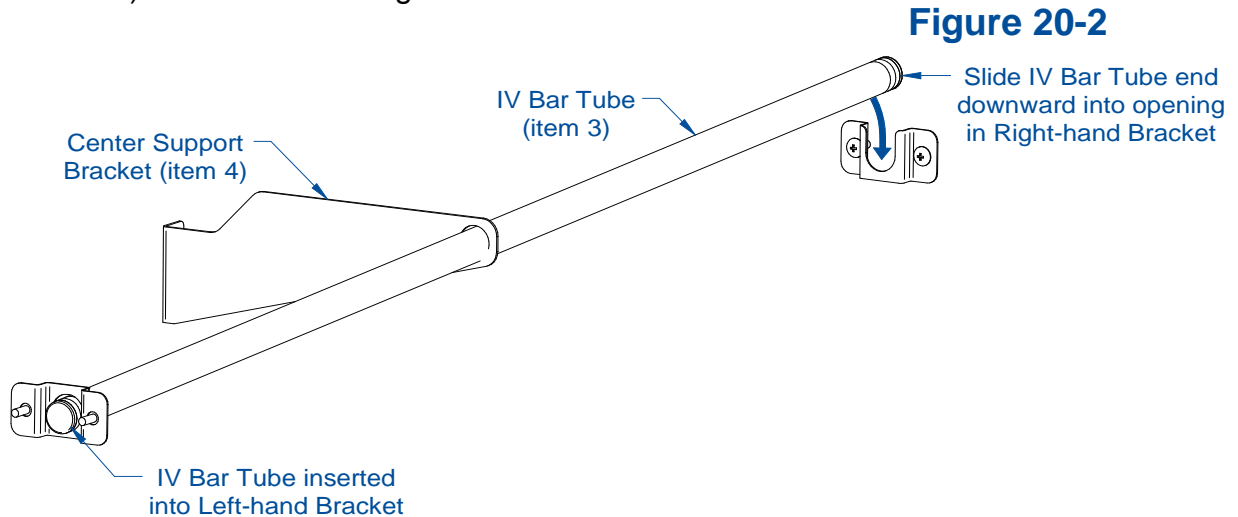


Decontaminate all interior work surfaces before installing the IV Bar.

1. Disconnect power to the biosafety and raise the sash to the fully open position.
2. Remove the four screws on the sidewalls using a screwdriver. If installing on an 8-ft model, locate and remove the two screws on the back baffle. Save this hardware.
3. Identify the Left IV Bracket (closed-hole) and mount on left sidewall with 2 of the screws removed in the previous step. Do not fully tighten. Reference Figure 20-1.
4. Identify the Right IV Bracket (open slot) and orient with the open slot end facing up. Secure the bracket using the remaining screws removed from Step 2. Reference Figure 20-1.



5. If installing on an 8-ft model, locate and slide the Center Support bracket onto the IV Bar.
6. Insert one end (no orientation sensitivity, but if applicable, with the Center Support Bracket facing flange towards the Rear Baffle) of the IV Bar Tube into the Left-hand Bracket (close-holed), and slide the remaining end of the IV Bar Tube downward into the U-shaped opening of the Right-hand Bracket (open slot). Reference the Figure 20-2.



7. Tighten any screws that may be loose. Use provided hooks as desired.

## 21: Prefilter Kit

---

All Type A2 and B2 biosafety cabinets are prepared with the necessary mating components to accept a Pre-filter Kit. To install the Pre-filter Kit, follow these instructions.

### Kit Catalog Numbers (Type A2 and B2 only)

**Table 21-1**

Cabinet width (feet)	Catalog Number	QTY of kits needed
3-ft	3288600	1
4-ft	3288601	1
5-ft	3288602	1
6-ft	3288603	1
8-ft	3288601	2

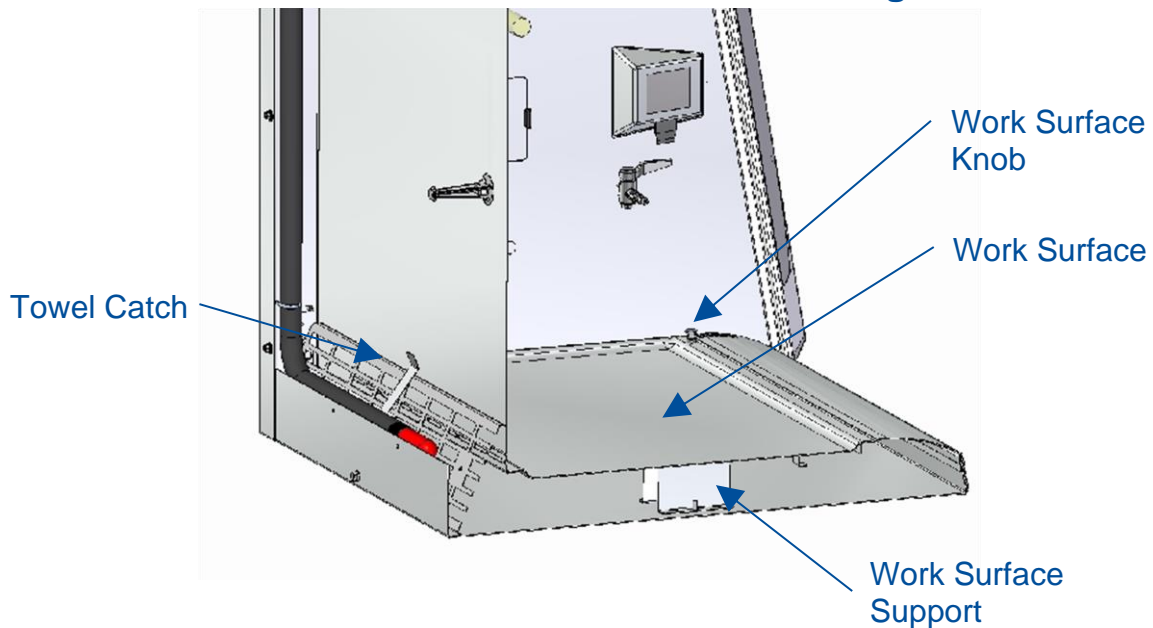
### Installation



Decontaminate all interior work surfaces and work surface components before installing the prefilter.

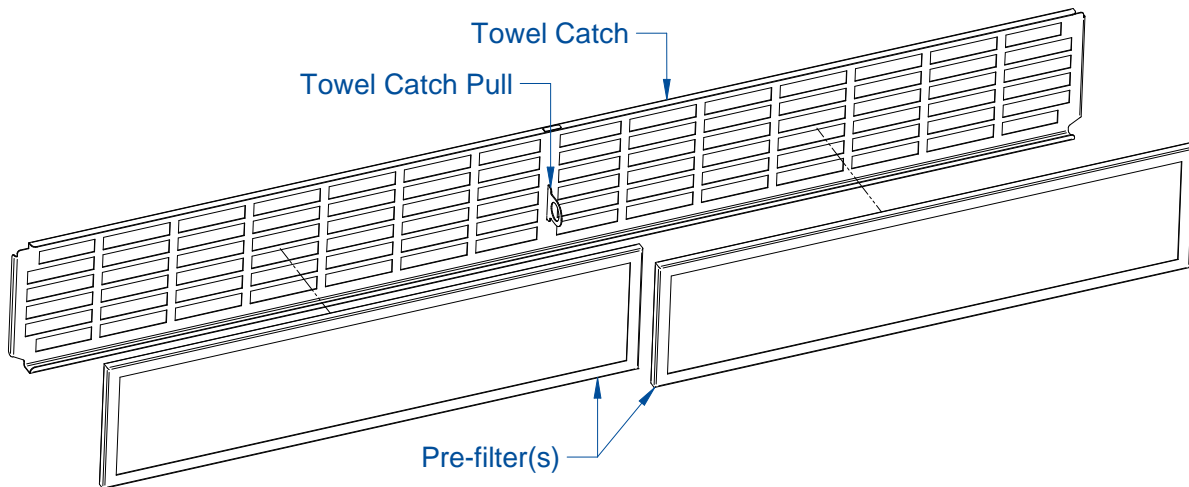
1. Remove the work surface of the cabinet by lifting the front edge by one of the front corner knobs. Slide the work surface forward to disengage the rear tabs. Support the underneath side with one hand while stabilizing the front edge with the other. Set the work surface aside. Reference Figure 21-1.
2. If needed, pinch and lift the work surface support straight up to remove it. Make sure it is surface decontaminated before removing it from the biosafety cabinet. Reference Figure 21-1.
3. Access the towel catch by pivoting the bottom out towards you. Surface decontaminate the towel catch before removing it from the biosafety cabinet. Reference Figure 21-1.

**Figure 21-1**



4. Locate the pre-filter(s) and towel catch from the Kit.
5. Set the pre-filter(s) into the towel catch so they are located between the top and bottom long flanges on the towel catch. See Figure 21-2.

**Figure 21-2**



6. Install the filtered towel catch by reversing the motions used to remove it. Push the filtered towel catch toward the back of the cabinet and pivot the bottom edge of the catch away from you.



Only one prefilter is used on 3-ft models. There is no towel catch pull on 3-ft models.

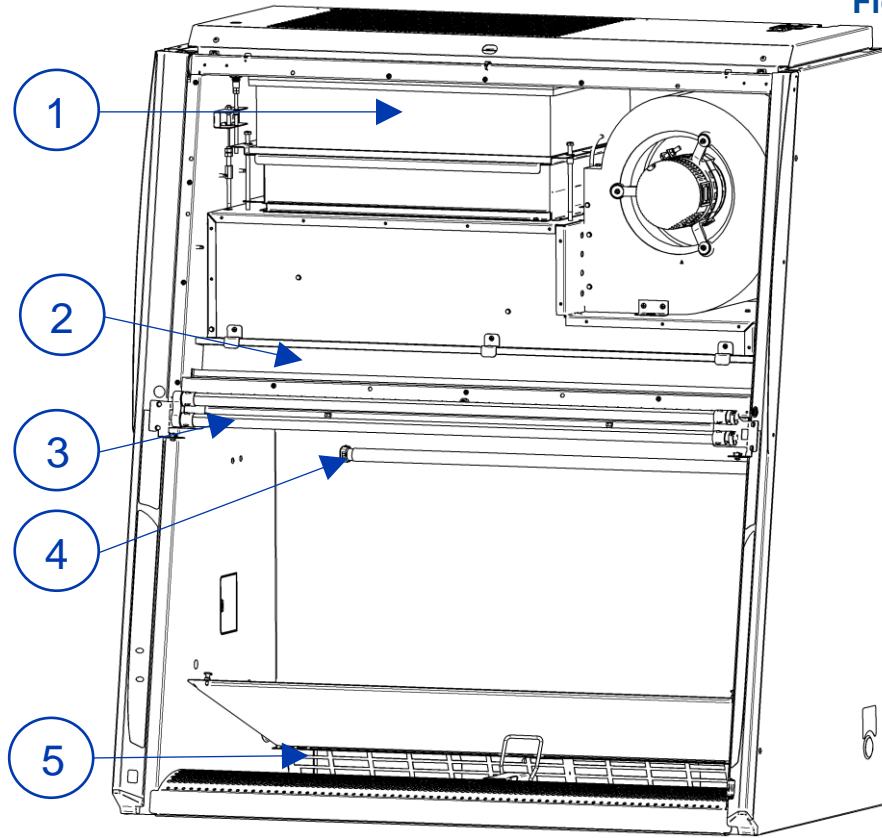
## 22: Parts List

### Type A2 Consumables

Table 22-1

Item	Quantity Required	Catalog Number	Description
1	1	3838505	Exhaust HEPA Filter 3 Foot Model
	1	3838501	Exhaust HEPA Filter 4 Foot Model
	1	3838502	Exhaust HEPA Filter 5 Foot Model
	1	3838503	Exhaust HEPA Filter 6 Foot Model
	2	3838501	Exhaust HEPA Filter 4 Foot Model
2	1	3838410	Supply HEPA Filter 3 Foot Model
	1	3838411	Supply HEPA Filter 4 Foot Model
	1	3838412	Supply HEPA Filter 5 Foot Model
	1	3838413	Supply HEPA Filter 6 Foot Model
	2	3838411	Supply HEPA Filter, 8 Foot Model
3	2	1297503	Lamp, LED, 3 Foot Model
	2	1297504	Lamp, LED, 4 Foot Model
	2	1297505	Lamp, LED, 5 Foot Model
	2	1297506	Lamp, LED, 6 Foot Model
	4	1297504	Lamp, LED, 8 Foot Model
4	1	1271300	Lamp, UV (3'/4'/5'/6' models w/ UV only)
	2	1271300	Lamp, UV (8' models w/ UV only)
5	1	3795301	Prefilter, 36" (Qty. 1 per 3 Foot Puricare Model)
	2	3795300	Prefilter, 24" (Qty. 2 per 4 Foot Puricare Model)
	1 / 1	3795300 / 3795301	Prefilter (Qty. 1 each size 5 Foot Puricare Model)
	2	3795301	Prefilter, 36" (Qty. 2 per 6 Foot Puricare Model)

Figure 22-1

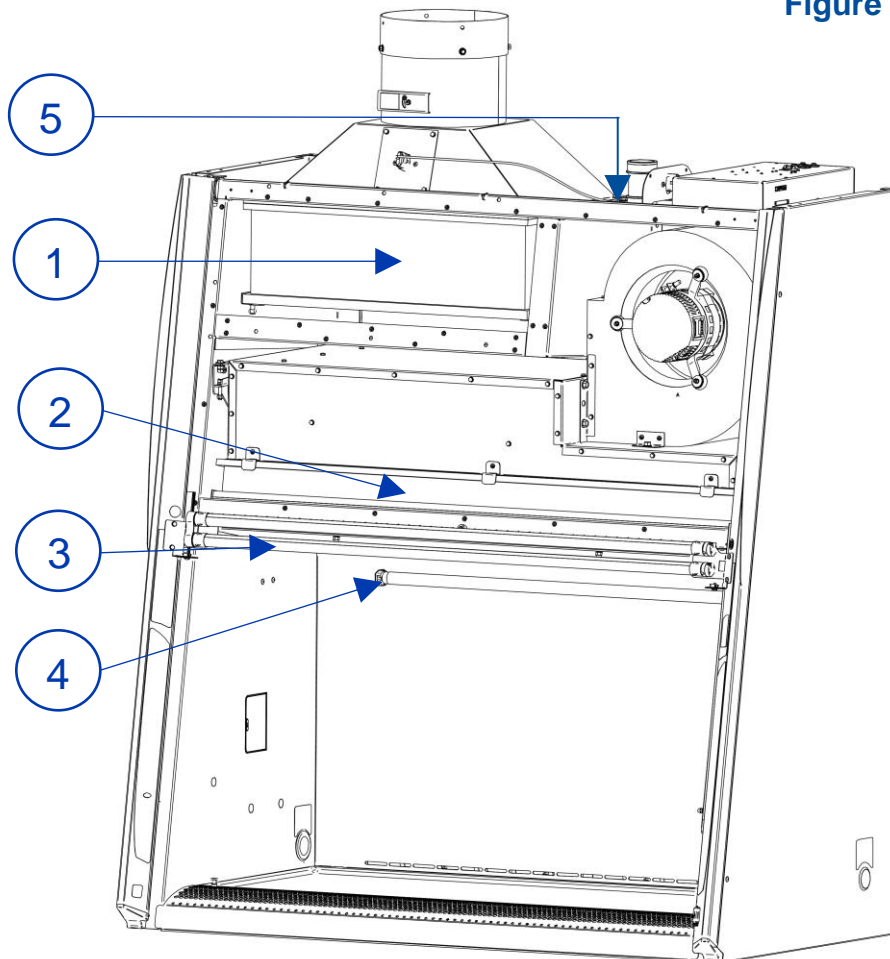


# Type B2 Consumables

**Table 22-2**

Item	Quantity Required	Catalog Number	Description
1	1	3438501	Exhaust HEPA Filter 4 Foot B2 Model
	1	3438503	Exhaust HEPA Filter 6 Foot B2 Model
2	1	3838411	Supply HEPA Filter 4 Foot Model
	1	3838413	Supply HEPA Filter 6 Foot Model
3	2	1297504	Lamp, LED, 4 Foot Model
	2	1297506	Lamp, LED, 6 Foot Model
4	1	1271300	Lamp, UV (models with UV light only)
5	1	3850500	Prefilter for 4 Foot B2 Model
	1	3850501	Prefilter for 6 Foot B2 Model

**Figure 22-2**



## Advanced Service Components

Table 22-4

Item	Shown on Figure	Catalog Number	Description
1	22-4	3278500	Keypad
2		3832400	Sash Sensor Switch
3		3322900P	Work Surface, 3ft Model
		3322901P	Work Surface, 4ft Model
		3322902P	Work Surface, 5ft Model
		3322903P	Work Surface, 6ft Model
		3322901P	Work Surface, 8ft Model (qty 2 required)
4		3271100	Air Foil Grille, 3ft Model
		3271101	Air Foil Grille, 4ft Model
		3271102	Air Foil Grille, 5ft Model
		3271103	Air Foil Grille, 6ft (A2 & C1 Models)
		3271105	Air Foil Grille, 6ft (B2 Models)
		3271104	Air Foil Grille, 8ft Model
5		3269100	Towel Catch, 3ft Model
		3269101	Towel Catch, 4ft Model
		3269102	Towel Catch, 5ft Model
		3269103	Towel Catch, 6ft Model
6		3269104	Towel Catch, 8ft Model (qty 2 required)
		3210100	Replacement Display PCB, A2
		3210101	Replacement Display PCB, B2
7		3210102	Replacement Display PCB, C1
		3329700	Speaker
8		1233000	Outlet Receptacle, 115v, GFCI (US)
		1232800	Outlet Receptacle, 115v (US)
		1283900	Outlet Receptacle, 230v (US)
		1296600	Outlet Receptacle, 230v (China/Australia)
		1296200	Outlet Receptacle, 230v (UK)
		1296300	Outlet Receptacle, 230v (Schuko)
		1296400	Outlet Receptacle, 230v (India)
9a		3271700	USB Port
9b		3272700	USB Port Cover
10		22-5	3330000
11	1295510		UV Ballast
12	3340000		Remote Communications Board
13	1289200		Relay, SPST
13	1289100		Relay, DPST (For 230v Models Only)
14	5053703		Power Supply Board

Figure 22-4

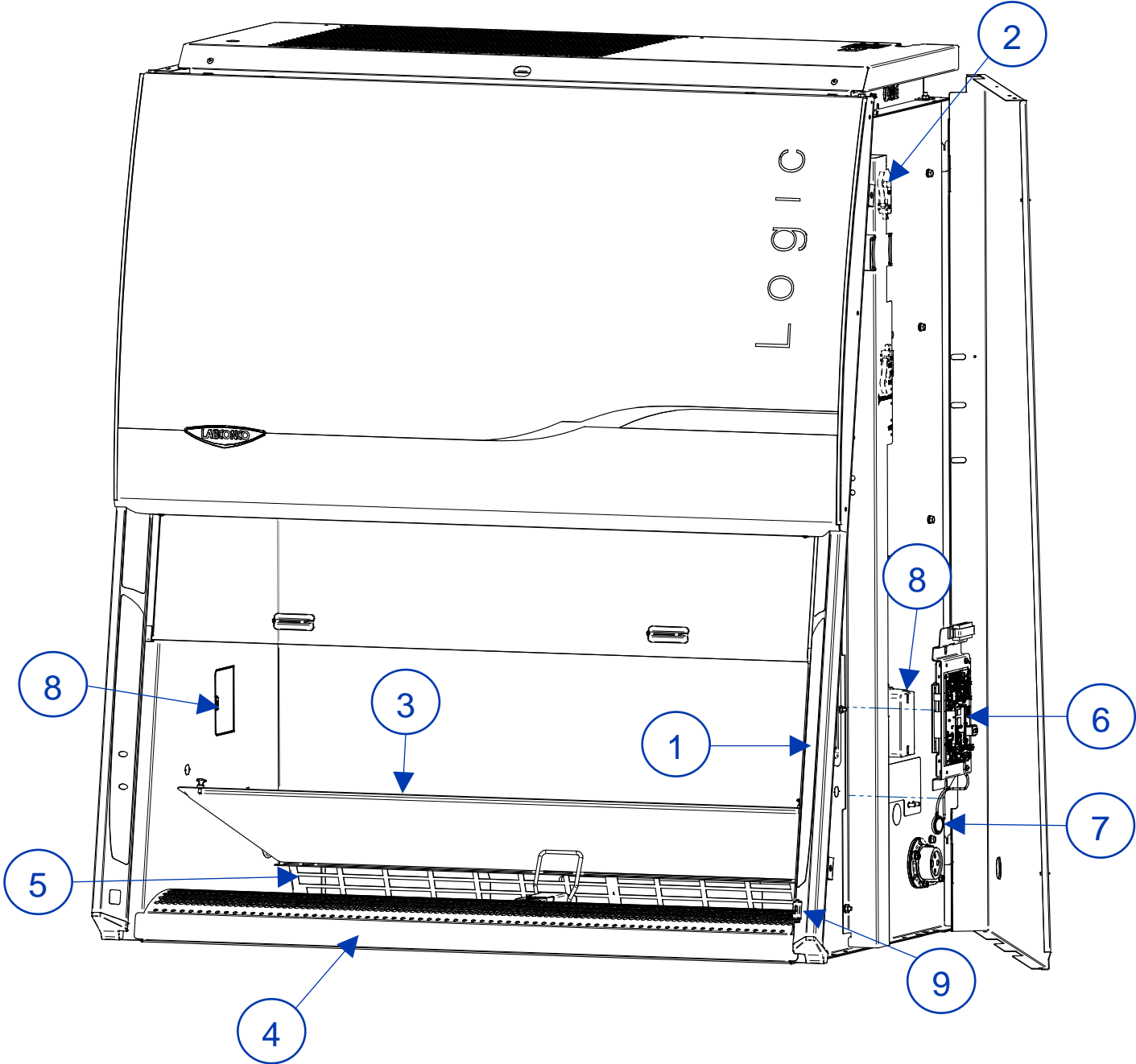


Figure 22-5

