

STAINLESS STEEL  
**GARMENT RACKS**

**Item #:** \_\_\_\_\_ **Qty #:** \_\_\_\_\_

**Model #:** \_\_\_\_\_

**Project #:** \_\_\_\_\_



**Floor Mounted  
FGR**



**Wall Mounted  
WGR**

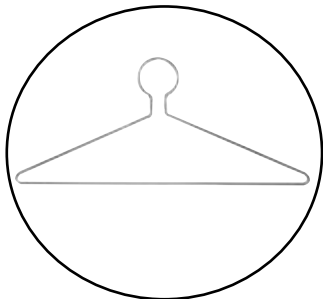

**Stainless Steel  
Hangers**

**FLOOR MOUNTED**

Length	MODEL #	Weight
4'	<b>FGR-4</b>	39 lbs.
5'	<b>FGR-5</b>	48 lbs.
6'	<b>FGR-6</b>	58 lbs.
8'	<b>FGR-8</b>	77 lbs.

**WALL MOUNTED**

Length	MODEL #	Weight
4'	<b>WGR-4</b>	35 lbs.
5'	<b>WGR-5</b>	38 lbs.
6'	<b>WGR-6</b>	46 lbs.
8'	<b>WGR-8</b>	61 lbs.

**ACCESSORIES**

	MODEL #	Qty
S/S Hangers	<b>GH-12</b>	
S/S Flange Feet	<b>BA-11</b>	

**FEATURES:**

**FLOOR MOUNTED:** Constructed from tubular stainless steel. Cross bracing provides stability with the use of elbow brackets. Hanger bar is scored in 2" increments for hanger placement. Assembly required.

**WALL MOUNTED:** Constructed from tubular stainless steel. Tubular shelf provides extra storage space. Hanger bar is scored in 2" increments for hanger placement. Stainless steel wall flanges mount unit to wall. Ideal for clearing up floor space. Assembly required.

Both styles include 12 hangers as standard.

**CONSTRUCTION:**

All tubular parts are die formed on specified radii. Welded areas blended to match adjacent surfaces and to a #4 finish.

**MATERIAL:**

1 5/8" tubular 16 gauge type "304" stainless steel.

16 gauge type "304" stainless steel wall flanges.

Hangers: Close looped stainless steel electropolished hangers.

# DETAILS and SPECIFICATIONS

All Dimensions are Typical (tol.  $\pm$  .500")

All Units Shipped Unassembled (KD) for Reduced Shipping Costs.

## FLOOR MOUNTED

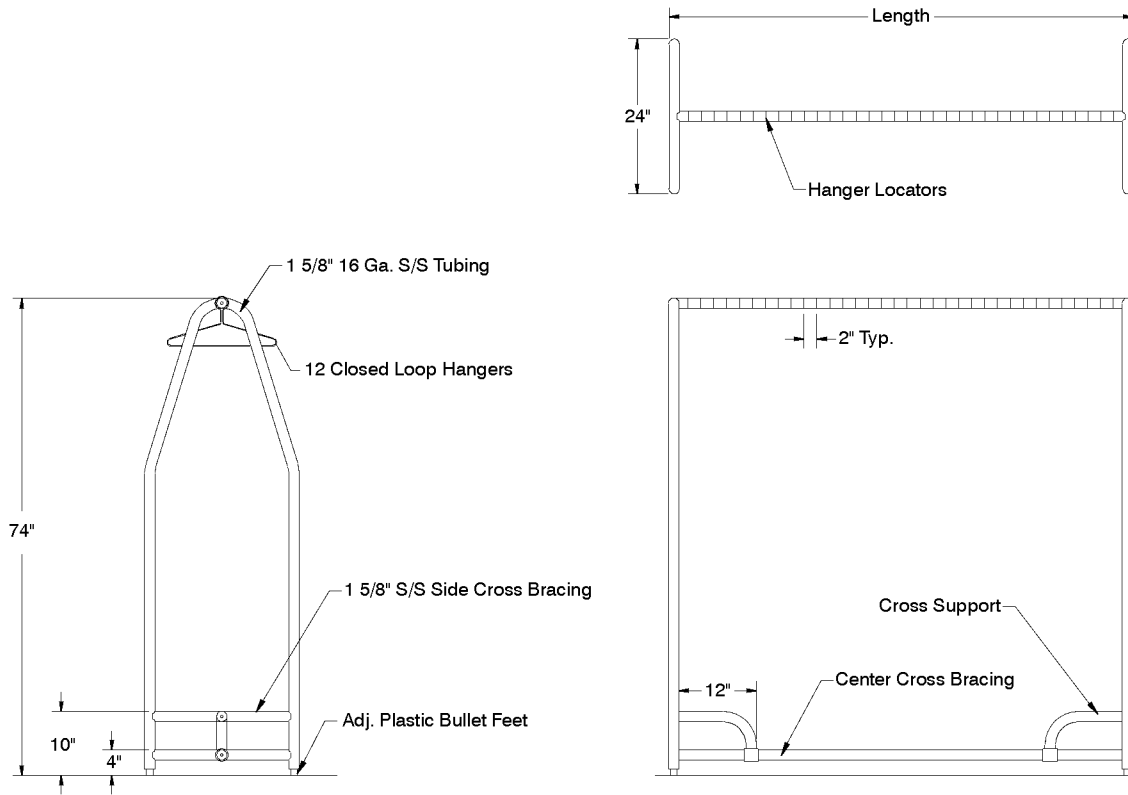

## WALL MOUNTED

